

ON 9MG

L K HOIST

NO	DESCRIPTION	SIZE	MAT' L	Q' TY	WT (kg)	REMARKS

전자식 과부하 장치
(LOAD CELL)

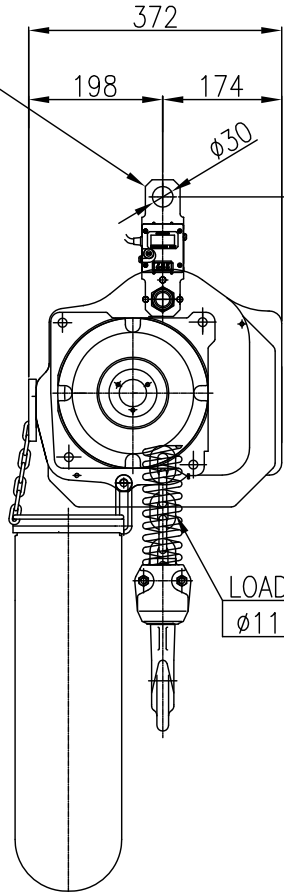

LOAD CHAIN
Ø11.2X34

H min. 738±30

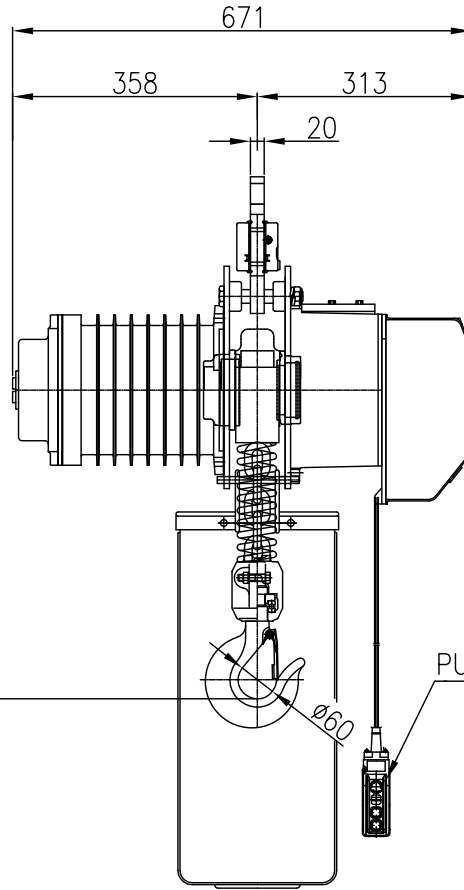

PUSH BUTTON S/W

SPECIFICATION		
RATED LOAD	2	TON
TESTING LOAD	2.5	TON
LIFTING HEIGHT	50	M
HOISTING	SPEED	0.65~6.5 M/MIN (인버터)
	MOTOR	3.5 KW x 1 SET
TRAVERSING	SPEED	- M/MIN
	MOTOR	-
POWER SUPPLY	AC220,380,440,460,480Vx3øx 60Hz	
OPERATING METHOD	P.B type ON . FL	
WIEGHT	252 kg	

TITLE				PROJECTION	
ELECTRIC CHAIN HOIST LK-SSEDA-2S					
WORK NO	WORK NAME			SCALE	Q' TY
				1/1	1
DRAWN	CHECKED	REVIEWED	APPROVED	DRAWING NO	
KIM CH KI					
2018.09.05					



L K HOIST CO., LTD.