

L K HOIST

ON 9MD

NO	DESCRIPTION	SIZE	MAT' L	Q' TY	WT (kg)	REMARKS

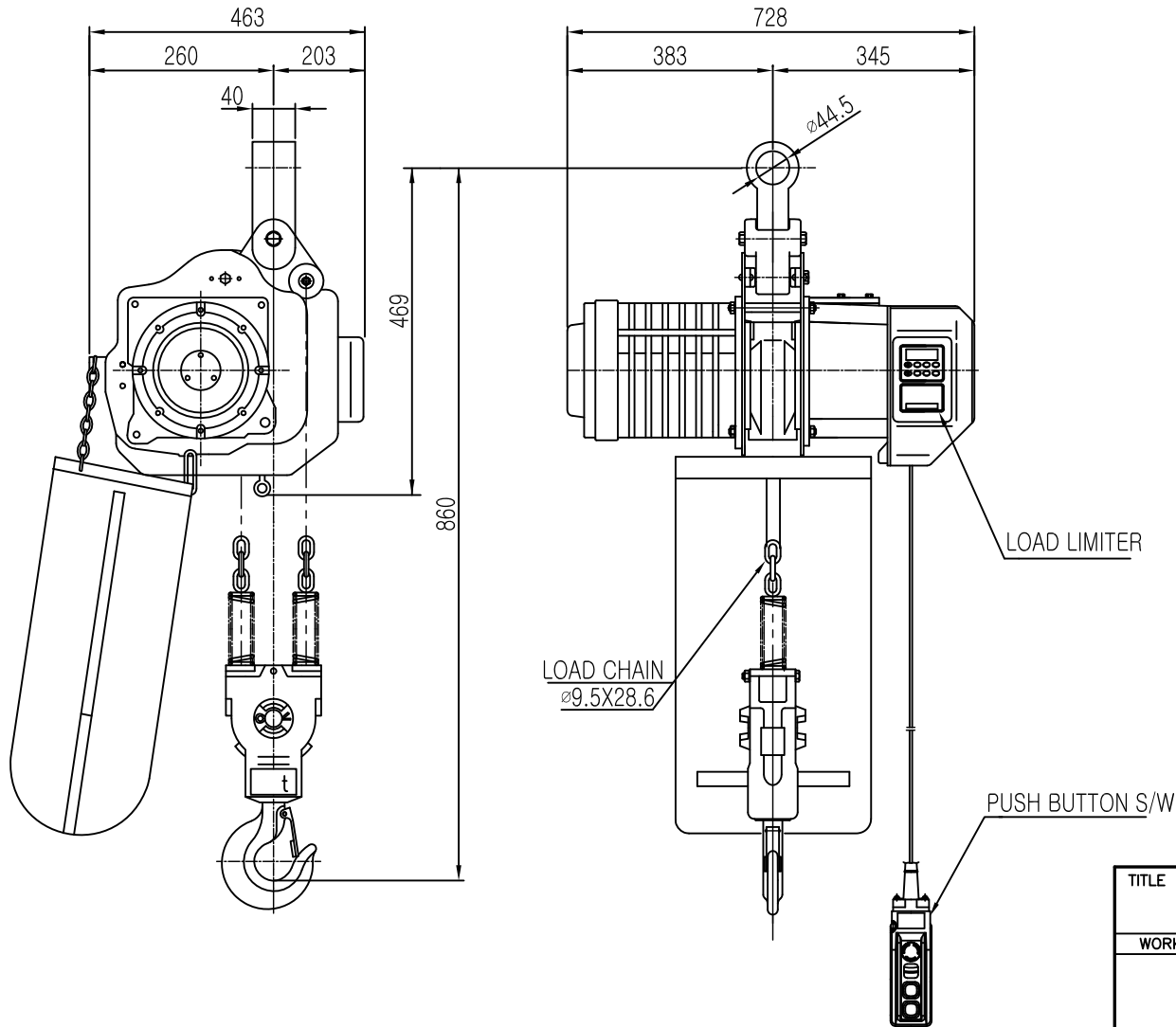

SPECIFICATION	
HOISTING LOAD	3.0 TON
TESTING LOAD	3.75 TON
LIFTING HEIGHT	50 M
HOISTING	SPEED 5.15/1.7 M/MIN
	MOTOR 4.4/2.2 KW x 2/6P
TRAVERSING	SPEED - M/MIN
	MOTOR - KW x - SET
POWER SUPPLY	AC220,380,440,460,480V x 3 ϕ x 60 Hz
OPERATING METHOD	P.B type ON . FL
LOAD CHAIN	$\phi 9.5 \times 28.6$ (2 FALL)
WIEGHT	330 KG

NOTE)

- 1) 점검 설비를 갖출것.
- 2) 인허가 서류를 완성검사시 제출할것.

REV.NO	DATE	REVISION	DESCRIPTION	DRAWN	CHECKED	APPROVED

TITLE					PROJECTION	
DB-3W ELECTRIC CHAIN HOIST						
WORK NO	WORK NAME				SCALE	Q' TY
	CONNECTOR TYPE				N S	1
DRAWN	CHECKED	REVIEWED	APPROVED	DRAWING NO		
김 창 기						
2010.07.27						

L K HOIST

ON 9MD

NO	DESCRIPTION	SIZE	MAT' L	Q' TY	WT (kg)	REMARKS

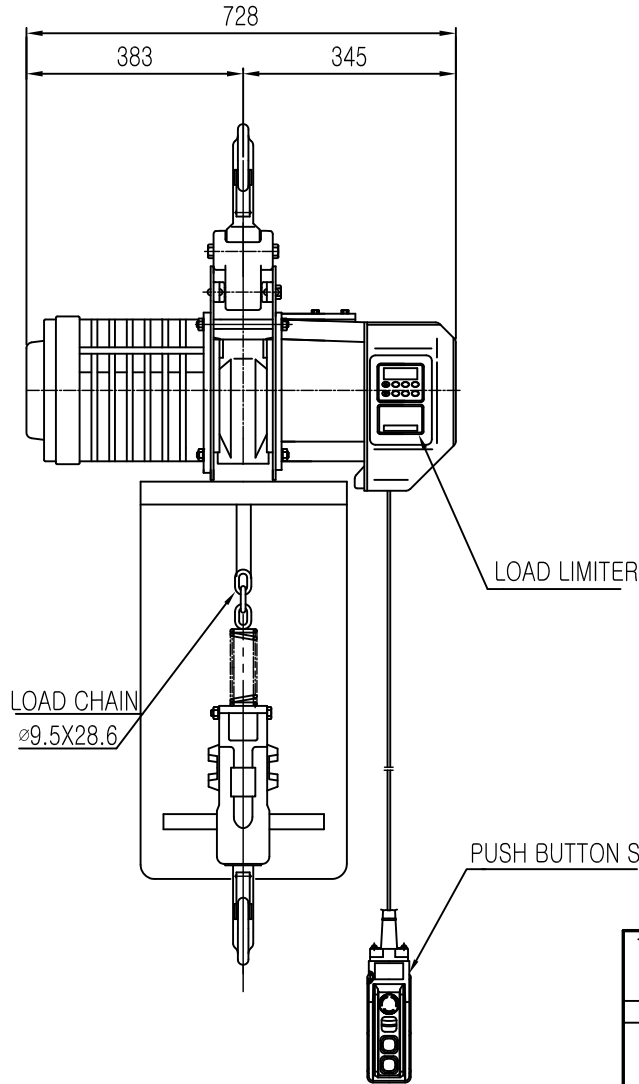
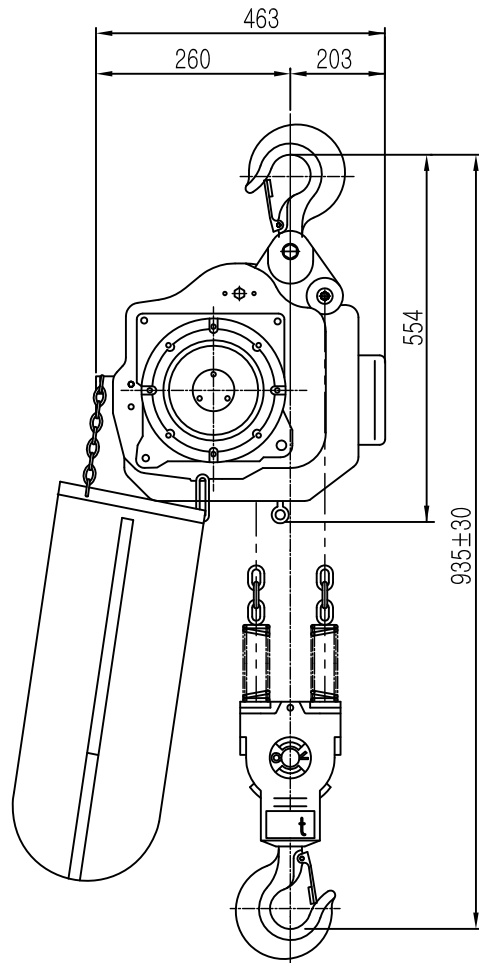

SPECIFICATION		
HOISTING LOAD	3.0 TON	
TESTING LOAD	3.75 TON	
LIFTING HEIGHT	50 M	
HOISTING	SPEED	5.15/1.7 M/MIN
	MOTOR	4.4/2.2 KW x 2/6P
TRAVERSING	SPEED	- M/MIN
	MOTOR	- KW x - SET
POWER SUPPLY	AC220,380,440,460,480V x 3ø x 60 Hz	
OPERATING METHOD	P.B type ON . FL	
LOAD CHAIN	ø9.5 x 28.6 (2 FALL)	
WIEGHT	330 KG	

NOTE)

- 1) 점검 설비를 갖출것.
- 2) 인허가 서류를 완성검사시 제출할것.

TITLE					PROJECTION	
DB-3W ELECTRIC CHAIN HOIST						
WORK NO	WORK NAME				SCALE	Q' TY
	HOOK TYPE				N S	1
DRAWN	CHECKED	REVIEWED	APPROVED	DRAWING NO		
김 창 기						
2010.07.27						

REV.NO	DATE	REVISION	DESCRIPTION	DRAWN	CHECKED	APPROVED

ON 3MD

L K HOIST

NO	DESCRIPTION	SIZE	MAT L	Q' TY	WT (kg)	REMARKS

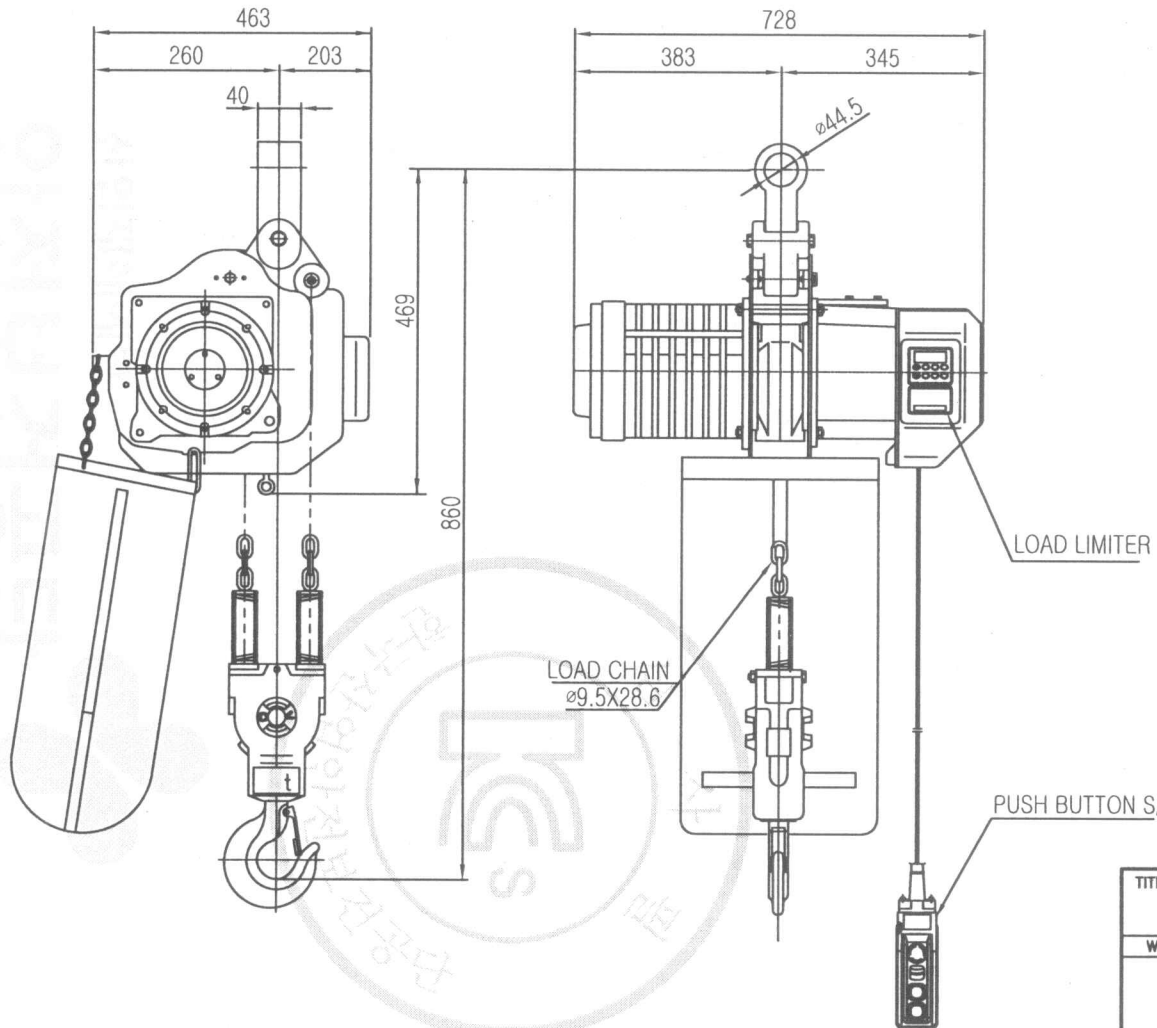

SPECIFICATION		
HOISTING LOAD	3.0	TON
TESTING LOAD	3.75	TON
LIFTING HEIGHT	50	M
HOISTING	SPEED	5.15/1.7 M/MIN
	MOTOR	4.4/2.2KW x 2/6P
TRAVERSING	SPEED	- M/MIN
	MOTOR	- KW x - SET
POWER SUPPLY	AC220,380,440,460,480V x 3ø x 60 Hz	
OPERATING METHOD	P.B type ON . FL	
LOAD CHAIN	ø9.5 x 28.6 (2 FALL)	
WIEGHT	330 KG	

NOTE)

- 1) 점검 설비를 갖출것.
- 2) 인허가 서류를 완성검사시 제출할것.

TITLE					PROJECTION	
DB-3W ELECTRIC CHAIN HOIST						
WORK NO	WORK NAME					
CONNECTOR TYPE					SCALE	Q' TY
					N	S 1
DRAWN	CHECKED	REVIEWED	APPROVED	DRAWING NO		
김창기						
2010.07.27						
L K HOIST CO., LTD.						

REV.NO	DATE	REVISION	DESCRIPTION	DRAWN	CHECKED	APPROVED

물범복제 및 배포금지

ON ㄱMG

L K HOIST

NO	DESCRIPTION	SIZE	MAT'L	Q'TY	WT (kg)	REMARKS

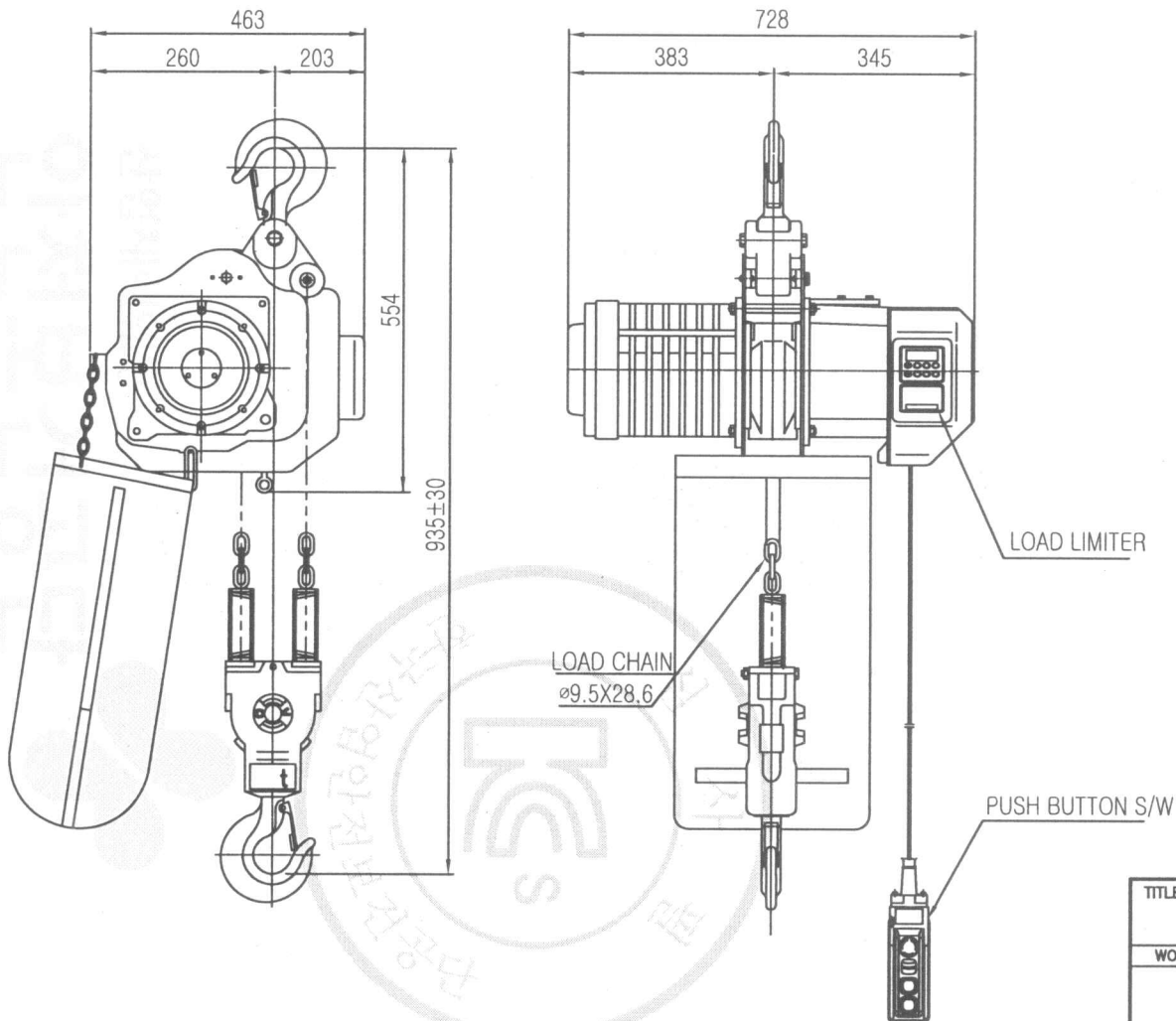

SPECIFICATION		
HOISTING LOAD	3.0	TON
TESTING LOAD	3.75	TON
LIFTING HEIGHT	50	M
HOISTING	SPEED	5.15/1.7 M/MIN
	MOTOR	4.4/2.2 KW x 2/6P
TRAVERSING	SPEED	- M/MIN
	MOTOR	- KW x - SET
POWER SUPPLY	AC220,380,440,460,480V x 3φ x 60 Hz	
OPERATING METHOD	P.B type ON . FL	
LOAD CHAIN	φ9.5 x 28.6 (2 FALL)	
WIEGHT	330 KG	

NOTE)

- 1) 점검 설비를 갖출것.
- 2) 인허가 서류를 완성검사시 제출할것.

TITLE				PROJECTION	
DB-3W ELECTRIC CHAIN HOIST					
WORK NO	WORK NAME			SCALE	Q'TY
	HOOK TYPE			N	S 1
DRAWN	CHECKED	REVIEWED	APPROVED	DRAWING NO	
김 창 기					
2010.07.27					
L K HOIST CO., LTD.					

REV.NO	DATE	REVISION	DESCRIPTION	DRAWN	CHECKED	APPROVED

물품복제 및 배포금지