

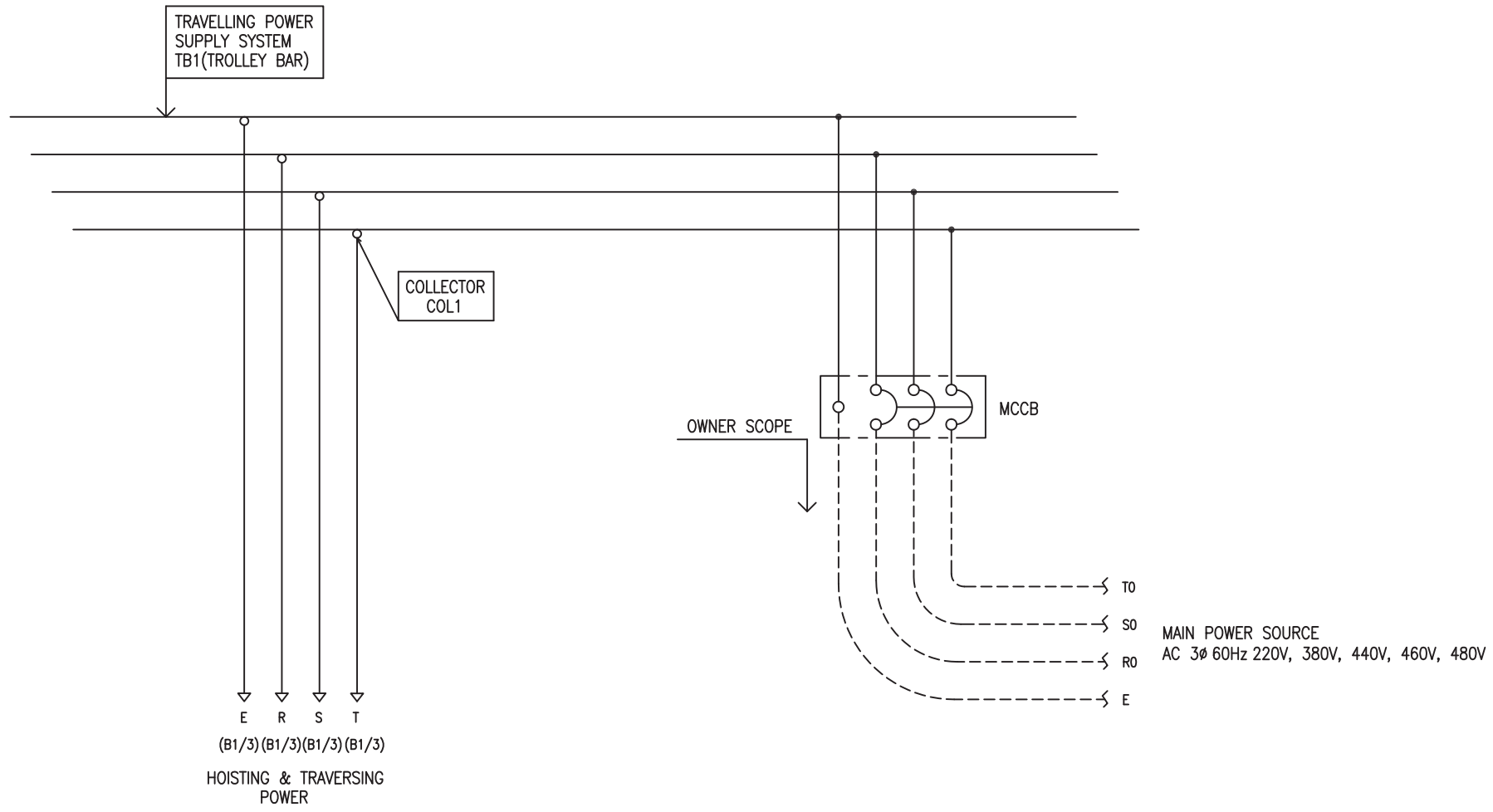

POWER CIRCUIT
TRAVELLING POWER SUPPLY SYSTEM

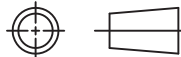

- NOTE-
1. - - - - MARKED OWNER SCOPE
 2. ——— MARKED CRANE MAKER SCOPE

TITLE MAIN POWER CIRCUIT DIAGRAM1				PROJECTION 	
WORK NO	WORK NAME			SCALE	Q' TY
601	DBM 220V, 380V, 440V, 460V, 480V			1/1	1
DRAWN	CHECKED	REVIEWED	APPROVED	DRAWING NO	DBM
LEE G.H.				CODE NO	
2010.07.30					
 L K HOIST CO., LTD.					



-NOTE-

1. ----- MARKER OWNER SCOPE
2. 24V인 경우 F21는 3A 적용

HOISTING & TRAVERSING POWER

SPECIFICATION	NO FUSE BREAKER	MAGNET CONTACT	TRANSFORMER	FUZE	
SYMBOLS	MCCB0	MO	TR10	F11, F12, F21	
DESCRIPTION	220V	30A	GMC22	DMC22	
	380V	20A			
	440V	20A			
	460V	20A			
	480V	15A			
MAKER	LS	LS	DONGA	LK	-

TITLE MAIN POWER & CONTROL CIRCUIT DIAGRAM						PROJECTION	
WORK NO 602		WORK NAME DBM				SCALE 1/1	Q' TY 1
DRAWN LEE.G.H	CHECKED	REVIEWED	APPROVED	MODEL	DBM		
2010.07.30				CODE NO			
L K HOIST CO., LTD.							

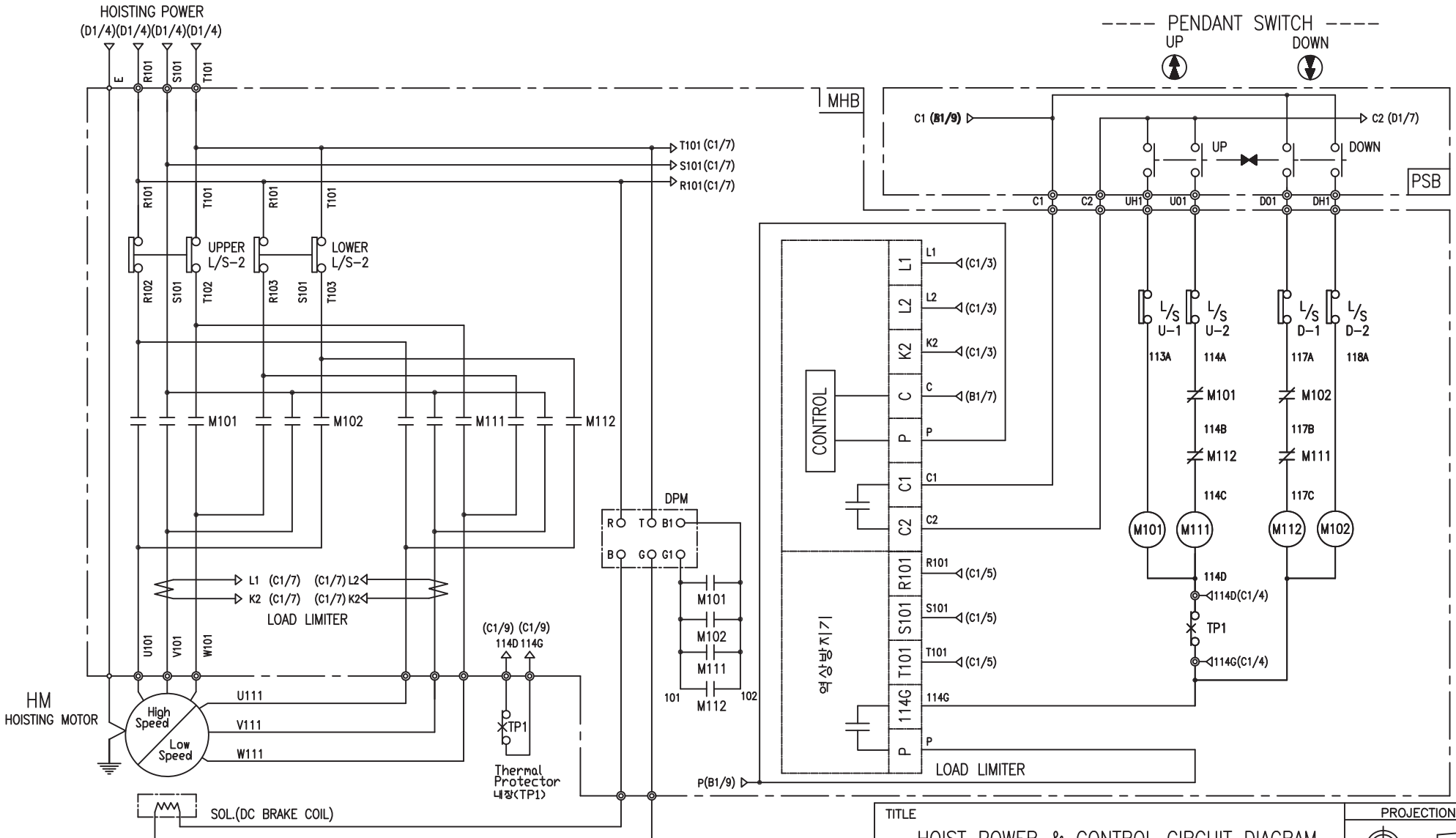

-NOTE-
1. : Mechanical Interlock

SPECIFICATION	MAGNET CONTACT	LOAD LIMITER	SILICON RECTIFIER				Thermal Protector	HOIST MOTOR
SYMBOLS	M101, M102	-	DPM				TP1	HM
	M103, M104		AC380V	AC440V	AC460V	AC480V		
DESCRIPTION	DMC12	LKDL-601	DC171V	DC198V	DC207V	DC216V	17AM032	1.8Kw * 2P/0.7Kw*6P
MAKER	DONG-A	LK	LK				Texas Instruments	LK

TITLE HOIST POWER & CONTROL CIRCUIT DIAGRAM						PROJECTION 	
WORK NO 604		WORK NAME DBM				SCALE 1/1	
DRAWN LEE.G.H		CHECKED		REVIEWED		APPROVED	
2010.07.30		MODEL DBM		CODE NO			
L K HOIST CO., LTD.							

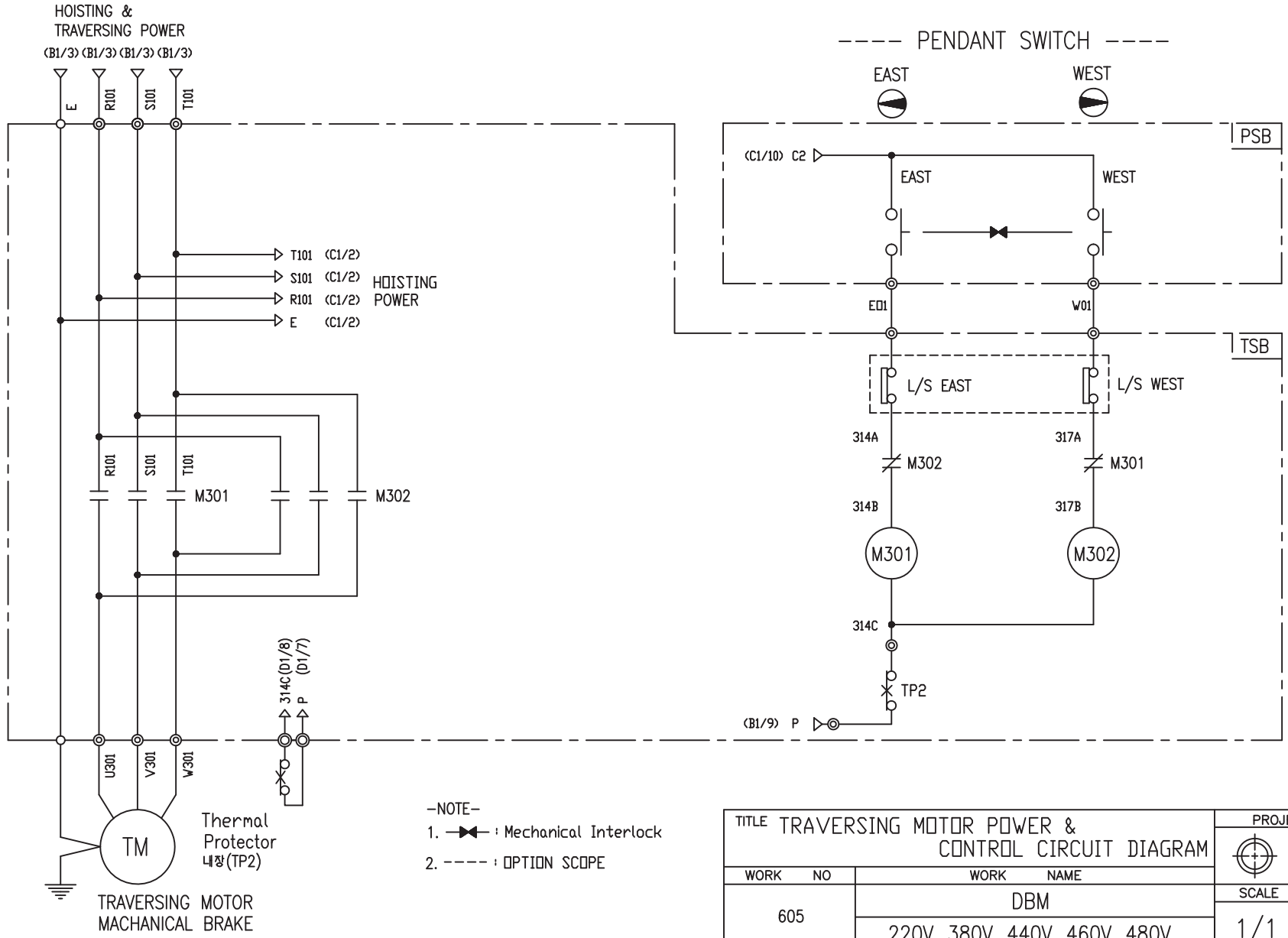

-NOTE-
 1. ——— : Mechanical Interlock
 2. - - - - : OPTION SCOPE

TITLE TRAVERSING MOTOR POWER & CONTROL CIRCUIT DIAGRAM						PROJECTION	
WORK NO. 605						WORK NAME DBM	
220V, 380V, 440V, 460V, 480V						SCALE 1/1	Q' TY 1
DRAWN LEE.G.H	CHECKED	REVIEWED	APPROVED	MODEL	DBM		
2010.07.30				CODE NO			
L K HOIST CO., LTD.							

SPECIFICATION	MAGNET CONTACT		Thermal Protector	TRAVERSING MOTOR	
SYMBOLS	M301, M302		TP2	TM	
DESCRIPTION	GMC12	DMC12	17AM032	0.4KW *4P	0.3KW *6P
MAKER	LS	DONGA	Texas Instruments	LK	

SCHEDULE OF TECHNICAL DATA

1. SERVICE	HOISTING
2. MANUFACTURE	LK HOIST CO. LTD
3. MOTOR MODEL NO	1.8/0.7 - 2/6 - 38
4. RATED POWER	1.8/0.7 KW × 2/6 P
5. RATED VOLTAGE AND FREQUENCY	380 V 60HZ
6. MOTOR TYPE	SQUIRREL CAGE ROTOR TYPE
7. RATING	30 MIN
8. LOCATION	IN-DOOR , OUTDOOR
9. INSULATION CLASS	B
10. DESIGN TEMPERATURE RISE (BY RESISTANCE)	80℃
11. FULL LOAD SPEED	3440/1140 RPM
12. FULL LOAD CURRENT	6.8/2.7 A
13. STARTING CURRENT AT RATED VOLTAGE	35.3/14 A
14. MINIMUM STARTING VOLTAGE	342 V
15. EFFICIENCY AT 100% RATED LOAD	64/64 %
16. POWER FACTOR AT 100% RATED LOAD	64/64 %
17. STARTING TORQUE	235 %
18. TYPE OF ENCLOSURE	전폐형
19. TYPE OF BEARING	PL : 6205DD OPL : 6008ZZ
20. MOUNTING	VERTICAL
21. MAXIMUM AMBIENT TEMPURE	40℃
22. BEARING LUBRICATION	GREASE
23. STARTING METHOD	FULL VOLTAGE

SCHEDULE OF TECHNICAL DATA

1. SERVICE	TRAVERSING
2. MANUFACTURE	LK HOIST CO. LTD
3. MOTOR MODEL NO	0.4 - 4 - 38
4. RATED POWER	0.4 KW × 4 P
5. RATED VOLTAGE AND FREQUENCY	380 V 60HZ
6. ROTOR TYPE	SQUIRREL CAGE ROTOR TYPE
7. RATING	15 MIN
8. LOCATION	IN-DOOR , OUTDOOR
9. INSULATION CLASS	B
10. DESIGN TEMPERATURE RISE (BY RESISTANCE)	100℃
11. FULL LOAD SPEED	1710 RPM
12. FULL LOAD CURRENT	1.8 A
13. STARTING CURRENT AT RATED VOLTAGE	8.28 A
14. MINIMUM STARTING VOLTAGE	343 V
15. EFFICIENCY AT 100% RATED LOAD	59 %
16. POWER FACTOR AT 100% RATED LOAD	67.2 %
17. STARTING TORQUE	232 %
18. TYPE OF ENCLOSURE	전폐형
19. TYPE OF BEARING	PL : 6202DD OPL : 6004ZZ
20. MOUNTING	VERTICAL
21. MAXIMUM AMBIENT TEMPERATURE	40℃
22. BEARING LUBRICATION	GREASE
23. STARTING METHOD	FULL VOLTAGE

SCHEDULE OF TECHNICAL DATA

1. SERVICE	TRAVERSING
2. MANUFACTURE	LK HOIST CO. LTD
3. MOTOR MODEL NO	0.3 - 6 - 38
4. RATED POWER	0.3 KW × 6 P
5. RATED VOLTAGE AND FREQUENCY	380 V 60HZ
6. ROTOR TYPE	SQUIRREL CAGE ROTOR TYPE
7. RATING	15 MIN
8. LOCATION	IN-DOOR , OUTDOOR
9. INSULATION CLASS	B
10. DESIGN TEMPERATURE RISE (BY RESISTANCE)	100℃
11. FULL LOAD SPEED	1140 RPM
12. FULL LOAD CURRENT	1.7 A
13. STARTING CURRENT AT RATED VOLTAGE	9.3 A
14. MINIMUM STARTING VOLTAGE	342 V
15. EFFICIENCY AT 100% RATED LOAD	53 %
16. POWER FACTOR AT 100% RATED LOAD	51 %
17. STARTING TORQUE	249 %
18. TYPE OF ENCLOSURE	전폐형
19. TYPE OF BEARING	PL : 6008DD OPL : 6207ZZ
20. MOUNTING	VERTICAL
21. MAXIMUM AMBIENT TEMPERATURE	40℃
22. BEARING LUBRICATION	GREASE
23. STARTING METHOD	FULL VOLTAGE

SCHEDULE OF TECHNICAL DATA

1. SERVICE	TRAVERSING
2. MANUFACTURE	LK HOIST CO. LTD
3. MOTOR MODEL NO	0.4/0.14 - 4/12 - 38
4. RATED POWER	0.4/0.14 KW × 4/12 P
5. RATED VOLTAGE AND FREQUENCY	380 V 60HZ
6. MOTOR TYPE	SQUIRREL CAGE ROTOR TYPE
7. RATING	15 MIN
8. LOCATION	IN-DOOR , OUTDOOR
9. INSULATION CLASS	B
10. DESIGN TEMPERATURE RISE (BY RESISTANCE)	100℃
11. FULL LOAD SPEED	1710 / 550 RPM
12. FULL LOAD CURRENT	1.8 / 1.1 A
13. STARTING CURRENT AT RATED VOLTAGE	8.96 / 5.47 A
14. MINIMUM STARTING VOLTAGE	343 V
15. EFFICIENCY AT 100% RATED LOAD	59 / 47.3 %
16. POWER FACTOR AT 100% RATED LOAD	67.2 / 42.3 %
17. STARTING TORQUE	232/ 234 %
18. TYPE OF ENCLOSURE	전폐형
19. TYPE OF BEARING	PL : 6008DD OPL : 6207ZZ
20. MOUNTING	VERTICAL
21. MAXIMUM AMBIENT TEMPURE	40℃
22. BEARING LUBRICATION	GREASE
23. STARTING METHOD	FULL VOLTAGE