

POWER CIRCUIT

ADDRESS NO.

TRAVELLING POWER SUPPLY SYSTEM

A1

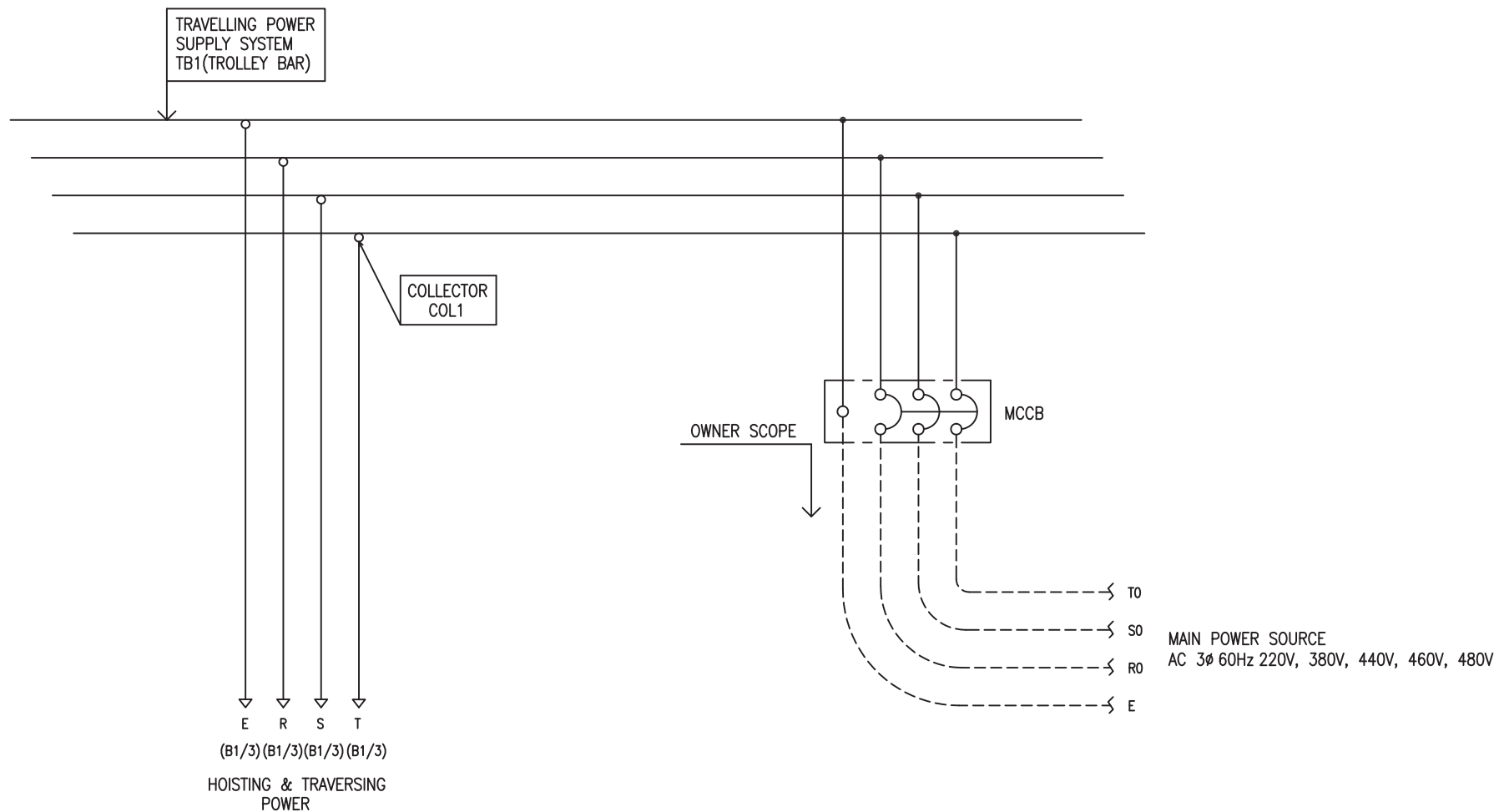

-NOTE-

1. - - - - MARKED OWNER SCOPE
2. ——— MARKED CRANE MAKER SCOPE

TITLE				PROJECTION	
MAIN POWER CIRCUIT DIAGRAM1					
WORK NO	WORK NAME			SCALE	Q' TY
601	DHDBM			1/1	1
220V, 380V, 440V, 460V, 480V					
DRAWN	CHECKED	REVIEWED	APPROVED	DRAWING NO	DHDBM
LEE G.H.				CODE NO	
2010.07.30					
L K HOIST CO., LTD.					



-NOTE-

1. ----- MARKER OWNER SCOPE
2. 24V인 경우 F21는 3A 적용

SPECIFICATION	NO FUSE BREAKER	MAGNET CONTACT	TRANSFORMER	FUZE		
SYMBOLS	MCCB0	MO	TR10	F11, F12, F21		
DESCRIPTION	220V	30A	GMC22	DMC22	30VA	1A
	380V	20A				
	440V	20A				
	460V	20A				
480V	15A					
MAKER	LS	LS	DONGA	LK	-	

TITLE MAIN POWER & CONTROL CIRCUIT DIAGRAM						PROJECTION	
WORK NO 602		WORK NAME DHDBM				SCALE 1/1	
220V, 380V, 440V, 460V, 480V		DRAWN LEE.G.H		CHECKED	REVIEWED	APPROVED	MODEL DHDBM
2010.07.30		CODE NO					
L K HOIST CO., LTD.							

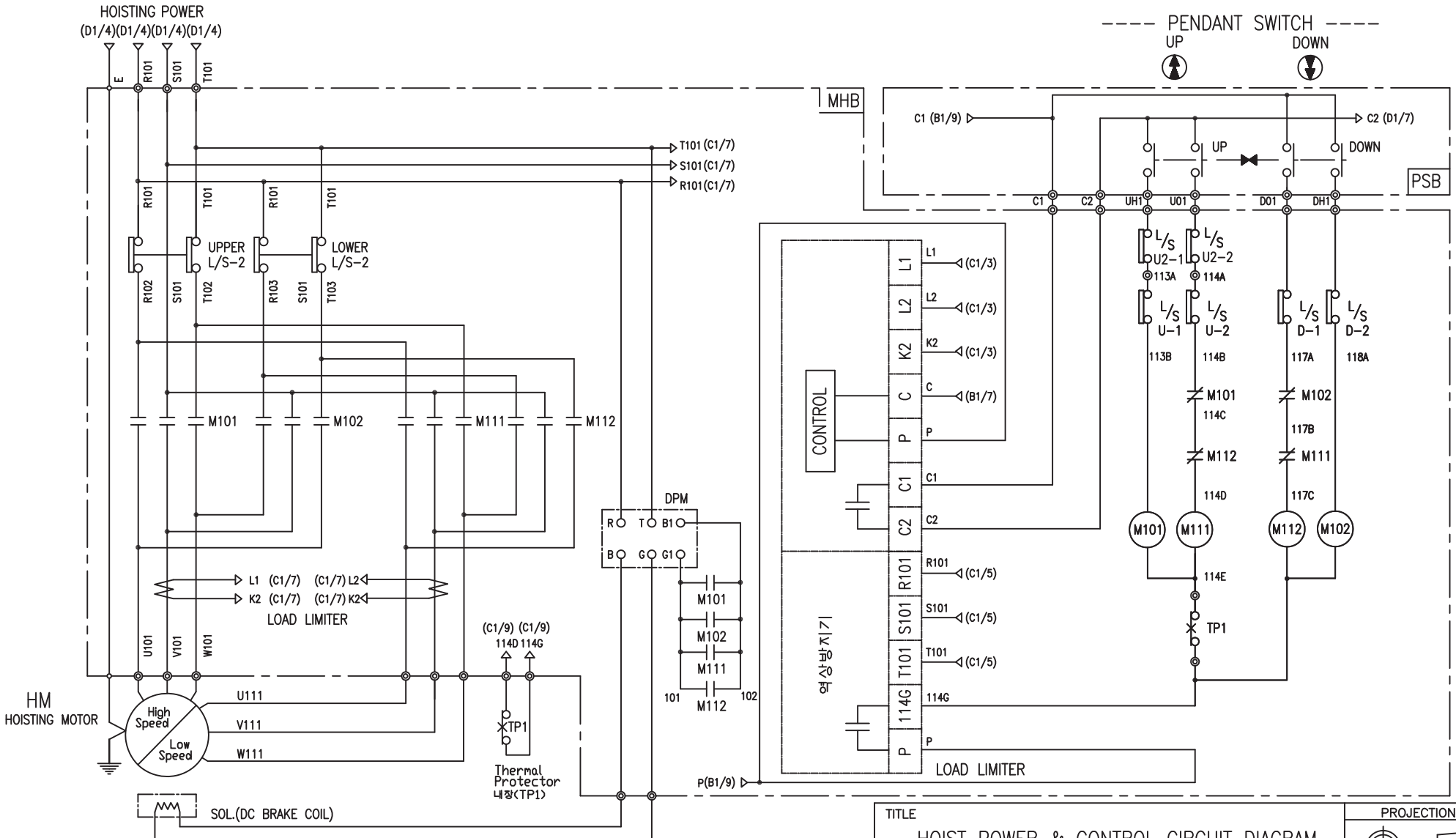

-NOTE-
 1. : Mechanical Interlock

SPECIFICATION	MAGNET CONTACT	LOAD LIMITER	SILICON RECTIFIER	Thermal Protector	HOIST MOTOR
SYMBOLS	M101, M102 M103, M104	-	DPM AC220V	TP1	HM
DESCRIPTION	DMC12	LKDL-601	DC99V	17AM032	1.8Kw * 2P/0.7Kw*6P
MAKER	DONG-A	LK	LK	Texas Instruments	LK

TITLE						PROJECTION	
HOIST POWER & CONTROL CIRCUIT DIAGRAM							
WORK NO		WORK NAME				SCALE	
603		DHDBM				1/1	
		220V				Q' TY	
						1	
DRAWN	CHECKED	REVIEWED	APPROVED	MODEL	DHDBM		
LEE.G.H				CODE NO			
2010.07.30							
L K HOIST CO., LTD.							

TRAVERSING POWER CIRCUIT

TRAVERSING CONTROL CIRCUIT

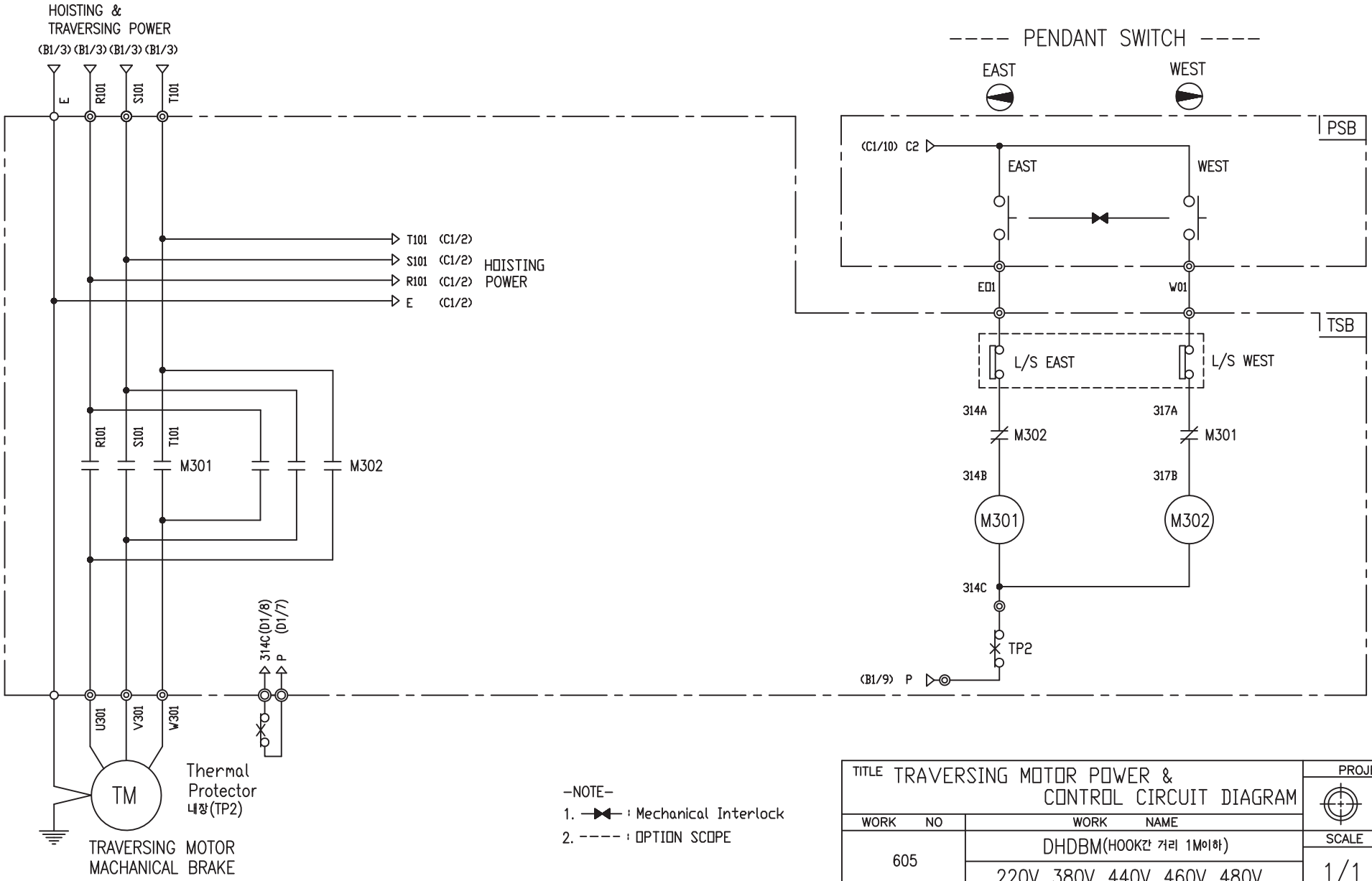

SPECIFICATION	MAGNET CONTACT	Thermal Protector	TRAVERSING MOTOR
SYMBOLS	M301, M302	TP2	TM
DESCRIPTION	GMC12 DMC12	17AM032	0.4KW *4P 0.3KW *6P
MAKER	LS DONGA	Texas Instruments	LK

TITLE TRAVERSING MOTOR POWER & CONTROL CIRCUIT DIAGRAM						PROJECTION	
WORK NO		WORK NAME					
605		DHDBM(HOOK간 거리 1M이하)				SCALE	Q' TY
		220V, 380V, 440V, 460V, 480V				1/1	1
DRAWN	CHECKED	REVIEWED	APPROVED	MODEL	DHDBM		
LEE.G.H				CODE NO			
2010.07.30							
L K HOIST CO., LTD.							

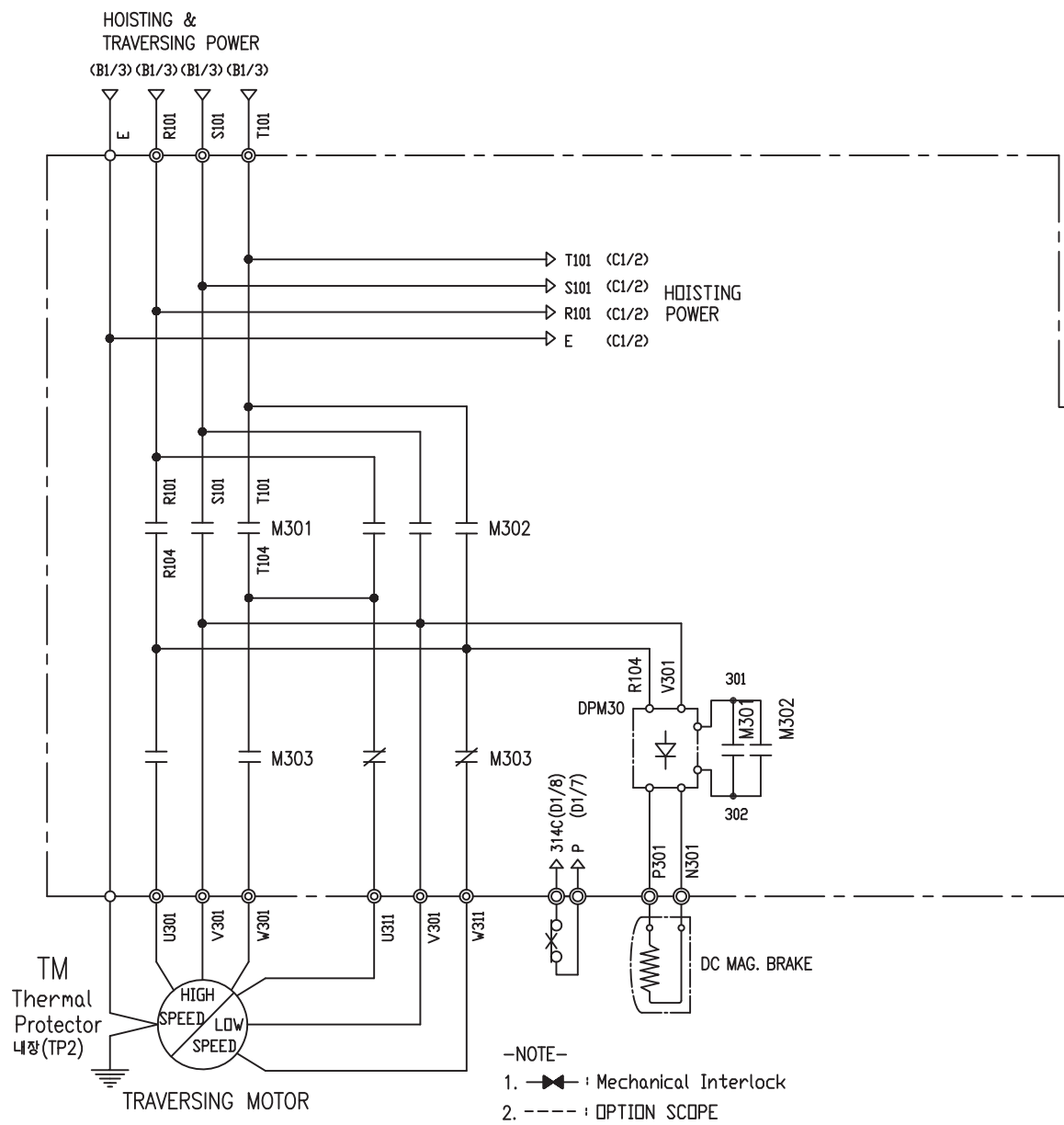

-NOTE-

- ➡ : Mechanical Interlock
- : OPTION SCOPE

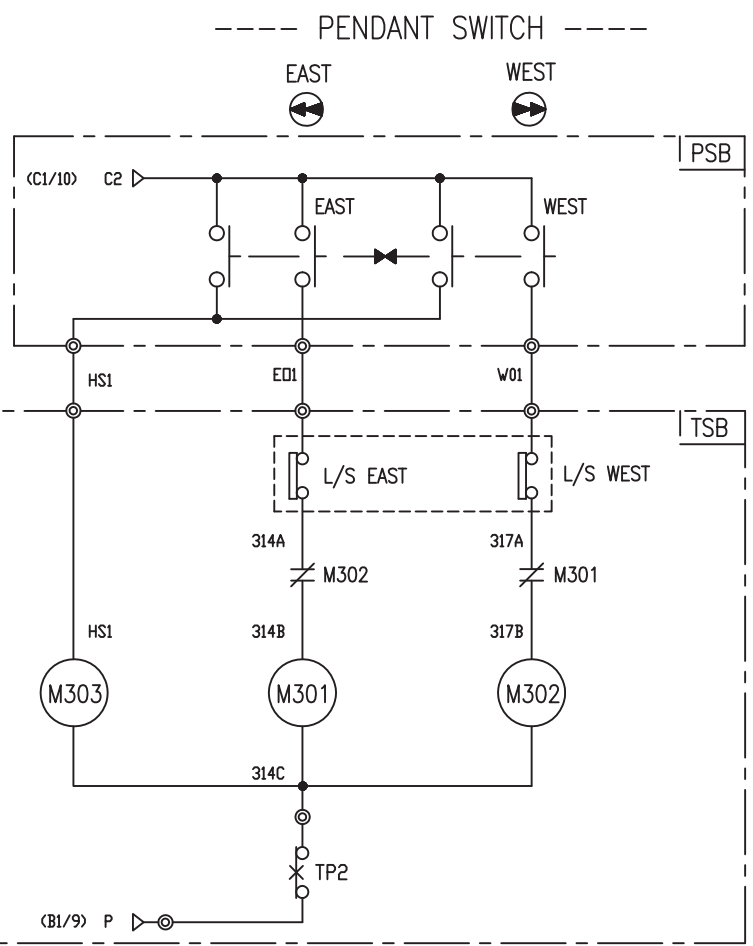

SPECIFICATION	MAGNET CONTACT	Thermal Protector	SILICON RECTIFIER					TRAVERSING MOTOR	
SYMBOLS	M301, M302, M303	TP2	DPM30					TM	
DESCRIPTION	GMC12	DMC12	17AM032	AC220V	AC380V	AC440V	AC460V	AC480V	0.4/0.14KW *4/12P
				DC99V	DC171V	DC198V	DC207V	DC216V	
MAKER	LS	DONGA	Texas Instruments	LK					LK

TITLE TRAVERSING MOTOR POWER & CONTROL CIRCUIT DIAGRAM						PROJECTION			
WORK NO		WORK NAME				SCALE		Q' TY	
606		DHDBM(HOOK간 거리 1M이하)				1/1		1	
220V, 380V, 440V, 460V, 480V		DRAWN		CHECKED	REVIEWED	APPROVED	MODEL		DHDBM
LEE.G.H		2010.07.30		CODE		NO			
L K HOIST CO., LTD.									

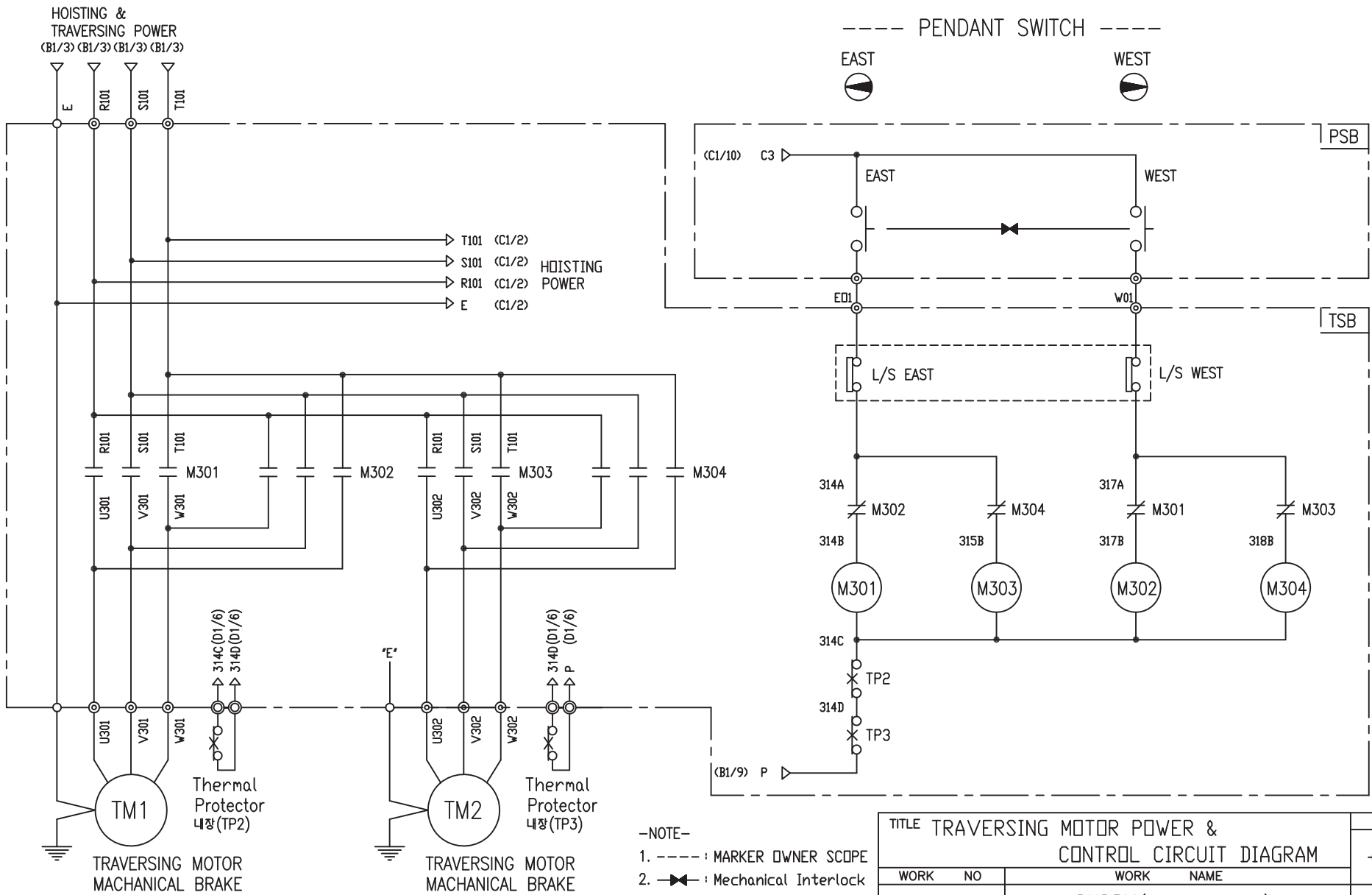

-NOTE-

1. ----- : MARKER OWNER SCOPE

2. ———▶— : Mechanical Interlock

TITLE TRAVERSING MOTOR POWER & CONTROL CIRCUIT DIAGRAM						PROJECTION	
WORK NO		WORK NAME					
607		DHDBM (HOOK간 거리 1M이상)				SCALE	
		220V, 380V, 440V, 460V, 480V				Q' TY	
						1/1	
						1	
DRAWN	CHECKED	REVIEWED	APPROVED	MODEL	DHDAM		
LEE.G.H				CODE NO			
2010.07.30							
L K HOIST CO., LTD.							

SPECIFICATION	MAGNET CONTACT	Thermal Protector	TRAVERSING MOTOR	
SYMBOLS	M301, M302, M303, M304	TP2, TP3	TM1, TM2	
DESCRIPTION	GMC12	DMC12	0.4KW *4P(2set)	0.3KW *6P(2set)
MAKER	LS	DONGA	Texas Instruments	
			LK	

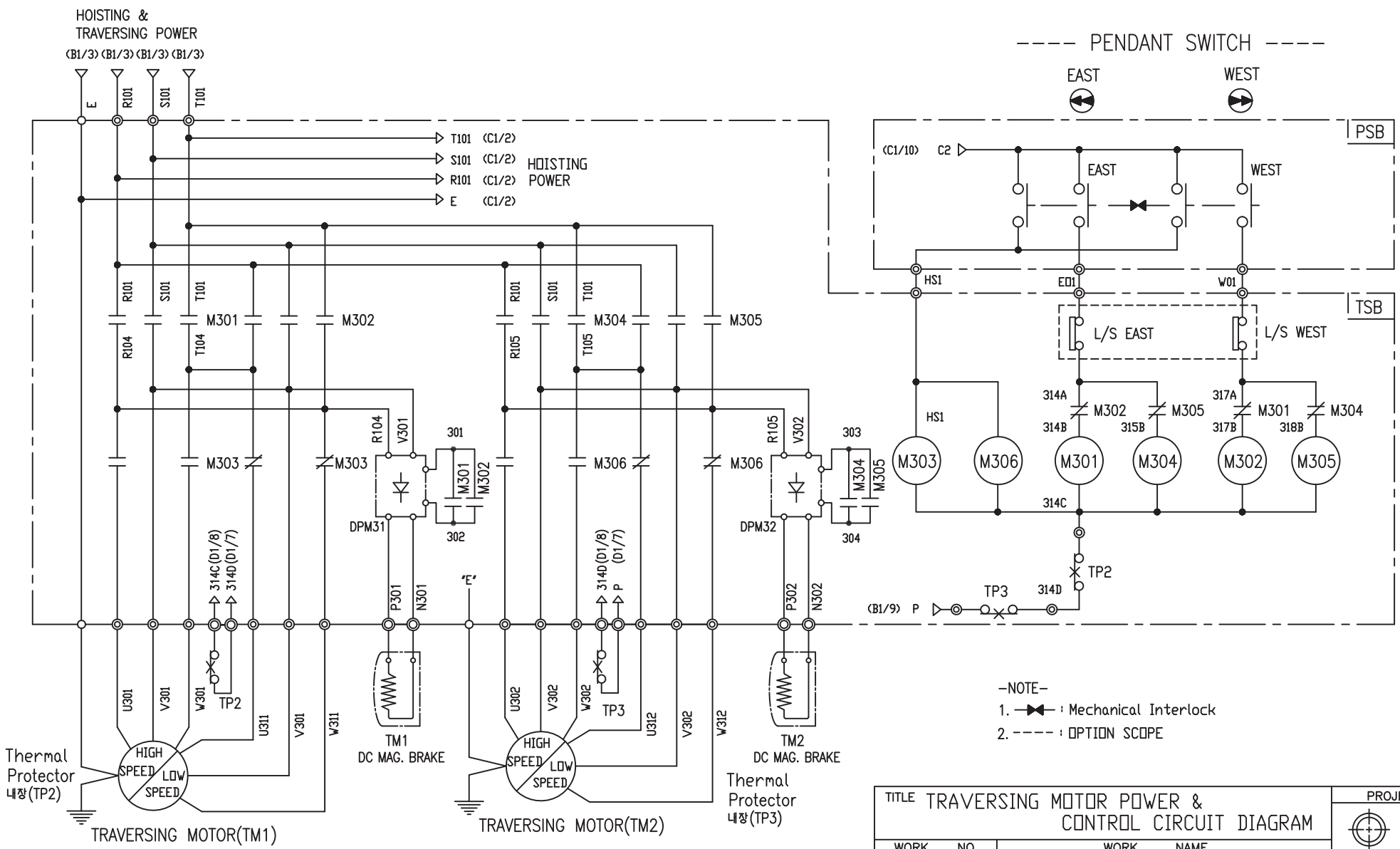

-NOTE-

1. : Mechanical Interlock
2. : OPTION SCOPE

SPECIFICATION	MAGNET CONTACT	Thermal Protector	SILICON RECTIFIER					TRAVERSING MOTOR	
SYMBOLS	M301, M302, M303 M304, M305, M306	TP2, TP3	DPM31, DPM32					TM1, TM2	
DESCRIPTION	GMC12	DMC12	17AM032	AC220V	AC380V	AC440V	AC460V	AC480V	0.4/0.14KW ※4/12P (2set)
				DC99V	DC171V	DC198V	DC207V	DC216V	
MAKER	LS	DONGA	Texas Instruments	LK					LK

TITLE TRAVERSING MOTOR POWER & CONTROL CIRCUIT DIAGRAM						PROJECTION	
WORK NO		WORK NAME					
608		DHDBM (HOOK간 거리 1M이상)				SCALE	Q' TY
		220V, 380V, 440V, 460V, 480V				1/1	1
DRAWN	CHECKED	REVIEWED	APPROVED	MODEL	DHDAM		
LEE.G.H				CODE NO			
2010.07.30							
L K HOIST CO., LTD.							

SCHEDULE OF TECHNICAL DATA

1. SERVICE	HOISTING
2. MANUFACTURE	LK HOIST CO. LTD
3. MOTOR MODEL NO	1.8/0.7 - 2/6 - 22
4. RATED POWER	1.8/0.7 KW × 2/6 P
5. RATED VOLTAGE AND FREQUENCY	220 V 60HZ
6. MOTOR TYPE	SQUIRREL CAGE ROTOR TYPE
7. RATING	30 MIN
8. LOCATION	IN-DOOR , OUTDOOR
9. INSULATION CLASS	B
10. DESIGN TEMPERATURE RISE (BY RESISTANCE)	80℃
11. FULL LOAD SPEED	3440/1140 RPM
12. FULL LOAD CURRENT	12/4.5 A
13. STARTING CURRENT AT RATED VOLTAGE	62.4/23.4 A
14. MINIMUM STARTING VOLTAGE	198 V
15. EFFICIENCY AT 100% RATED LOAD	64/64 %
16. POWER FACTOR AT 100% RATED LOAD	64/64 %
17. STARTING TORQUE	235 %
18. TYPE OF ENCLOSURE	전폐형
19. TYPE OF BEARING	PL : 6205DD OPL : 6008ZZ
20. MOUNTING	VERTICAL
21. MAXIMUM AMBIENT TEMPURE	40℃
22. BEARING LUBRICATION	GREASE
23. STARTING METHOD	FULL VOLTAGE

SCHEDULE OF TECHNICAL DATA

1. SERVICE	TRAVERSING
2. MANUFACTURE	LK HOIST CO. LTD
3. MOTOR MODEL NO	0.4 - 4 - 22
4. RATED POWER	0.4 KW × 4 P
5. RATED VOLTAGE AND FREQUENCY	220 V 60HZ
6. ROTOR TYPE	SQUIRREL CAGE ROTOR TYPE
7. RATING	15 MIN
8. LOCATION	IN-DOOR , OUTDOOR
9. INSULATION CLASS	B
10. DESIGN TEMPERATURE RISE (BY RESISTANCE)	100℃
11. FULL LOAD SPEED	1710 RPM
12. FULL LOAD CURRENT	3 A
13. STARTING CURRENT AT RATED VOLTAGE	13.8 A
14. MINIMUM STARTING VOLTAGE	198 V
15. EFFICIENCY AT 100% RATED LOAD	59 %
16. POWER FACTOR AT 100% RATED LOAD	59.3 %
17. STARTING TORQUE	250 %
18. TYPE OF ENCLOSURE	전폐형
19. TYPE OF BEARING	PL : 6202DD OPL : 6004ZZ
20. MOUNTING	VERTICAL
21. MAXIMUM AMBIENT TEMPERATURE	40℃
22. BEARING LUBRICATION	GREASE
23. STARTING METHOD	FULL VOLTAGE

SCHEDULE OF TECHNICAL DATA

1. SERVICE	TRAVERSING
2. MANUFACTURE	LK HOIST CO. LTD
3. MOTOR MODEL NO	0.3 - 6 - 22
4. RATED POWER	0.3 KW × 6 P
5. RATED VOLTAGE AND FREQUENCY	220 V 60HZ
6. ROTOR TYPE	SQUIRREL CAGE ROTOR TYPE
7. RATING	15 MIN
8. LOCATION	IN-DOOR , OUTDOOR
9. INSULATION CLASS	B
10. DESIGN TEMPERATURE RISE (BY RESISTANCE)	100℃
11. FULL LOAD SPEED	1140 RPM
12. FULL LOAD CURRENT	2.5 A
13. STARTING CURRENT AT RATED VOLTAGE	13.7 A
14. MINIMUM STARTING VOLTAGE	198 V
15. EFFICIENCY AT 100% RATED LOAD	57 %
16. POWER FACTOR AT 100% RATED LOAD	55 %
17. STARTING TORQUE	250 %
18. TYPE OF ENCLOSURE	전폐형
19. TYPE OF BEARING	PL : 6008DD OPL : 6207ZZ
20. MOUNTING	VERTICAL
21. MAXIMUM AMBIENT TEMPERATURE	40℃
22. BEARING LUBRICATION	GREASE
23. STARTING METHOD	FULL VOLTAGE

SCHEDULE OF TECHNICAL DATA

1. SERVICE	TRAVERSING
2. MANUFACTURE	LK HOIST CO. LTD
3. MOTOR MODEL NO	0.4/0.14 - 4/12 - 22
4. RATED POWER	0.4/0.14 KW × 4/12 P
5. RATED VOLTAGE AND FREQUENCY	220 V 60HZ
6. MOTOR TYPE	SQUIRREL CAGE ROTOR TYPE
7. RATING	15 MIN
8. LOCATION	IN-DOOR , OUTDOOR
9. INSULATION CLASS	B
10. DESIGN TEMPERATURE RISE (BY RESISTANCE)	100℃
11. FULL LOAD SPEED	1710 / 550 RPM
12. FULL LOAD CURRENT	3 / 1.97 A
13. STARTING CURRENT AT RATED VOLTAGE	14.9/ 9.77 A
14. MINIMUM STARTING VOLTAGE	198 V
15. EFFICIENCY AT 100% RATED LOAD	59.3 / 48.3 %
16. POWER FACTOR AT 100% RATED LOAD	59 / 41.3 %
17. STARTING TORQUE	236 / 237 %
18. TYPE OF ENCLOSURE	전폐형
19. TYPE OF BEARING	PL : 6008DD OPL : 6207ZZ
20. MOUNTING	VERTICAL
21. MAXIMUM AMBIENT TEMPURE	40℃
22. BEARING LUBRICATION	GREASE
23. STARTING METHOD	FULL VOLTAGE