

ON GMD

# L K HOIST

NO	DESCRIPTION	SIZE	MAT'L	Q'TY	WT (kg)	REMARKS
----	-------------	------	-------	------	---------	---------

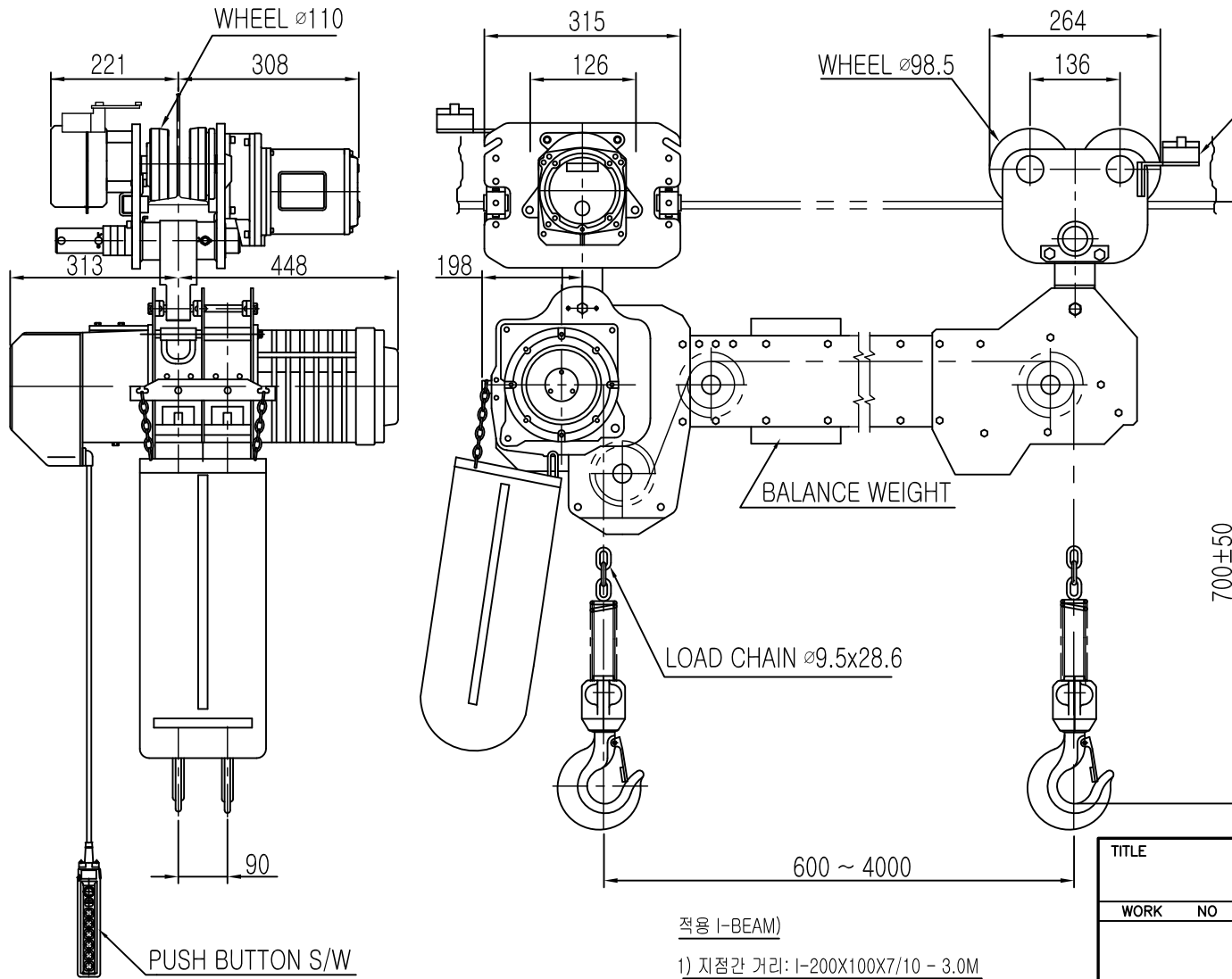

## SPECIFICATION

		LK-DHDAM-1.5S	
RATED LOAD (TON)		1.5	
TESTING LOAD (TON)		1.875	
LIFTING HEIGHT (M)		50	
HOISTING	SPEED (M/MIN)	10.3	
	MOTOR (KW)	3.5kw x 4p	
TRAVERSING	SPEED (M/MIN)	21	14
	MOTOR (KW)	0.75kw x 4p	0.4kw x 6p 0.75/0.25kw x 4/12p
POWER SUPPLY		AC220,380,440,460,480Vx3ø x 60 Hz	
OPERATING METHOD		P.B type ON . FL	
LOAD CHAIN		ø9.5 X 28.6 (1FALL)	
WEIGHT (KG)		580	
I-BEAM 적용폭		100 ~ 190MM	

NOTE)  
 1)점검 설비를 갖출 것  
 2)인허가 서류를 완성검사시 제출 할 것

- 적용 I-BEAM)
- 1) 지점간 거리: I-200X100X7/10 - 3.0M
  - 2) 지점간거리 : I-250X125X7.5/12.5-5.0M
  - 3) 지점간거리 : I-300X150X10/18.5-7.5M
  - 4) 지점간거리 : I-450X175X13/26-11M
  - 5) 지점간거리 : I-600X190X13/25-13M

REV.NO	DATE	REVISION	DESCRIPTION	DRAWN	CHECKED	APPROVED
--------	------	----------	-------------	-------	---------	----------

TITLE					PROJECTION	
ELECTRIC CHAIN HOIST						
WORK NO	WORK NAME				SCALE	Q' TY
	LK-DHDAM-1.5S				N S	1
DRAWN	CHECKED	REVIEWED	APPROVED	DRAWING NO		
김 창 기				CORD NO		
2010.08.01						

ON 9MD

# L K HOIST

NO	DESCRIPTION	SIZE	MAT' L	Q' TY	WT (kg)	REMARKS
----	-------------	------	--------	-------	---------	---------

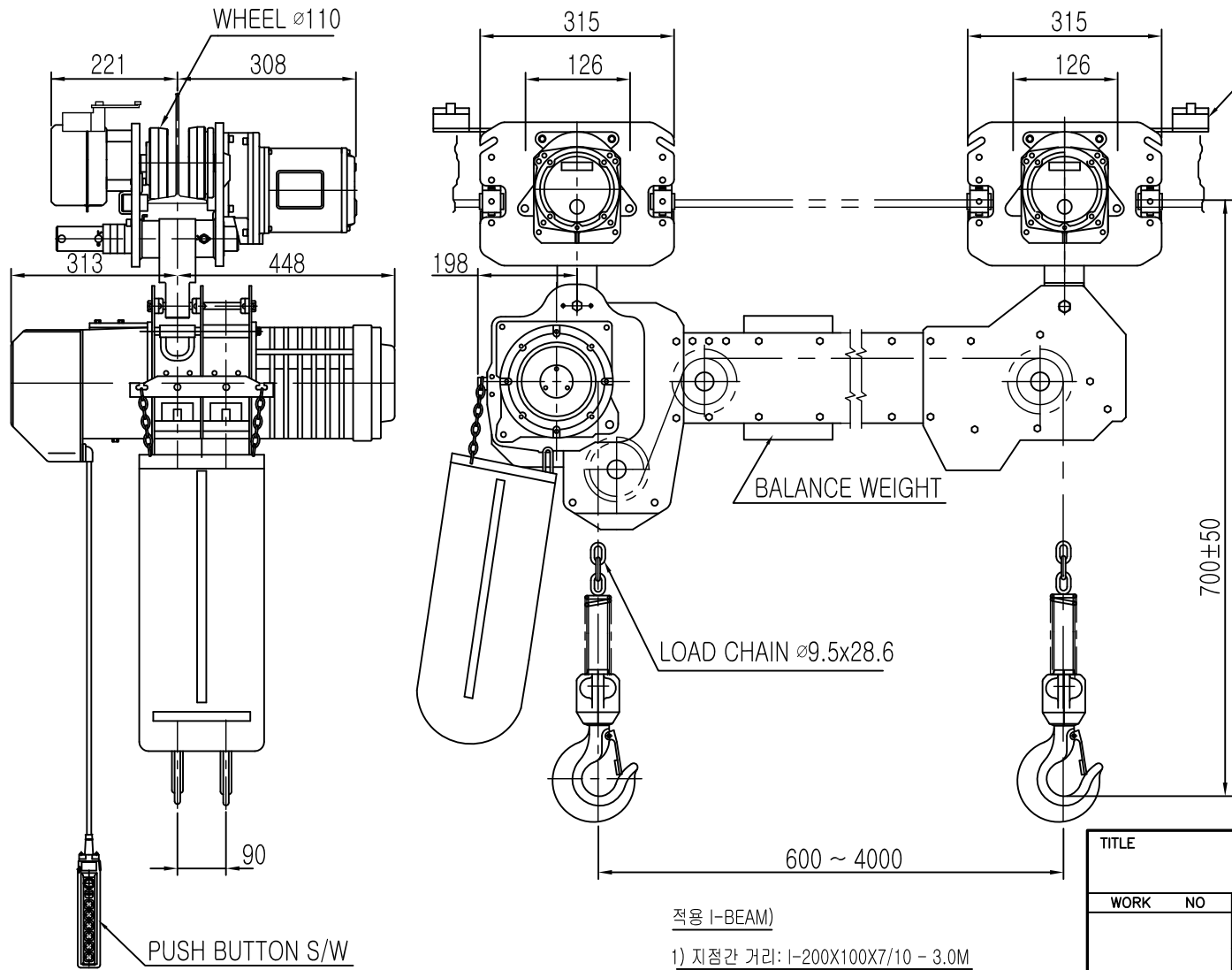

## SPECIFICATION

		LK-DHDAM-1.5S		
RATED LOAD (TON)		1.5		
TESTING LOAD (TON)		1.875		
LIFTING HEIGHT (M)		50		
HOISTING	SPEED (M/MIN)	10.3		
	MOTOR (KW)	3.5kw x 4p		
TRAVERSING	SPEED (M/MIN)	21	14	21/7
	MOTOR (KW)	0.75kwx4p-2set	0.4kwx6p-2set	0.75/0.25kwx4/12p-2set
POWER SUPPLY		AC220.380.440.460.480Vx3ø x 60 Hz		
OPERATING METHOD		P.B type ON . FL		
LOAD CHAIN		ø9.5 X 28.6 (1FALL)		
WEIGHT (KG)		580		
I-BEAM 적용폭		100 ~ 190MM		

NOTE)  
 1)점검 설비를 갖출 것  
 2)인허가 서류를 완성검사시 제출 할 것

- 적용 I-BEAM)
- 1) 지점간 거리: I-200X100X7/10 - 3.0M
  - 2) 지점간거리 : I-250X125X7.5/12.5-5.0M
  - 3) 지점간거리 : I-300X150X10/18.5-7.5M
  - 4) 지점간거리 : I-450X175X13/26-11M
  - 5) 지점간거리 : I-600X190X13/25-13M

REV.NO	DATE	REVISION	DESCRIPTION	DRAWN	CHECKED	APPROVED
--------	------	----------	-------------	-------	---------	----------

TITLE				PROJECTION	
ELECTRIC CHAIN HOIST					
WORK NO	WORK NAME			SCALE	Q' TY
	LK-DHDAM-1.5S			N S	1
DRAWN	CHECKED	REVIEWED	APPROVED	DRAWING NO	CORD NO
김 창 기					
2010.08.01					

**LK** L K HOIST CO., LTD.

ON 5MG

# L K HOIST

NO	DESCRIPTION	SIZE	MAT' L	Q' TY	WT (kg)	REMARKS

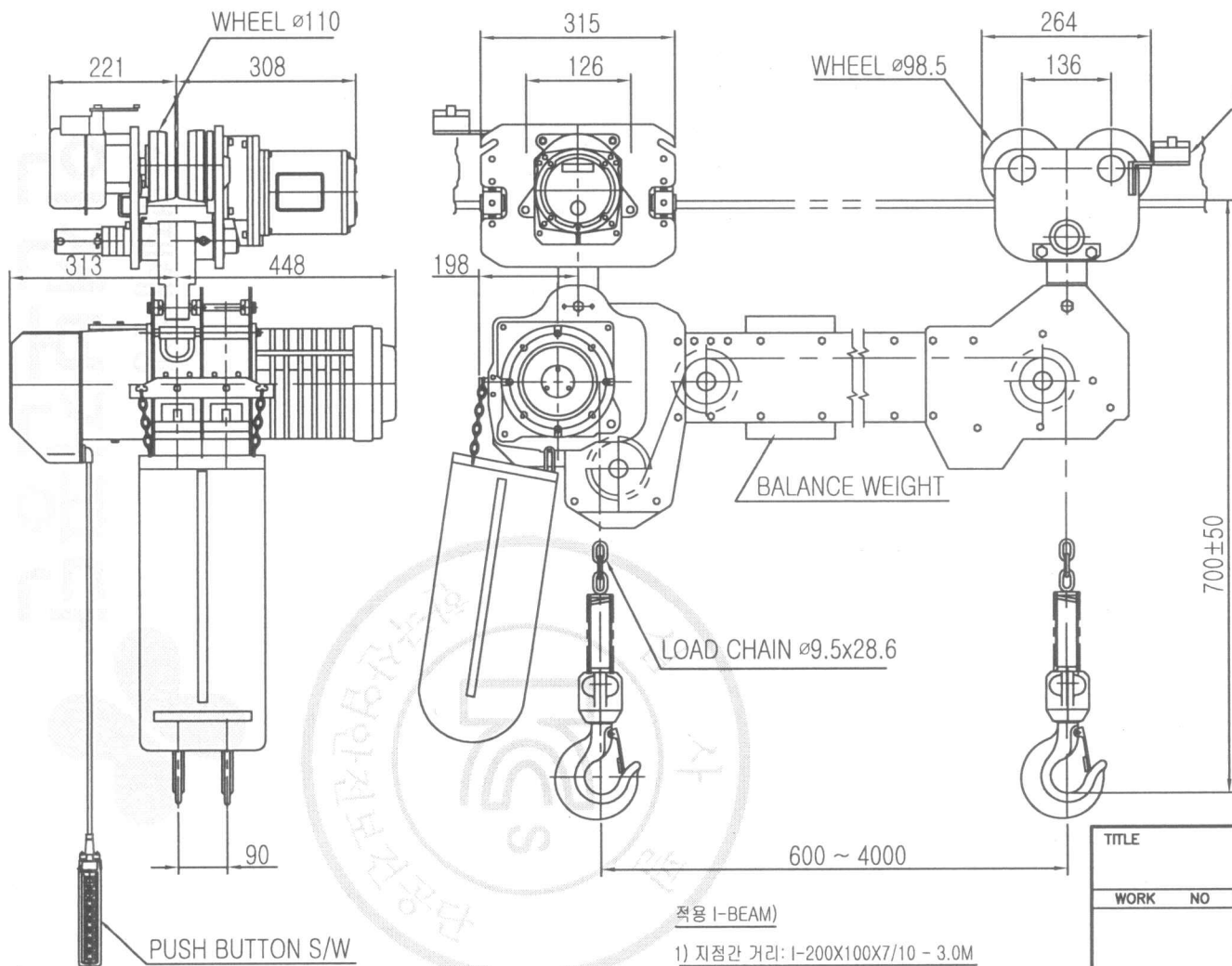

## SPECIFICATION

		LK-DHDAM-1.5S		
RATED LOAD	(TON)	1.5		
TESTING LOAD	(TON)	1.875		
LIFTING HEIGHT	(M)	50		
HOISTING	SPEED (M/MIN)	10.3		
	MOTOR (KW)	3.5kw x 4p		
TRAVERSING	SPEED (M/MIN)	21	14	21/7
	MOTOR (KW)	0.75kw x 4p	0.4kw x 6p	0.75/0.25kw x 4/12p
POWER SUPPLY		AC220.380.440.460.480Vx3ø x 60 Hz		
OPERATING METHOD		P.B type ON . FL		
LOAD CHAIN		ø9.5 X 28.6 (1FALL)		
WEIGHT	(KG)	580		
I-BEAM 적용폭		100 ~ 190MM		

NOTE)

- 1) 점검 설비를 갖추실 것
- 2) 인허가 서류를 완성검사시 제출 할 것

적용 I-BEAM)

- 1) 지점간 거리: I-200X100X7/10 - 3.0M
- 2) 지점간거리 : I-250X125X7.5/12.5-5.0M
- 3) 지점간거리 : I-300X150X10/18.5-7.5M
- 4) 지점간거리 : I-450X175X13/26-11M
- 5) 지점간거리 : I-600X190X13/25-13M

REV.NO	DATE	REVISION	DESCRIPTION	DRAWN	CHECKED	APPROVED

TITLE					PROJECTION	
ELECTRIC CHAIN HOIST						
WORK NO	WORK NAME				SCALE	Q' TY
	LK-DHDAM-1.5S				N S	1
DRAWN	CHECKED	REVIEWED	APPROVED	DRAWING NO		
김창기						
2010.08.01				CORD NO		
<b>L K HOIST CO., LTD.</b>						

일반목적 및 배포금지

ON 5MG

# L K HOIST

NO	DESCRIPTION	SIZE	MAT' L	Q' TY	WT (kg)	REMARKS

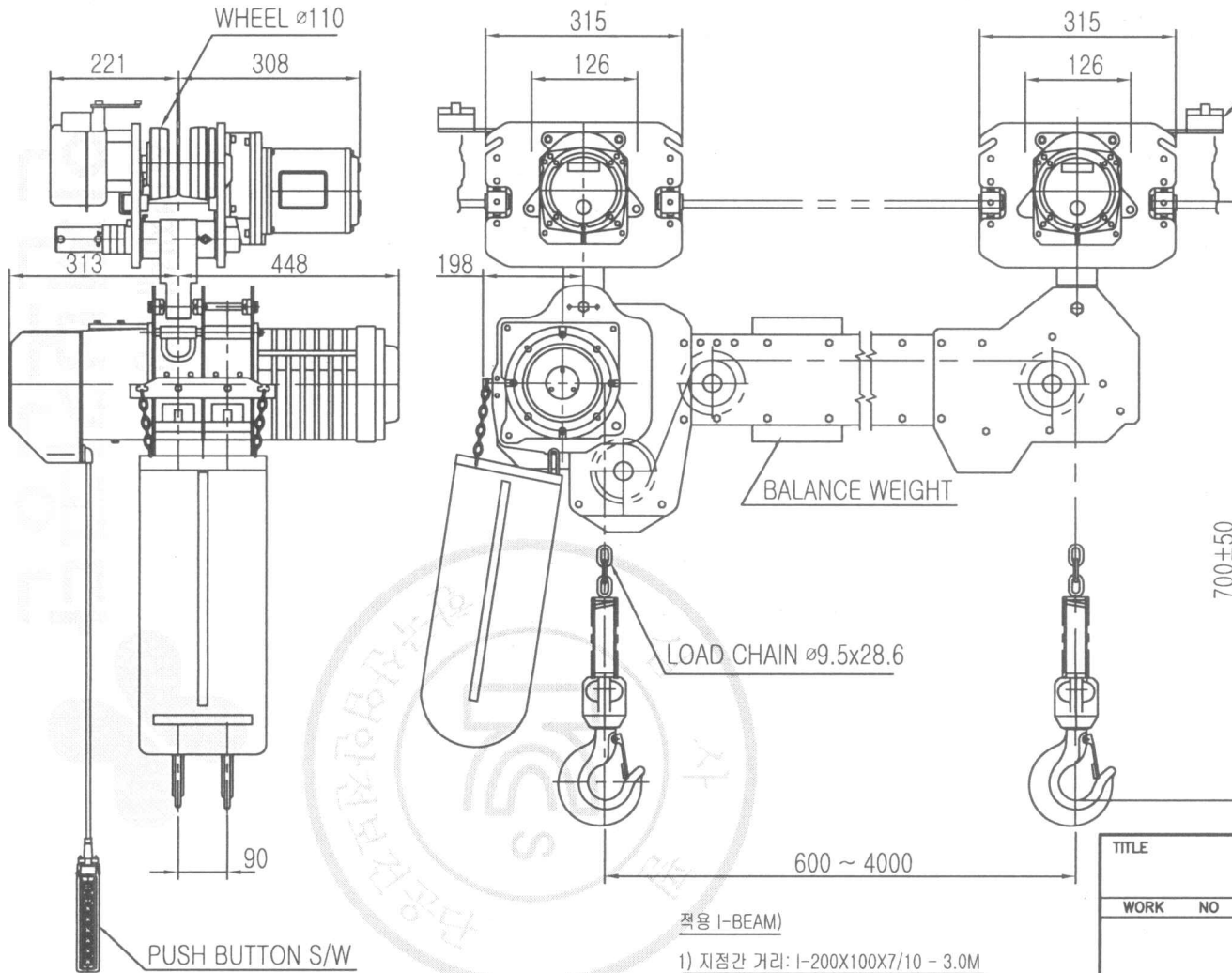

## SPECIFICATION

		LK-DHDAM-1.5S		
RATED LOAD (TON)	1.5			
TESTING LOAD (TON)	1.875			
LIFTING HEIGHT (M)	50			
HOISTING	SPEED (M/MIN)	10.3		
	MOTOR (KW)	3.5kw x 4p		
TRAVERSING	SPEED (M/MIN)	21	14	21/7
	MOTOR (KW)	0.75kwx4p-2set	0.4kwx6p-2set	0.75/0.25kwx4/12p-2set
POWER SUPPLY	AC220.380.440.460.480Vx3ø x 60 Hz			
OPERATING METHOD	P.B type ON . FL			
LOAD CHAIN	ø9.5 X 28.6 (1FALL)			
WEIGHT (KG)	580			
I-BEAM 적용폭	100 ~ 190MM			

NOTE)  
 1)정검 설비를 갖출 것  
 2)인허가 서류를 완성검사시 제출 할 것

- 적용 I-BEAM)
- 1) 지점간 거리 : I-200X100X7/10 - 3.0M
  - 2) 지점간 거리 : I-250X125X7.5/12.5-5.0M
  - 3) 지점간 거리 : I-300X150X10/18.5-7.5M
  - 4) 지점간 거리 : I-450X175X13/26-11M
  - 5) 지점간 거리 : I-600X190X13/25-13M

REV.NO	DATE	REVISION	DESCRIPTION	DRAWN	CHECKED	APPROVED

TITLE				ELECTRIC CHAIN HOIST		PROJECTION	
WORK NO		WORK NAME		SCALE		Q' TY	
		LK-DHDAM-1.5S		N S		1	
DRAWN	CHECKED	REVIEWED	APPROVED	DRAWING NO			
김 창 기				CORD NO			
2010.08.01							

물범목재 및 배포금지