

-NOTE-

1. ----- MARKER OWNER SCOPE
2. 24V인 경우 F21는 3A 적용

SPECIFICATION	NO FUSE BREAKER	MAGNET CONTACT		TRANSFORMER	FUZE
SYMBOLS	MCCB0	M0		TR10	F11, F12, F21
DESCRIPTION	220V	20A	GMC18	DMC18	30VA
	380V	10A			
	440V	10A			
	460V	10A			
	480V	10A			
MAKER	LS	LS	DONGA	LK	-

TITLE MAIN POWER & CONTROL CIRCUIT DIAGRAM				PROJECTION	
WORK NO 601		WORK NAME LDUH		SCALE 1/1	Q' TY 1
DRAWN LEE.G.H	CHECKED	REVIEWED	APPROVED	DRAWING NO	CODE NO
2010.10.13					
<b>L K HOIST CO., LTD.</b>					

HOISTING POWER  
(A1/3)(A1/3)(A1/3)(A1/3)

--- PENDANT SWITCH ---

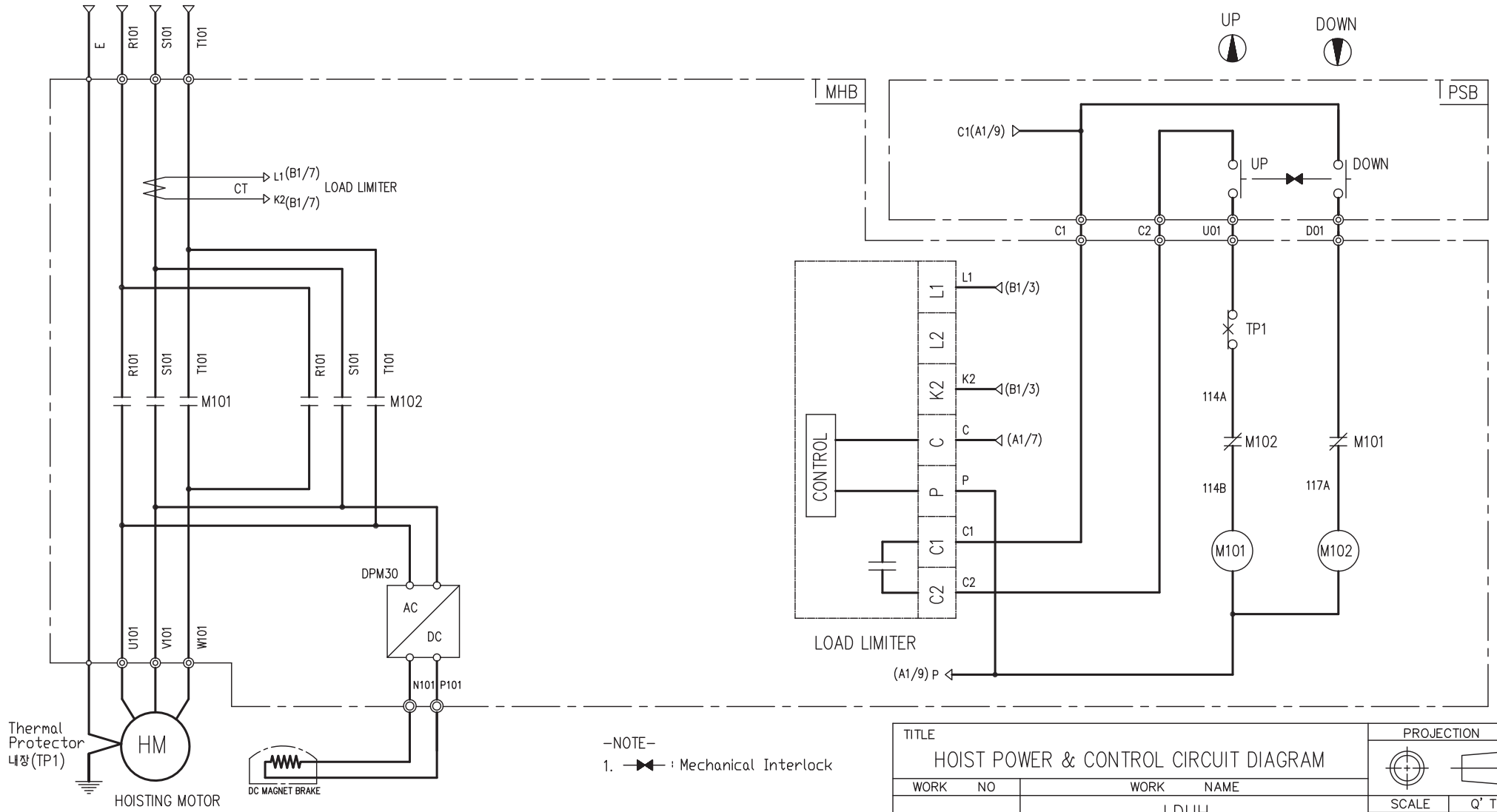

-NOTE-  
1. : Mechanical Interlock

SPECIFICATION	MAGNET CONTACT	SILICON RECTIFIER				LOAD LIMITER	Thermal Protector	HOIST MOTOR
SYMBOLS	M101, M102	DPM30				-	TP1	HM
		AC220V	AC440V	AC460V	AC480V			
DESCRIPTION	GMC12   DMC12	DC99V	DC198V	DC207V	DC216V	LKDL-501	17AM032	1.5Kw * 6P
MAKER	LS   DONGA	LK				LK	Texas Instruments	LK

TITLE HOIST POWER & CONTROL CIRCUIT DIAGRAM						PROJECTION 	
WORK NO 602		WORK NAME LDUH				SCALE 1/1	Q' TY 1
220V, 440V, 460V, 480V							
DRAWN LEE.G.H	CHECKED	REVIEWED	APPROVED	MODEL			
2010.10.13				CODE NO			
<b>L K HOIST CO., LTD.</b>							

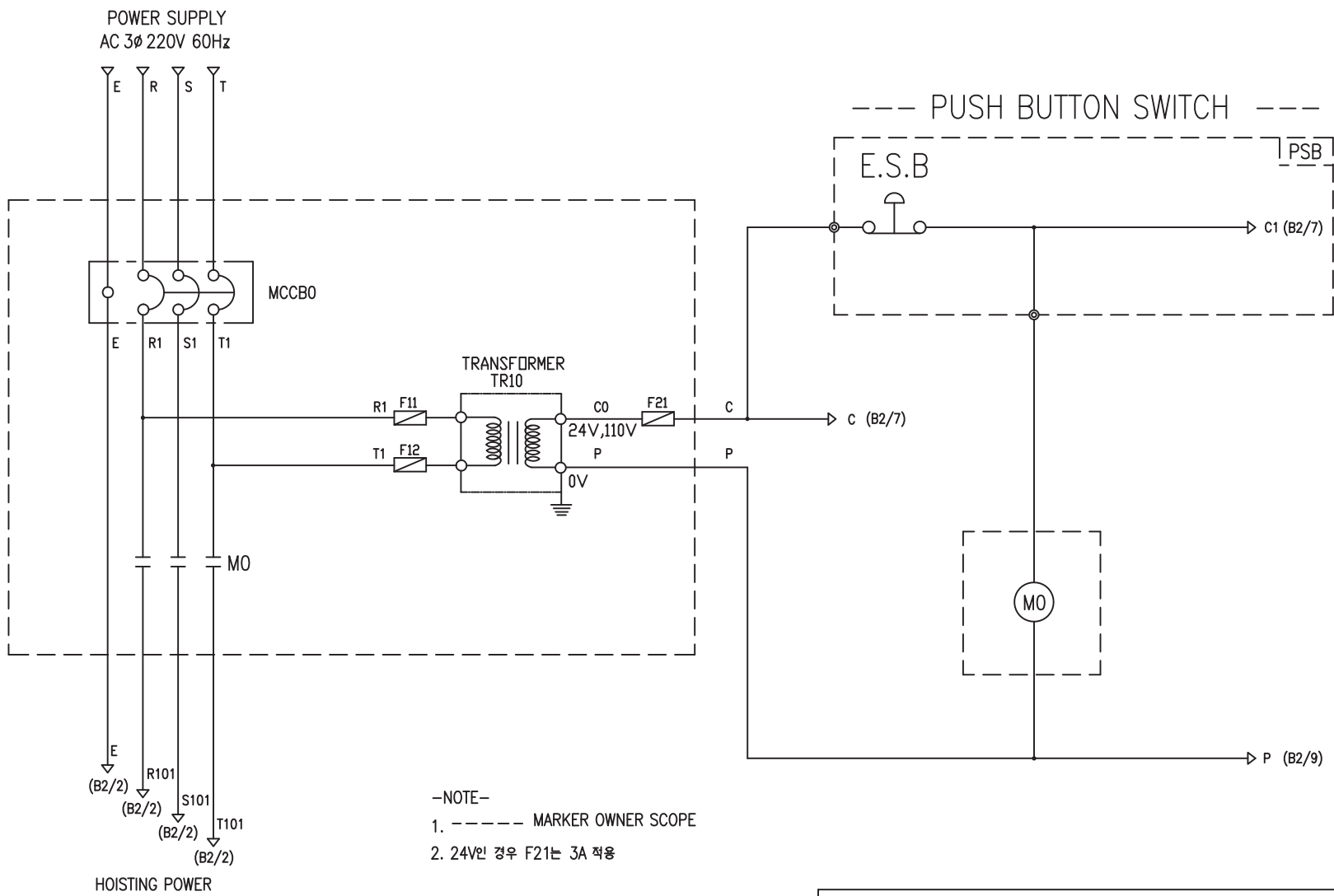

-NOTE-

1. ----- MARKER OWNER SCOPE
2. 24V인 경우 F21는 3A 적용

SPECIFICATION	NO FUSE BREAKER	MAGNET CONTACT	TRANSFORMER	FUZE
SYMBOLS	MCCB0	M0	TR10	F11, F12, F21
DESCRIPTION	220V	20A	30VA	1A
	380V	10A		
	440V	10A		
	460V	10A		
	480V	10A		
MAKER	LS	LS	DONGA	LK

TITLE MAIN POWER & CONTROL CIRCUIT DIAGRAM				PROJECTION	
WORK NO 604		WORK NAME LDUH		SCALE 1/1	Q' TY 1
DRAWN LEE.G.H	CHECKED	REVIEWED	APPROVED	DRAWING NO	CODE NO
2010.10.13					
<b>L K HOIST CO., LTD.</b>					

HOISTING POWER

(A2/3)(A2/3)(A2/3)(A2/3)

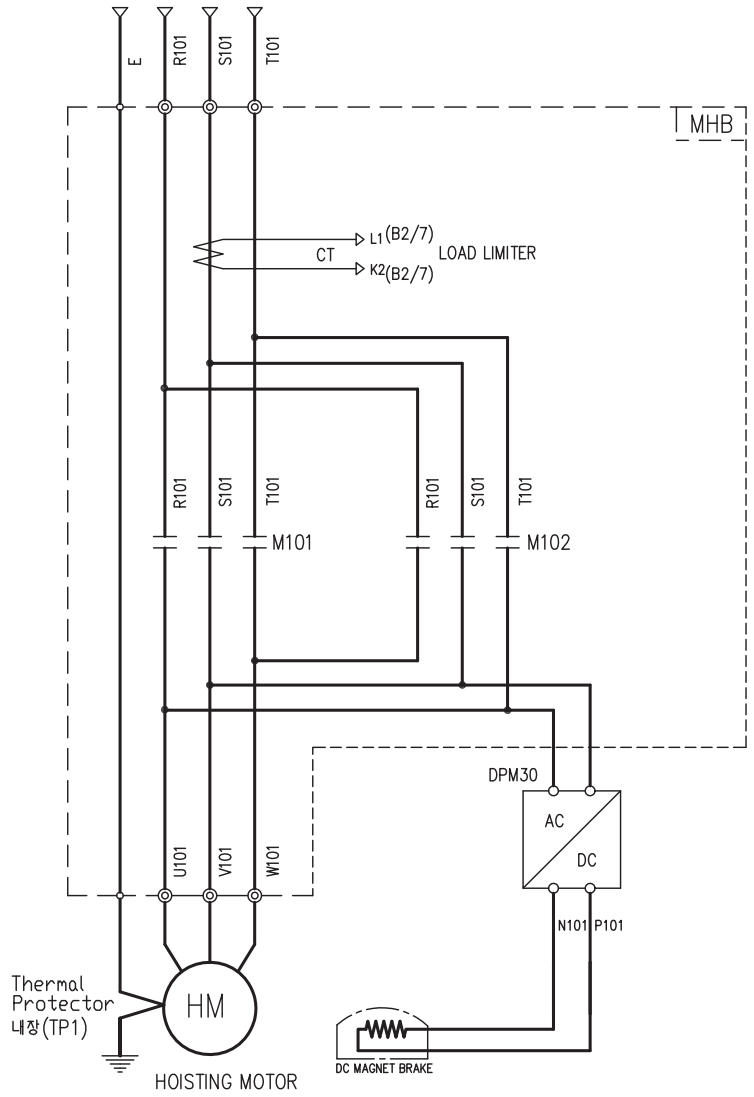

-- PUSH BUTTON SWITCH --

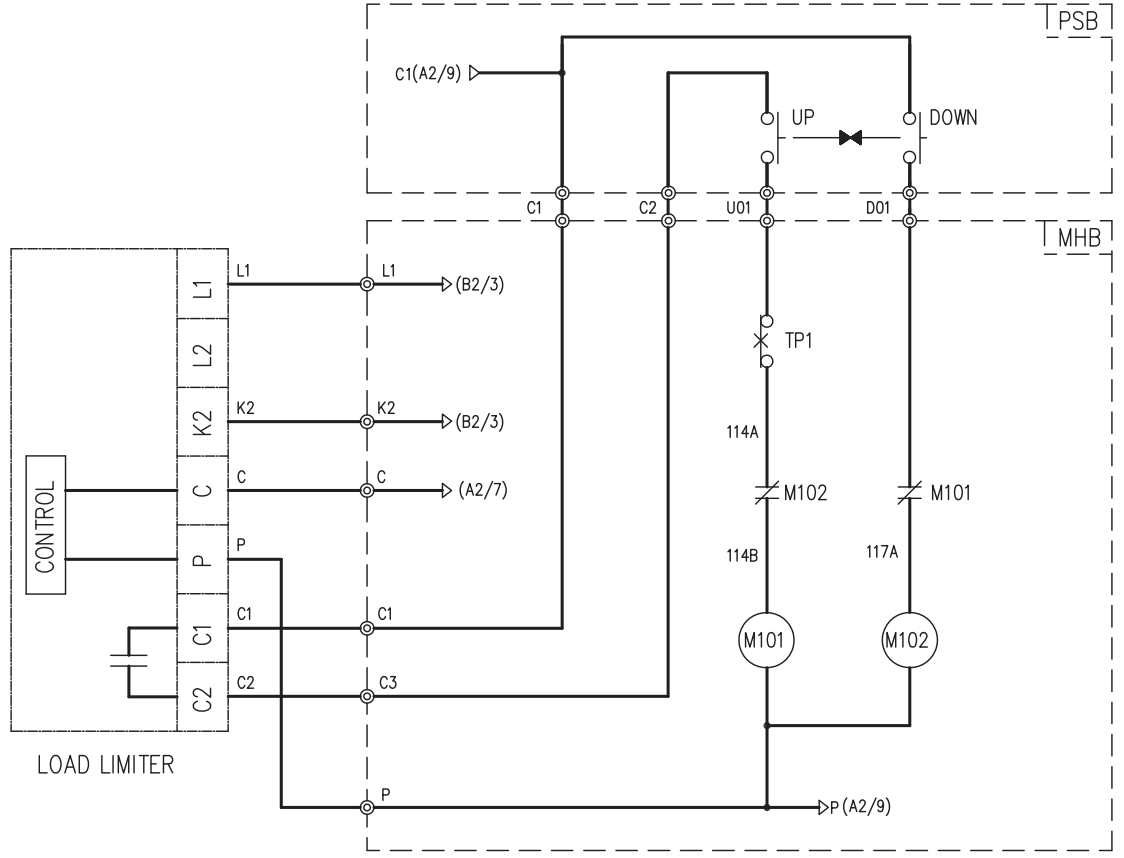
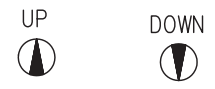

- NOTE-
- : Mechanical Interlock
  - : Marker owner scope

TITLE						PROJECTION	
HOIST POWER & CONTROL CIRCUIT DIAGRAM							
WORK NO		WORK NAME				SCALE	
605		LDUH				1/1	
		220V, 440V, 460V, 480V				Q' TY	
						1	
DRAWN	CHECKED	REVIEWED	APPROVED	MODEL			
LEE.G.H				CODE NO			
2010.10.13							
<b>L K HOIST CO., LTD.</b>							

SPECIFICATION	MAGNET CONTACT		SILICON RECTIFIER			LOAD LIMITER	Thermal Protector	HOIST MOTOR	
SYMBOLS	M101, M102		DPM30			-	TP1	HM	
			AC220V	AC440V	AC460V	AC480V			
DESCRIPTION	GMC12	DMC12	DC99V	DC198V	DC207V	DC216V	LKDL-501	17AM032	1.5Kw * 6P
MAKER	LS	DONGA	LK			LK	Texas Instruments	LK	

## SCHEDULE OF TECHNICAL DATA

1. SERVICE	HOISTING
2. MANUFACTURE	LK HOIST CO. LTD
3. MOTOR MODEL NO	1.5 - 6 - 46
4. RATED POWER	1.5 KW × 6 P
5. RATED VOLTAGE AND FREQUENCY	460 V      60HZ
6. MOTOR TYPE	SQUIRREL CAGE ROTOR TYPE
7. RATING	30 MIN
8. LOCATION	IN-DOOR , OUTDOOR
9. INSULATION CLASS	B
10. DESIGN TEMPERATURE RISE (BY RESISTANCE)	80℃
11. FULL LOAD SPEED	1150 RPM
12. FULL LOAD CURRENT	4.3 A
13. STARTING CURRENT AT RATED VOLTAGE	20.8 A
14. MINIMUM STARTING VOLTAGE	419 V
15. EFFICIENCY AT 100% RATED LOAD	68.5 %
16. POWER FACTOR AT 100% RATED LOAD	63.9 %
17. STARTING TORQUE	246 %
18. TYPE OF ENCLOSURE	전폐형
19. TYPE OF BEARING	PL : 6008DD    OPL : 6207ZZ
20. MOUNTING	VERTICAL
21. MAXIMUM AMBIENT TEMPURE	40℃
22. BEARING LUBRICATION	GREASE
23. STARTING METHOD	FULL VOLTAGE