

-NOTE-

1. ----- MARKER OWNER SCOPE
2. 24V인 경우 F21는 3A 적용

SPECIFICATION	NO FUSE BREAKER	MAGNET CONTACT	TRANSFORMER	FUZE	
SYMBOLS	MCCB0	M0	TR10	F11, F12, F21	
DESCRIPTION	220V	20A	30VA	1A	
	380V	10A			
	440V	10A			
	460V	10A			
	480V	10A			
MAKER	LS	LS	DONGA	LK	-

TITLE MAIN POWER & CONTROL CIRCUIT DIAGRAM						PROJECTION 	
WORK NO 601		WORK NAME DHDA				SCALE 1/1	
220V, 380V, 440V, 460V, 480V		Q' TY 1					
DRAWN LEE.G.H	CHECKED	REVIEWED	APPROVED	MODEL	DHDA		
2010.07.30				CODE NO			
L K HOIST CO., LTD.							

HOIST POWER CIRCUIT

HOIST CONTROL CIRCUIT

HOISTING POWER
(A1/3)(A1/3)(A1/3)(A1/3)

----- PENDANT SWITCH -----
UP DOWN

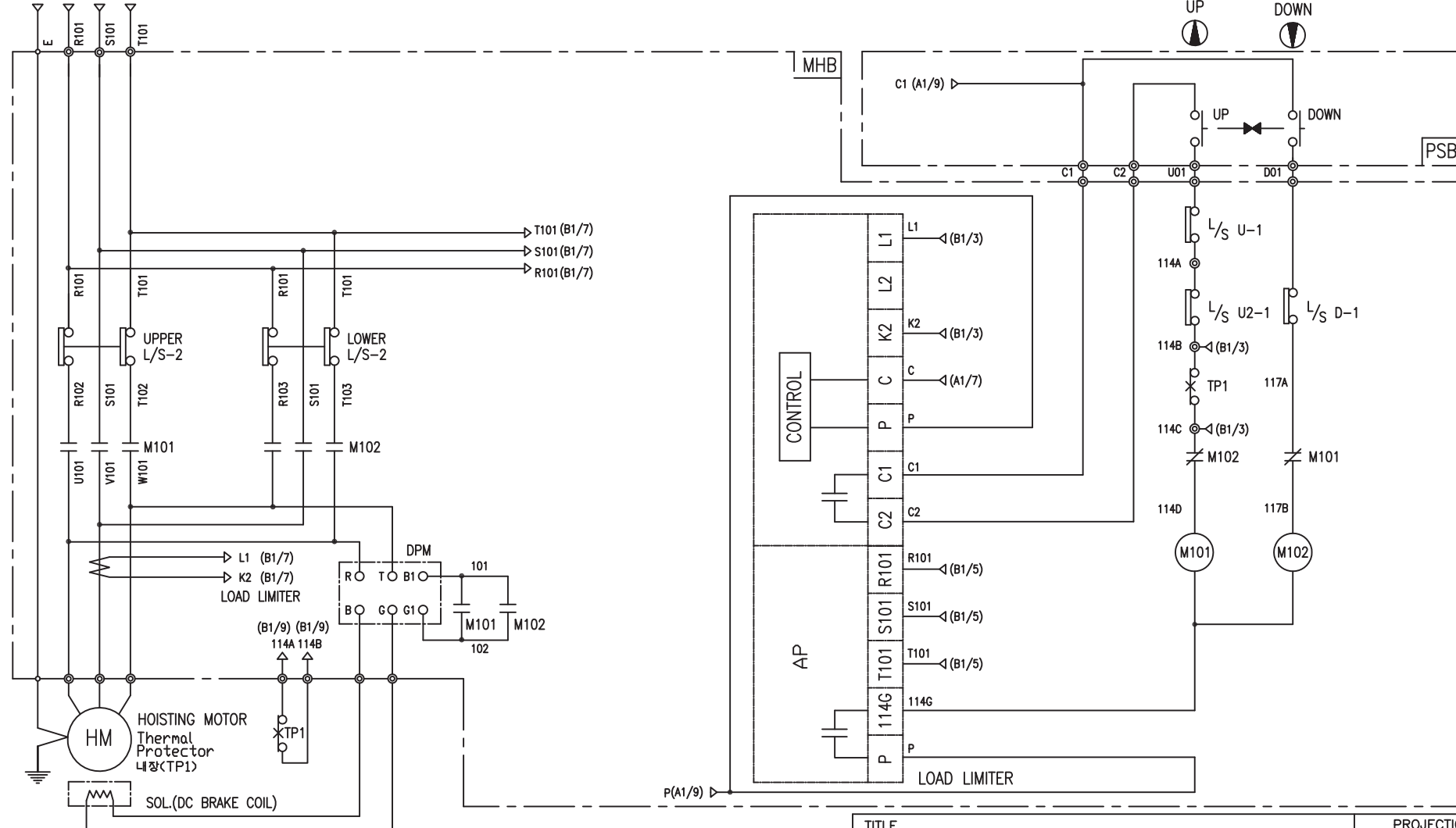

-NOTE-
1. —|— : Mechanical Interlock

SPECIFICATION	MAGNET CONTACT		LOAD LIMITER	SILICON RECTIFIER				Thermal Protector	HOIST MOTOR
SYMBOLS	M101, M102		-	DPM				TP1	HM
DESCRIPTION	DMC-12	GMC-12	LKDL-601	AC220V	AC440V	AC460V	AC480V	17AM032	1.8Kw * 4P
				DC99V	DC198V	DC207V	DC216V		
MAKER	DONG-A	LS	LK	LK				Texas Instruments	LK

TITLE HOIST POWER & CONTROL CIRCUIT DIAGRAM						PROJECTION First Angle Projection	
WORK NO.	WORK NAME					SCALE	Q' TY
602	DHDA					1/1	1
220V, 440V, 460V, 480V							
DRAWN	CHECKED	REVIEWED	APPROVED	MODEL	DHDA		
LEE.G.H				CODE NO			
2010.07.30							
LK L K HOIST CO., LTD.							

SCHEDULE OF TECHNICAL DATA

1. SERVICE	HOISTING
2. MANUFACTURE	LK HOIST CO. LTD
3. MOTOR MODEL NO	1.8 - 4 - 46
4. RATED POWER	1.8 KW × 4 P
5. RATED VOLTAGE AND FREQUENCY	460 V 60HZ
6. MOTOR TYPE	SQUIRREL CAGE ROTOR TYPE
7. RATING	30 MIN
8. LOCATION	IN-DOOR , OUTDOOR
9. INSULATION CLASS	B
10. DESIGN TEMPERATURE RISE (BY RESISTANCE)	80℃
11. FULL LOAD SPEED	1740 RPM
12. FULL LOAD CURRENT	4.5 A
13. STARTING CURRENT AT RATED VOLTAGE	22.2 A
14. MINIMUM STARTING VOLTAGE	397 V
15. EFFICIENCY AT 100% RATED LOAD	72.4 %
16. POWER FACTOR AT 100% RATED LOAD	69.4 %
17. STARTING TORQUE	246 %
18. TYPE OF ENCLOSURE	전폐형
19. TYPE OF BEARING	PL : 6008DD OPL : 6207ZZ
20. MOUNTING	VERTICAL
21. MAXIMUM AMBIENT TEMPURE	40℃
22. BEARING LUBRICATION	GREASE
23. STARTING METHOD	FULL VOLTAGE