

TRAVELLING POWER
SUPPLY SYSTEM
TB1(Trolley Bar
or Festoon Type)



(B1/3) (B1/3) (B1/3) (B1/3)
(B2/3) (B2/3) (B2/3) (B2/3)
HOISTING & TRAVERSING
POWER

MAIN POWER SOURCE
AC 3Ø60Hz 220V, 380V, 440V, 460V, 480V

-NOTE-

- 1. - - - - MARKED OWNER SCOPE
- 2. ———— MARKED CRANE MAKER SCOPE

TITLE MAIN POWER CIRCUIT DIAGRAM1					PROJECTION 	
WORK NO	WORK NAME				SCALE	Q' TY
601	DBD				1/1	1
220V, 380V, 440V, 460V, 480V						
DRAWN	CHECKED	REVIEWED	APPROVED	MODEL		
LEE.G.H				CODE NO		
2010.08.06						
L K HOIST CO., LTD.						

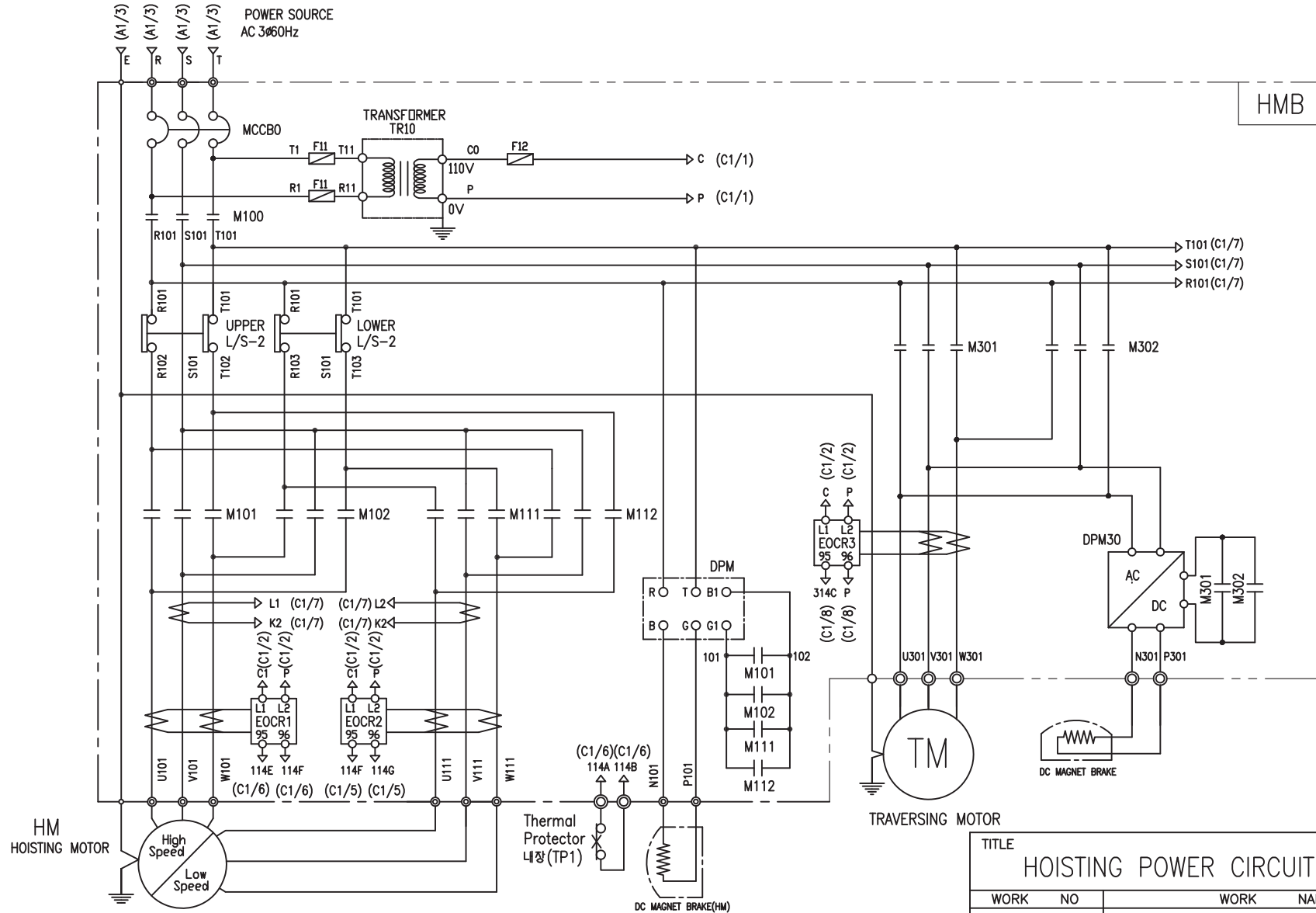

HMB

TITLE HOISTING POWER CIRCUIT DIAGRAM				PROJECTION 	
WORK NO 602		WORK NAME DBD			
		220V, 440V, 460V, 480V			
SCALE	Q' TY				
DRAWN LEE.G.H	CHECKED	REVIEWED	APPROVED	MODEL	
2010.08.06				CODE NO	CODE_NO
LK L K HOIST CO., LTD.					

SPECIFICATION	NO FUSE BREAKER	MAGNET CONTACTOR	TRANSFORMER	SILICON RECTIFIER				과전류계전기	FUSE	HOISTING MOTOR	TRAVERSING MOTOR				
	MCCB0	M100, M101, M102, M111, M112	TR10	DPM, DPM30				EOCR1, EOCR2	EOCR3	F11, F12	HM	TM			
SYMBOLS															
DESCRIPTION	220V	30A	DMC22	DMC12	60 VA	AC220V	AC440V	AC460V	AC480V	SS-30	SS-06	1A	2A	1.8Kw x 2P / 0.7Kw x 6P	0.75Kw * 4P / 0.5Kw * 6P
	460V	15A				DC99V	DC198V	DC207V	DC216V						
	460V	15A													
	480V	15A													
MAKER	LS	DONGA	YOUNG DONG	LK				SAMWHA	-	LK	LK				

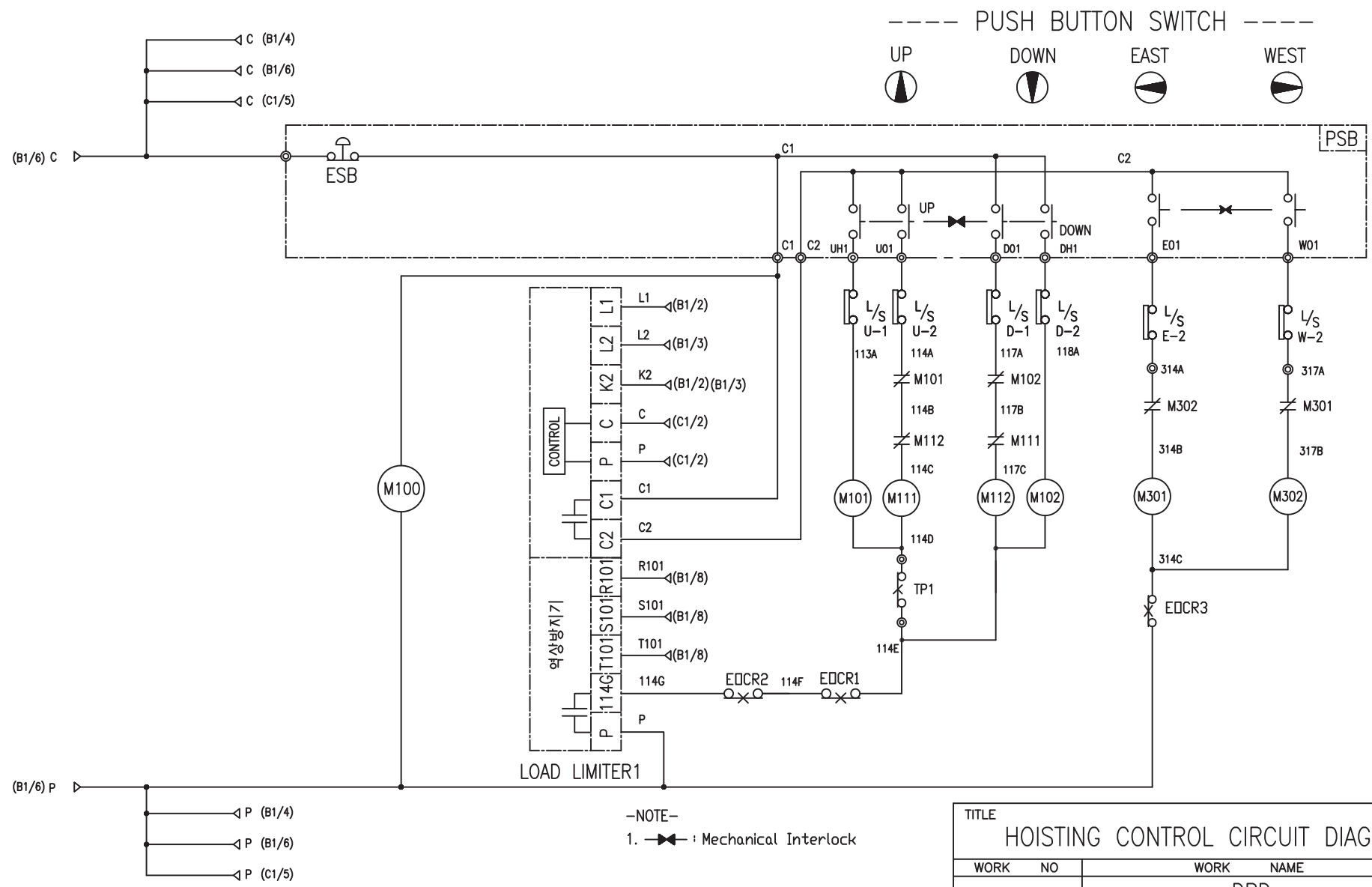

-NOTE-
1. ——— : Mechanical Interlock

SPECIFICATION	LOAD LIMITER
SYMBOLS	LKDL601
DESCRIPTION	1A - 50A
MAKER	LK

TITLE HOISTING CONTROL CIRCUIT DIAGRAM				PROJECTION 	
WORK NO. 604	WORK NAME DBD			SCALE	Q' TY
220V, 380V, 440V, 460V, 480V					
DRAWN LEE.G.H	CHECKED	REVIEWED	APPROVED	MODEL	
2010.08.06				CODE NO	CODE_NO
L K HOIST CO., LTD.					

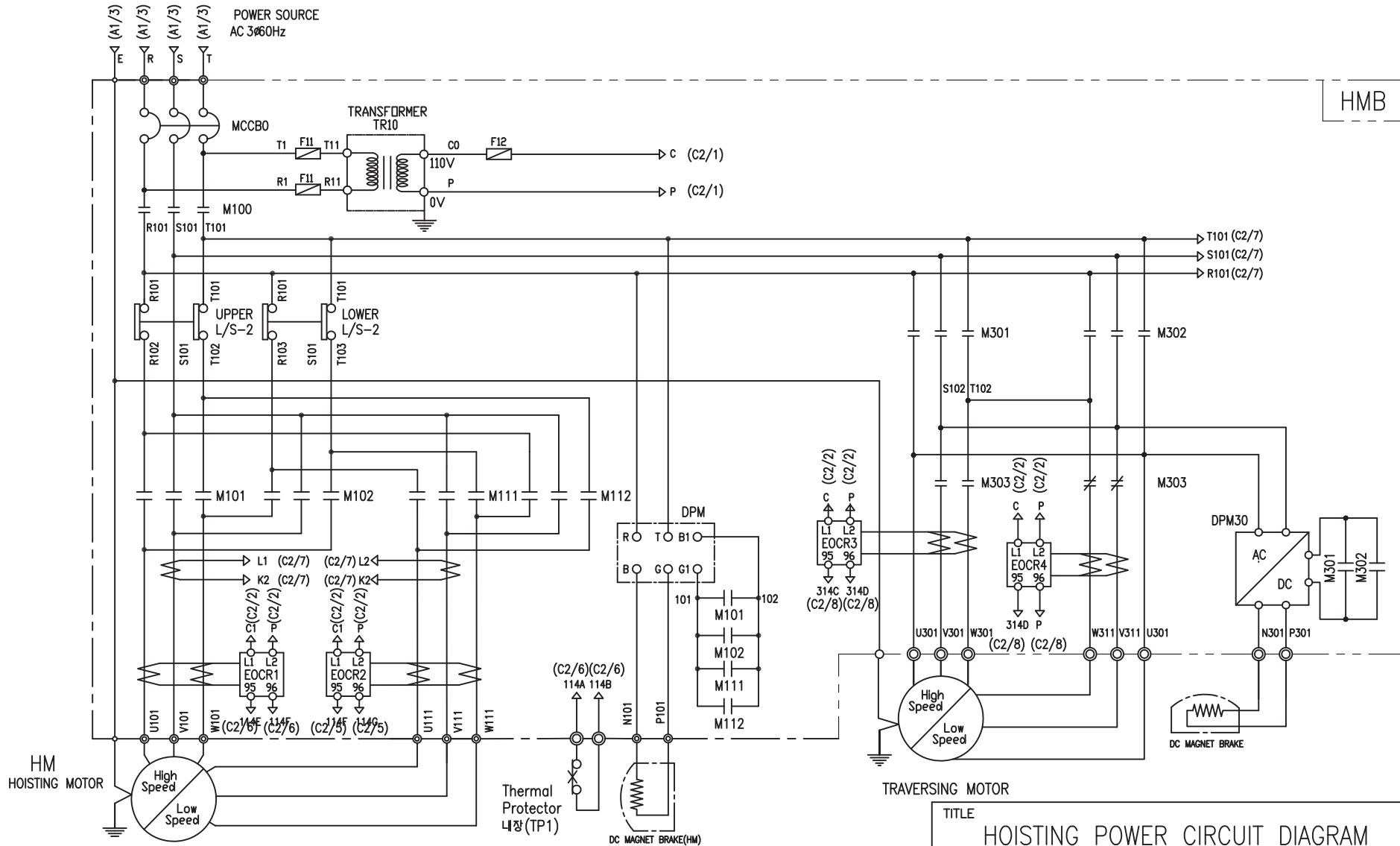

TITLE				PROJECTION	
HOISTING POWER CIRCUIT DIAGRAM					
WORK NO		WORK NAME		SCALE	
605		DBD		Q' TY	
220V, 440V, 460V, 480V					
DRAWN	CHECKED	REVIEWED	APPROVED	MODEL	
LEE.G.H				CODE NO	
2010.08.06				CODE_NO	
L K HOIST CO., LTD.					

SPECIFICATION	NO FUSE BREAKER	MAGNET CONTACTOR	TRANSFORMER	SILICON RECTIFIER				과전류계전기	FUSE	HOISTING MOTOR	TRAVERSING MOTOR	
	MCCBO	M100, M101, M102, M111, M112	TR10	DPM, DPM30				EOCR1, EOCR2, EOCR3, EOCR4	F11, F12	HM	TM	
DESCRIPTION	220V 30A 380V 20A 440V 15A 460V 15A 480V 15A	DMC22	DMC12	60 VA	AC220V DC99V	AC440V DC198V	AC460V DC207V	AC480V DC216V	SS-30 1A	SS-06 2A	1.8Kw x 2P / 0.7Kw x 6P	0.75Kw * 4P / 0.25Kw * 6P
MAKER	LS	DONGA	YOUNG DONG	LK				SAMWHA	-	LK	LK	

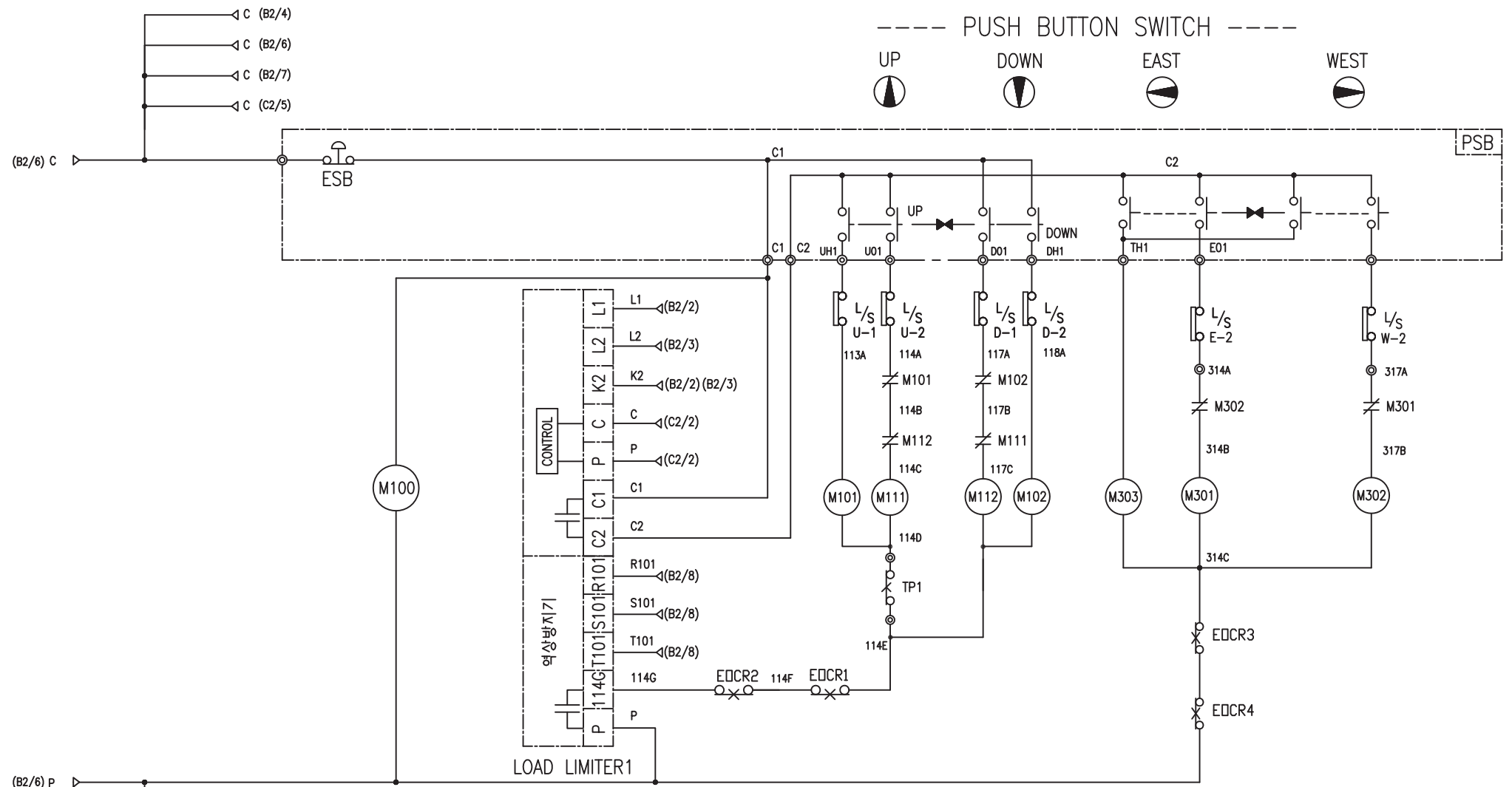

-NOTE-
1. ——— : Mechanical Interlock

SPECIFICATION	LOAD LIMITER
SYMBOLS	LKDL601
DESCRIPTION	1A - 50A
MAKER	LK

TITLE HOISTING CONTROL CIRCUIT DIAGRAM				PROJECTION 	
WORK NO 606	WORK NAME DBD			SCALE	Q' TY
220V, 380V, 440V, 460V, 480V					
DRAWN LEE.G.H	CHECKED	REVIEWED	APPROVED	MODEL	
2010.08.06				CODE NO	CODE_NO
L K HOIST CO., LTD.					

SCHEDULE OF TECHNICAL DATA

1. SERVICE	HOISTING
2. MANUFACTURE	LK HOIST CO. LTD
3. MOTOR MODEL NO	1.8/0.7 - 2/6 - 46
4. RATED POWER	1.8/0.7 KW × 2/6 P
5. RATED VOLTAGE AND FREQUENCY	460 V 60HZ
6. MOTOR TYPE	SQUIRREL CAGE ROTOR TYPE
7. RATING	30 MIN
8. LOCATION	IN-DOOR , OUTDOOR
9. INSULATION CLASS	B
10. DESIGN TEMPERATURE RISE (BY RESISTANCE)	80℃
11. FULL LOAD SPEED	3440/1140 RPM
12. FULL LOAD CURRENT	5.7/2.0 A
13. STARTING CURRENT AT RATED VOLTAGE	30/11 A
14. MINIMUM STARTING VOLTAGE	414 V
15. EFFICIENCY AT 100% RATED LOAD	64/64 %
16. POWER FACTOR AT 100% RATED LOAD	64/64 %
17. STARTING TORQUE	235 %
18. TYPE OF ENCLOSURE	전폐형
19. TYPE OF BEARING	PL : 6205DD OPL : 6008ZZ
20. MOUNTING	VERTICAL
21. MAXIMUM AMBIENT TEMPURE	40℃
22. BEARING LUBRICATION	GREASE
23. STARTING METHOD	FULL VOLTAGE

SCHEDULE OF TECHNICAL DATA

1. SERVICE	TRAVERSING
2. MANUFACTURE	LK HOIST CO. LTD
3. MOTOR MODEL NO	0.75 - 4 - 46
4. RATED POWER	0.75 KW × 4 P
5. RATED VOLTAGE AND FREQUENCY	460 V 60HZ
6. MOTOR TYPE	SQUIRREL CAGE ROTOR TYPE
7. RATING	15 MIN
8. LOCATION	OUTDOOR
9. INSULATION CLASS	B
10. DESIGN TEMPERATURE RISE (BY RESISTANCE)	100℃
11. FULL LOAD SPEED	1710 RPM
12. FULL LOAD CURRENT	2.3 A
13. STARTING CURRENT AT RATED VOLTAGE	12.6 A
14. MINIMUM STARTING VOLTAGE	414 V
15. EFFICIENCY AT 100% RATED LOAD	65 %
16. POWER FACTOR AT 100% RATED LOAD	63 %
17. STARTING TORQUE	250 %
18. TYPE OF ENCLOSURE	전폐형
19. TYPE OF BEARING	PL : 6008DD OPL : 6207ZZ
20. MOUNTING	VERTICAL
21. MAXIMUM AMBIENT TEMPURE	40℃
22. BEARING LUBRICATION	GREASE
23. STARTING METHOD	FULL VOLTAGE

SCHEDULE OF TECHNICAL DATA

1. SERVICE	TRAVERSING
2. MANUFACTURE	LK HOIST CO. LTD
3. MOTOR MODEL NO	0.5 - 6 - 46
4. RATED POWER	0.5 KW × 6 P
5. RATED VOLTAGE AND FREQUENCY	460 V 60HZ
6. ROTOR TYPE	SQUIRREL CAGE ROTOR TYPE
7. RATING	15 MIN
8. LOCATION	OUTDOOR
9. INSULATION CLASS	B
10. DESIGN TEMPERATURE RISE (BY RESISTANCE)	100℃
11. FULL LOAD SPEED	1140 RPM
12. FULL LOAD CURRENT	1.53 A
13. STARTING CURRENT AT RATED VOLTAGE	8.4 A
14. MINIMUM STARTING VOLTAGE	414 V
15. EFFICIENCY AT 100% RATED LOAD	65 %
16. POWER FACTOR AT 100% RATED LOAD	63 %
17. STARTING TORQUE	249 %
18. TYPE OF ENCLOSURE	전폐형
19. TYPE OF BEARING	PL : 6008DD OPL : 6207ZZ
20. MOUNTING	VERTICAL
21. MAXIMUM AMBIENT TEMPERATURE	40℃
22. BEARING LUBRICATION	GREASE
23. STARTING METHOD	FULL VOLTAGE

SCHEDULE OF TECHNICAL DATA

1. SERVICE	TRAVERSING
2. MANUFACTURE	LK HOIST CO. LTD
3. MOTOR MODEL NO	0.75/0.25 - 4/12 - 46
4. RATED POWER	0.75/0.25 KW × 4/12 P
5. RATED VOLTAGE AND FREQUENCY	460 V 60HZ
6. MOTOR TYPE	SQUIRREL CAGE ROTOR TYPE
7. RATING	15 MIN
8. LOCATION	OUTDOOR
9. INSULATION CLASS	B
10. DESIGN TEMPERATURE RISE (BY RESISTANCE)	100℃
11. FULL LOAD SPEED	1710 / 550 RPM
12. FULL LOAD CURRENT	2.3 / 1.44 A
13. STARTING CURRENT AT RATED VOLTAGE	12.7 / 7.92 A
14. MINIMUM STARTING VOLTAGE	414 V
15. EFFICIENCY AT 100% RATED LOAD	65 / 48 %
16. POWER FACTOR AT 100% RATED LOAD	63 / 45 %
17. STARTING TORQUE	250 / 243 %
18. TYPE OF ENCLOSURE	전폐형
19. TYPE OF BEARING	PL : 6008DD OPL : 6207ZZ
20. MOUNTING	VERTICAL
21. MAXIMUM AMBIENT TEMPURE	40℃
22. BEARING LUBRICATION	GREASE
23. STARTING METHOD	FULL VOLTAGE