

POWER CIRCUIT  
TRAVELLING POWER SUPPLY SYSTEM

ADDRESS NO.  
A1



-NOTE-

- 1. - - - - MARKED OWNER SCOPE
- 2. ———— MARKED CRANE MAKER SCOPE

TITLE MAIN POWER CIRCUIT DIAGRAM1				PROJECTION 	
WORK NO 601	WORK NAME DHDBM			SCALE 1/1	Q' TY 1
DRAWN LEE G.H. 2010.07.30		CHECKED	REVIEWED	APPROVED	DRAWING NO DHDBM
				CODE NO	
L K HOIST CO., LTD.					

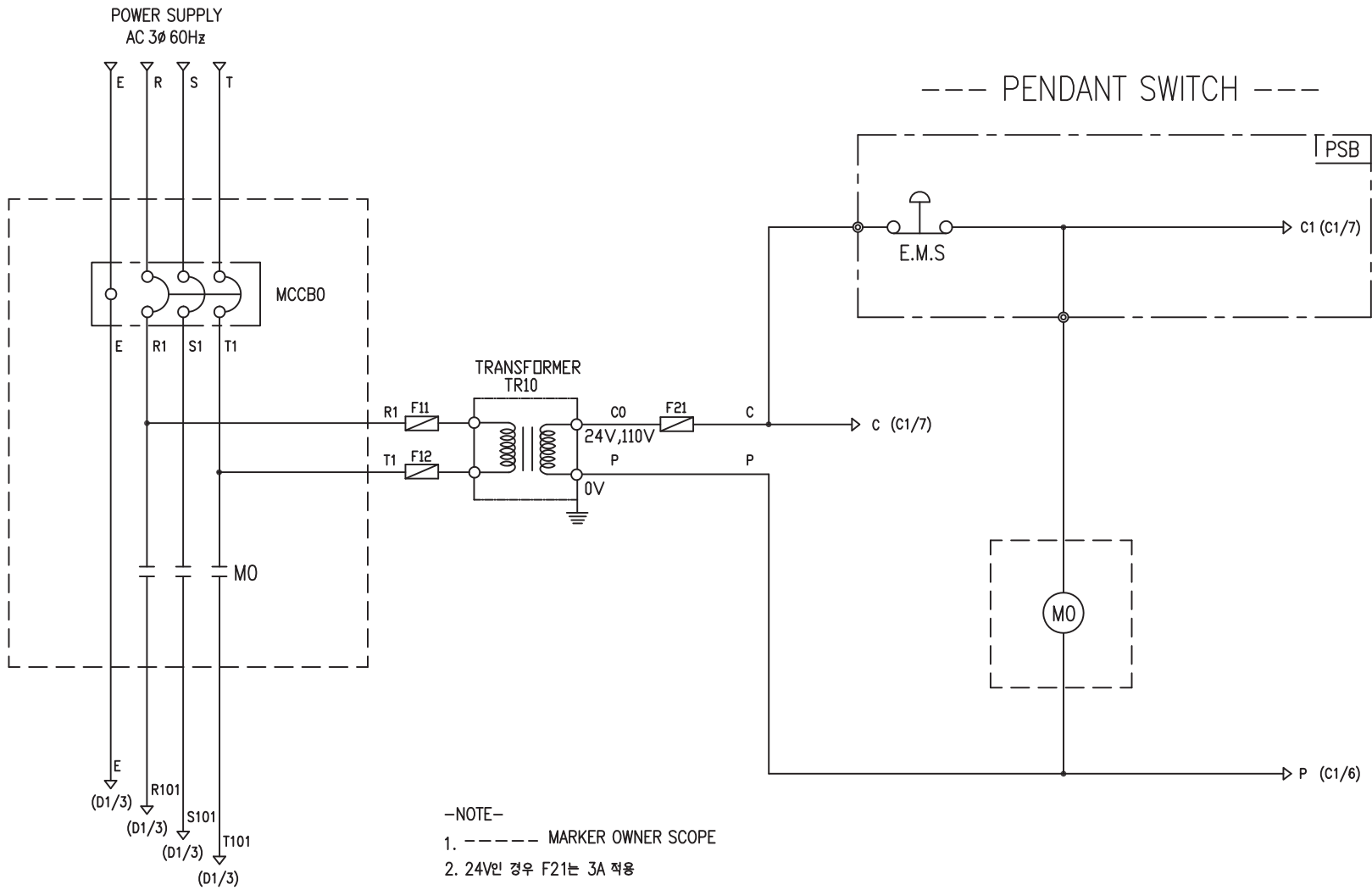

-NOTE-

1. ----- MARKER OWNER SCOPE
2. 24V인 경우 F21는 3A 적용

HOISTING & TRAVERSING POWER

SPECIFICATION	NO FUSE BREAKER	MAGNET CONTACT	TRANSFORMER	FUZE		
SYMBOLS	MCCB0	MO	TR10	F11, F12, F21		
DESCRIPTION	220V	50A	GMC22	DMC22	60VA	1A
	380V	30A				
	440V	30A				
	460V	30A				
480V	30A					
MAKER	LS	LS	DONGA	LK	-	

TITLE MAIN POWER & CONTROL CIRCUIT DIAGRAM						PROJECTION 	
WORK NO 602		WORK NAME DHDBM				SCALE 1/1	Q' TY 1
220V, 380V, 440V, 460V, 480V							
DRAWN LEE.G.H	CHECKED	REVIEWED	APPROVED	MODEL	DHDBM		
2010.07.30				CODE NO			
<b>L K HOIST CO., LTD.</b>							

HOIST POWER CIRCUIT

HOIST CONTROL CIRCUIT

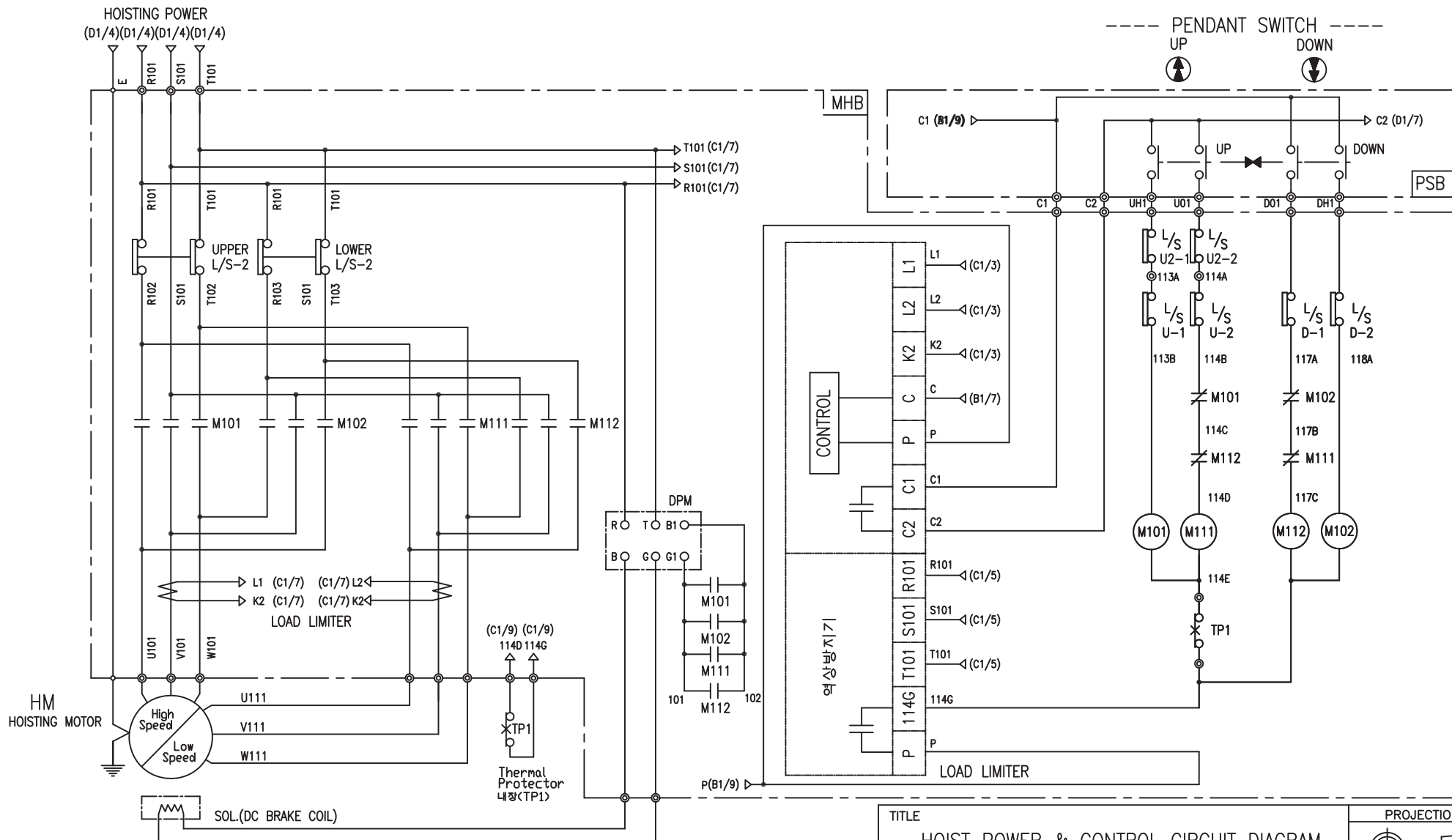

-NOTE-  
1. : Mechanical Interlock

SPECIFICATION	MAGNET CONTACT	LOAD LIMITER	SILICON RECTIFIER				Thermal Protector	HOIST MOTOR
			AC380V	AC440V	AC460V	AC480V		
SYMBOLS	M101, M102 M103, M104	-	DPM				TP1	HM
DESCRIPTION	DMC22	LKDL-601	DC171V	DC198V	DC207V	DC216V	17AM032	4.4Kw * 2P/2.2Kw*6P
MAKER	DONG-A	LK	LK				Texas Instruments	LK

TITLE HOIST POWER & CONTROL CIRCUIT DIAGRAM						PROJECTION 	
WORK NO 604		WORK NAME DHDBM				SCALE 1/1	Q' TY 1
DRAWN LEE.G.H	CHECKED	REVIEWED	APPROVED	MODEL DHDBM	CODE NO		
2010.07.30				L K HOIST CO., LTD.			

TRAVERSING POWER CIRCUIT

TRAVERSING CONTROL CIRCUIT

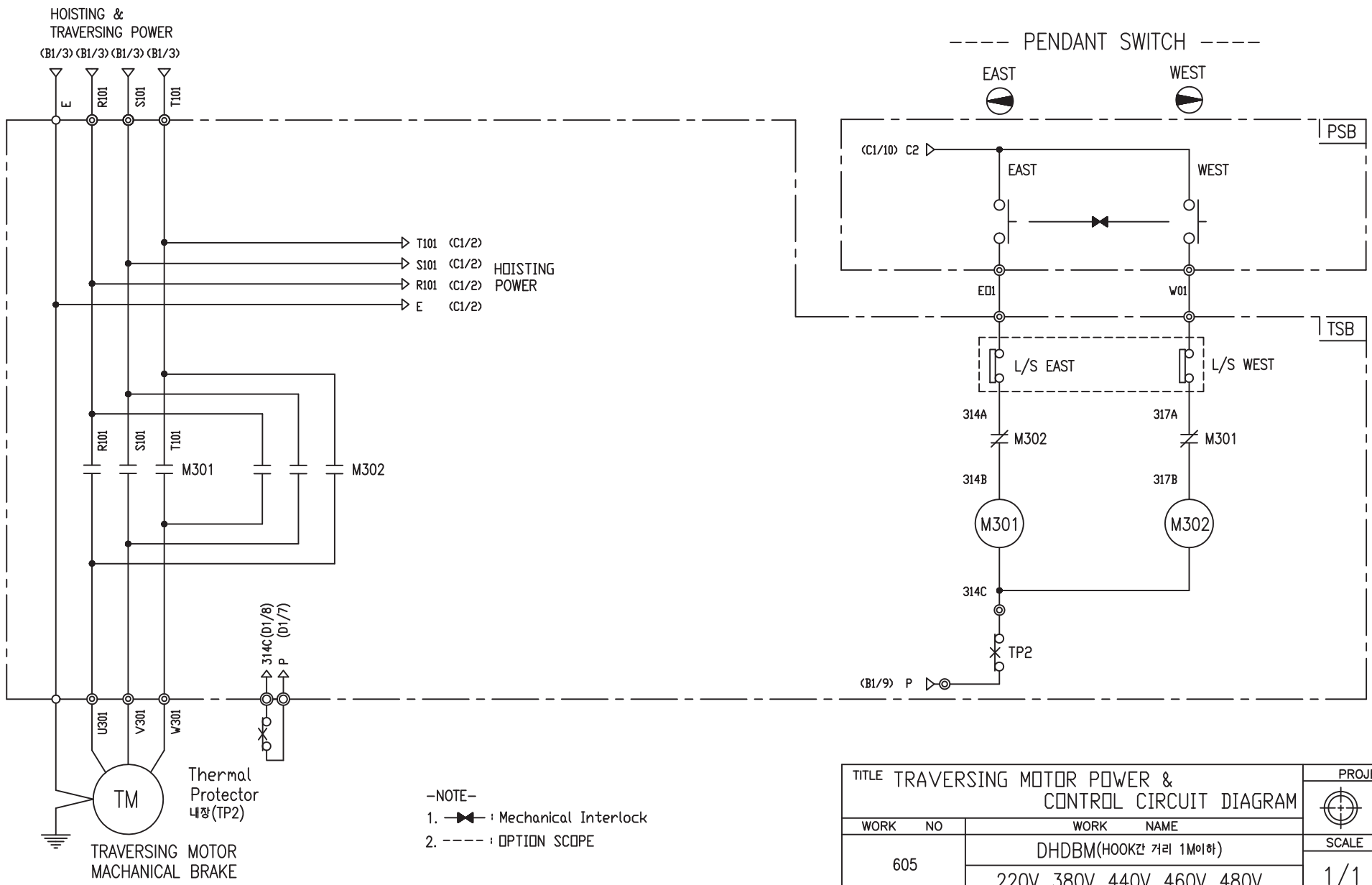

SPECIFICATION	MAGNET CONTACT	Thermal Protector	TRAVERSING MOTOR
SYMBOLS	M301, M302	TP2	TM
DESCRIPTION	GMC12 DMC12	17AM032	0.75KW *4P 0.4KW *6P
MAKER	LS DONGA	Texas Instruments	LK

TITLE TRAVERSING MOTOR POWER & CONTROL CIRCUIT DIAGRAM						PROJECTION	
WORK NO		WORK NAME					
605		DHDBM(HOOK간 거리 1M이하)				SCALE	Q' TY
		220V, 380V, 440V, 460V, 480V				1/1	1
DRAWN	CHECKED	REVIEWED	APPROVED	MODEL	DHDBM		
LEE.G.H				CODE NO			
2010.07.30							

TRAVERSING POWER CIRCUIT

TRAVERSING CONTROL CIRCUIT

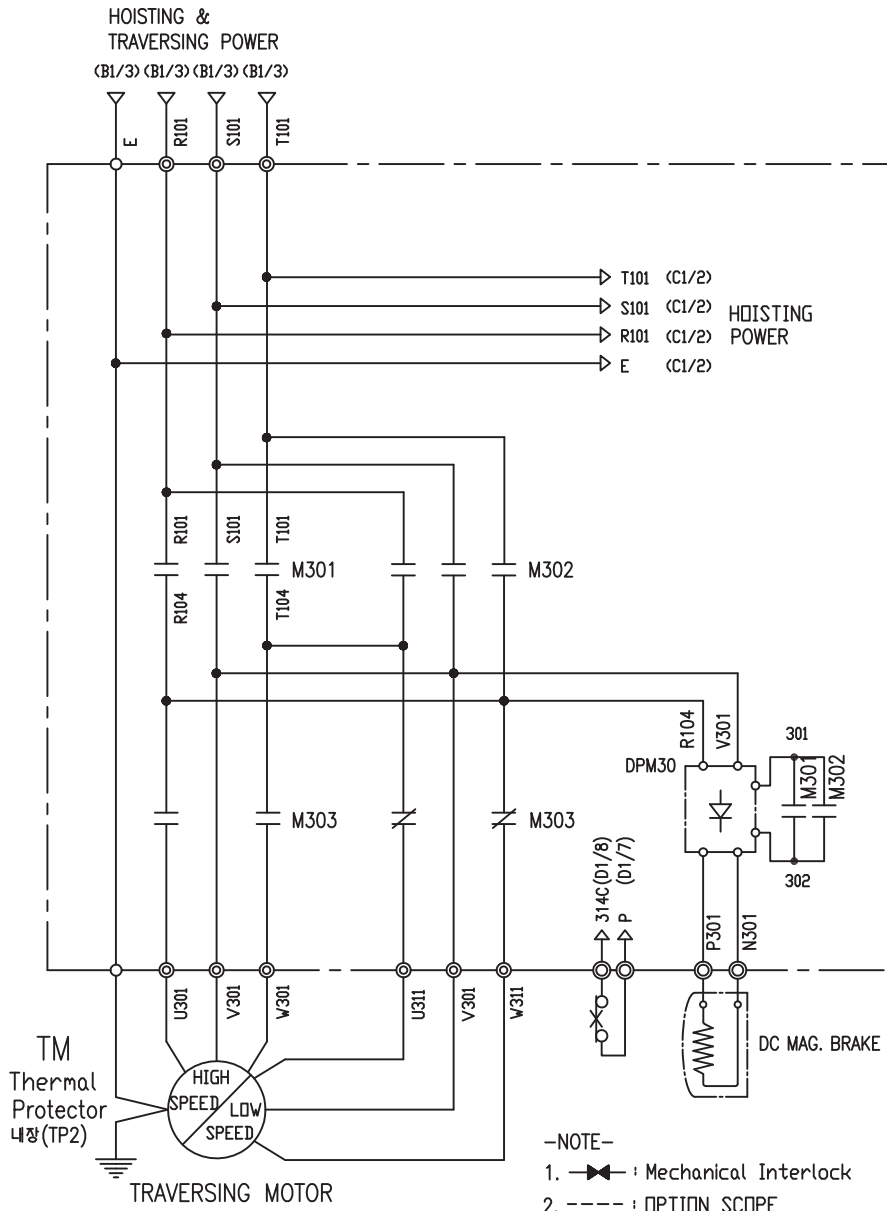

-NOTE-

1. —|> : Mechanical Interlock
2. - - - - : OPTION SCOPE

----- PENDANT SWITCH -----

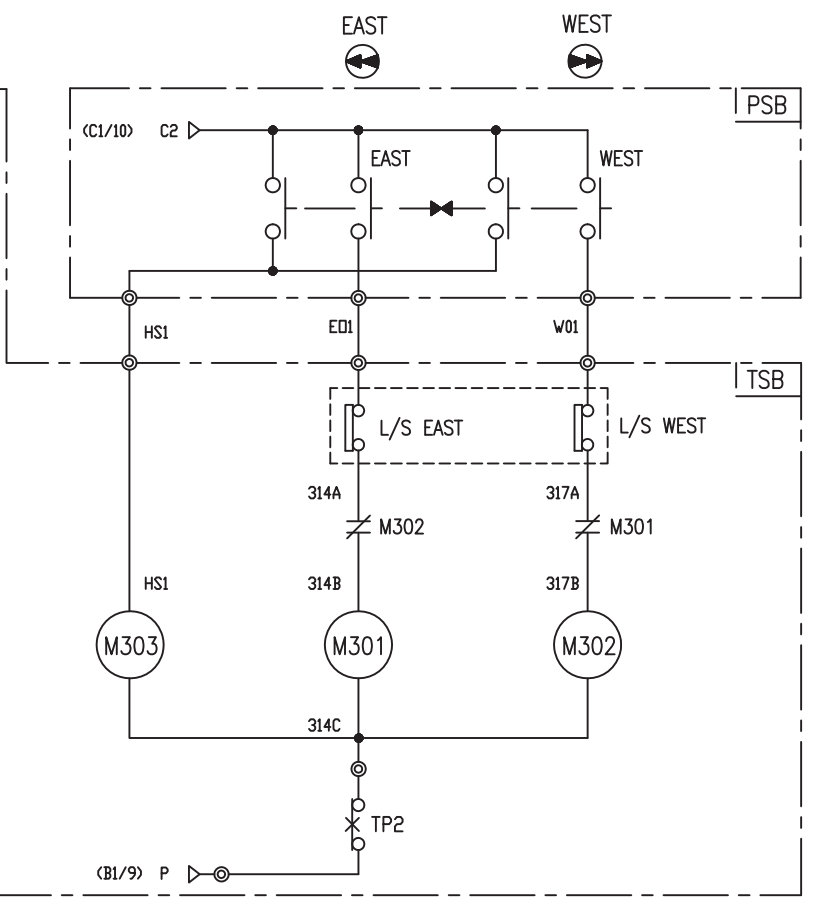

SPECIFICATION	MAGNET CONTACT	Thermal Protector	SILICON RECTIFIER					TRAVERSING MOTOR	
SYMBOLS	M301, M302, M303	TP2	DPM30					TM	
DESCRIPTION	GMC12	DMC12	17AM032	AC220V	AC380V	AC440V	AC460V	AC480V	0.75/0.25KW *4/12P
				DC99V	DC171V	DC198V	DC207V	DC216V	
MAKER	LS	DONGA	Texas Instruments	LK					LK

TITLE TRAVERSING MOTOR POWER & CONTROL CIRCUIT DIAGRAM						PROJECTION	
WORK NO		WORK NAME					
606		DHDBM(HOOK안 거리 1M이하)				SCALE	Q' TY
		220V, 380V, 440V, 460V, 480V				1/1	1
DRAWN	CHECKED	REVIEWED	APPROVED	MODEL	DBM		
LEE.G.H				CODE NO			
2010.07.30							
<b>L K HOIST CO., LTD.</b>							

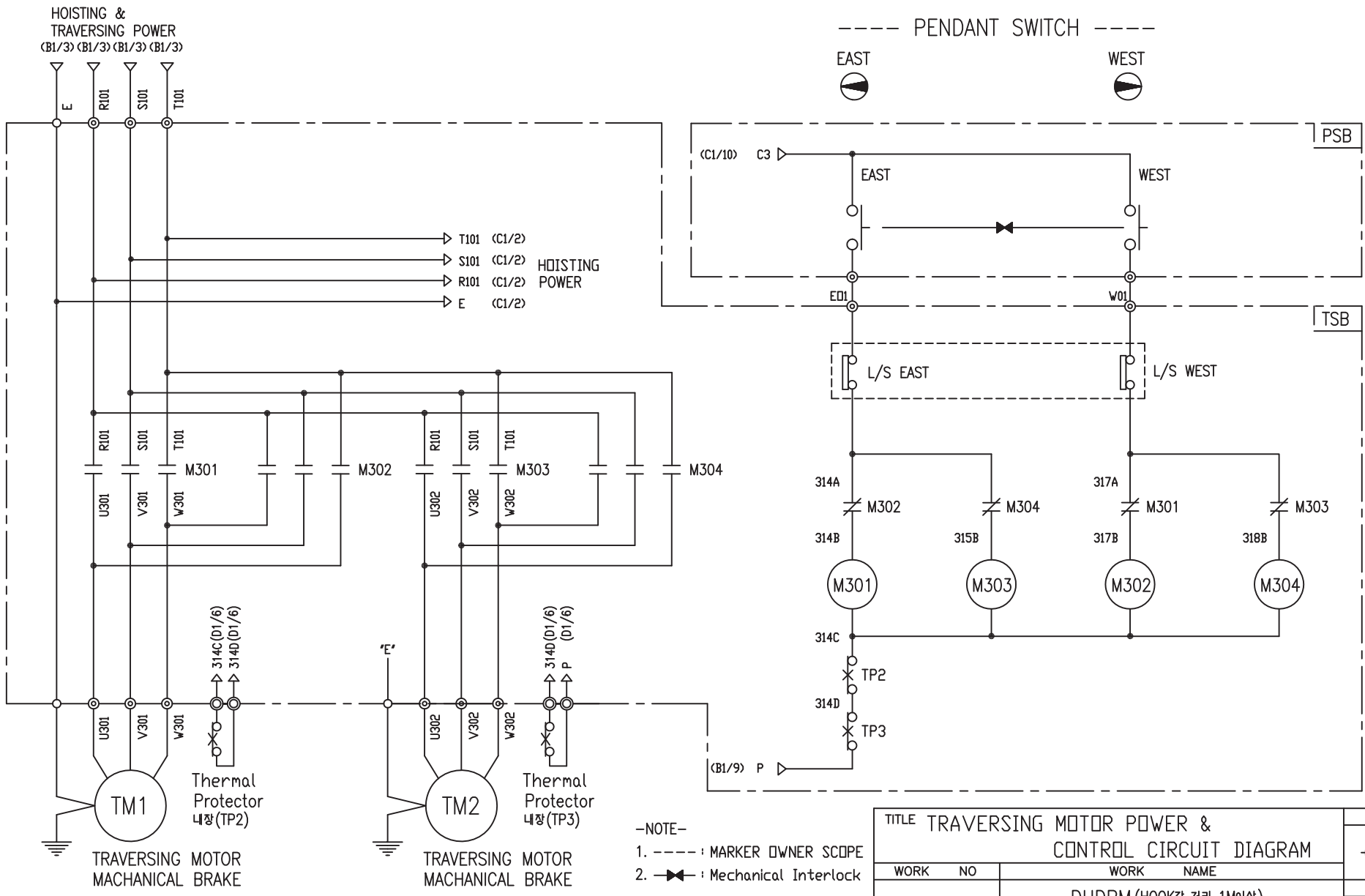

-NOTE-  
 1. ----- : MARKER OWNER SCOPE  
 2. —|—|— : Mechanical Interlock

TITLE TRAVERSING MOTOR POWER & CONTROL CIRCUIT DIAGRAM						PROJECTION	
WORK NO		WORK NAME					
607		DHDBM (HOOK간 거리 1M이상)				SCALE	Q' TY
		220V, 380V, 440V, 460V, 480V				1/1	1
DRAWN	CHECKED	REVIEWED	APPROVED	MODEL	DHDAM		
LEE.G.H				CODE NO			
2010.07.30							
<b>LK L K HOIST CO., LTD.</b>							

SPECIFICATION	MAGNET CONTACT	Thermal Protector	TRAVERSING MOTOR	
SYMBOLS	M301, M302, M303, M304	TP2, TP3	TM1, TM2	
DESCRIPTION	GMC12 DMC12	17AM032	0.75KW *4P(2set)	0.4KW *6P(2set)
MAKER	LS DONGA	Texas Instruments	LK	

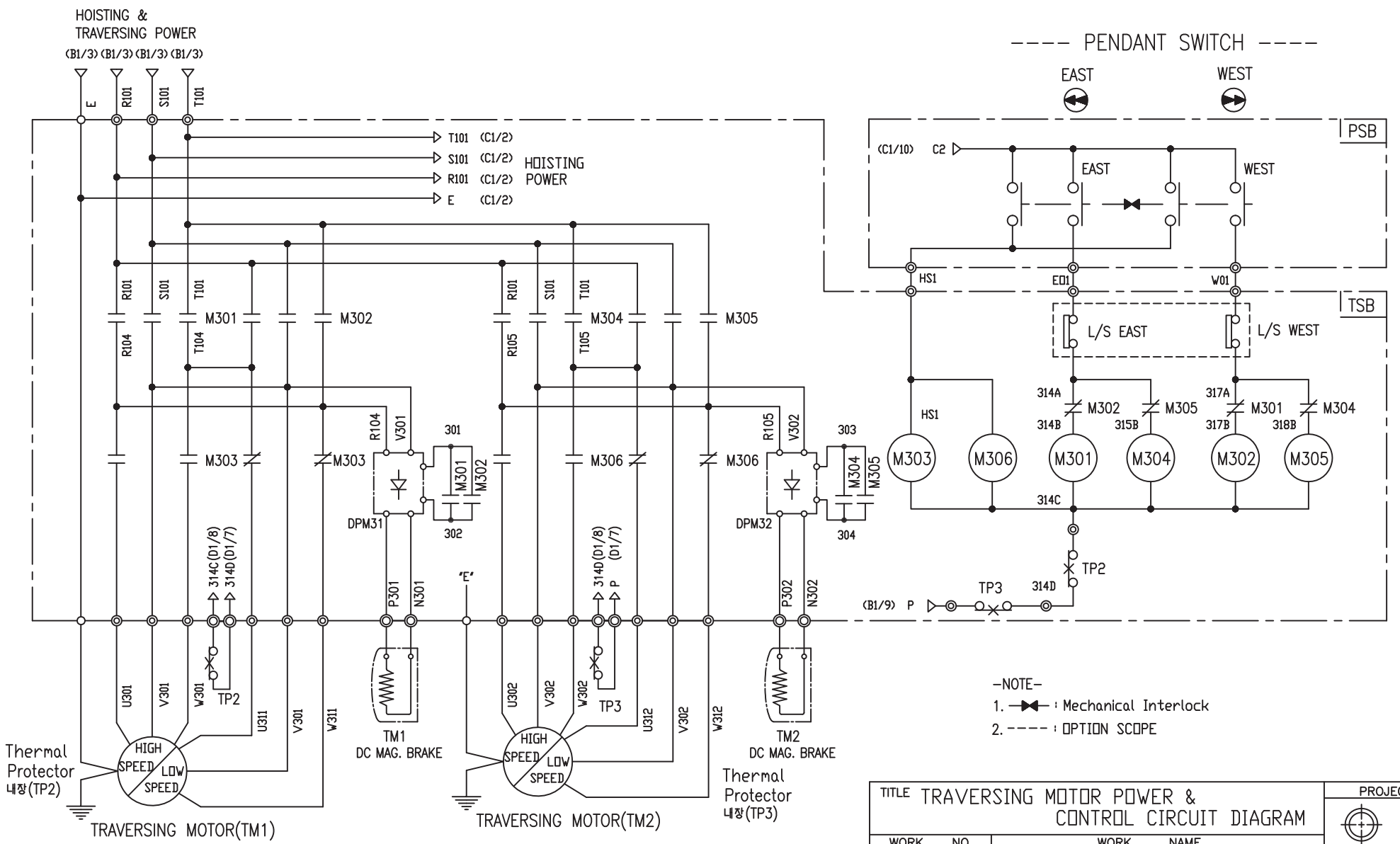

-NOTE-

1. ——— : Mechanical Interlock
2. - - - - : OPTION SCOPE

SPECIFICATION	MAGNET CONTACT	Thermal Protector	SILICON RECTIFIER			TRAVERSING MOTOR
SYMBOLS	M301, M302, M303 M304, M305, M306	TP2, TP3	DPM31, DPM32			TM1, TM2
DESCRIPTION	GMC12	DMC12	17AM032	AC220V	AC380V	0.75/0.25Kw *4/12P (2set)
				DC99V	DC171V	
MAKER	LS	DONGA	Texas Instruments			LK

TITLE TRAVERSING MOTOR POWER & CONTROL CIRCUIT DIAGRAM						PROJECTION	
WORK NO		WORK NAME				SCALE	
608		DHDBM (HOOK간 거리 1M이상)				1/1	
220V, 380V, 440V, 460V, 480V		DRAWN		CHECKED	REVIEWED	APPROVED	MODEL
2010.07.30		LEE.G.H					DHDAM
		CODE NO					
<b>L K HOIST CO., LTD.</b>							

## SCHEDULE OF TECHNICAL DATA

1. SERVICE	HOISTING
2. MANUFACTURE	LK HOIST CO. LTD
3. MOTOR MODEL NO	4.4/2.2 - 2/6 - 38
4. RATED POWER	4.4/2.2 KW × 2/6 P
5. RATED VOLTAGE AND FREQUENCY	380 V      60HZ
6. MOTOR TYPE	SQUIRREL CAGE ROTOR TYPE
7. RATING	30 MIN
8. LOCATION	OUTDOOR
9. INSULATION CLASS	B
10. DESIGN TEMPERATURE RISE (BY RESISTANCE)	80℃
11. FULL LOAD SPEED	3440/1140 RPM
12. FULL LOAD CURRENT	13/6.5 A
13. STARTING CURRENT AT RATED VOLTAGE	66/33.2 A
14. MINIMUM STARTING VOLTAGE	342 V
15. EFFICIENCY AT 100% RATED LOAD	73/73 %
16. POWER FACTOR AT 100% RATED LOAD	71/71 %
17. STARTING TORQUE	242 %
18. TYPE OF ENCLOSURE	전폐형
19. TYPE OF BEARING	PL : 6205DD    OPL : 6008ZZ
20. MOUNTING	VERTICAL
21. MAXIMUM AMBIENT TEMPURE	40℃
22. BEARING LUBRICATION	GREASE
23. STARTING METHOD	FULL VOLTAGE

## SCHEDULE OF TECHNICAL DATA

1. SERVICE	TRAVERSING
2. MANUFACTURE	LK HOIST CO. LTD
3. MOTOR MODEL NO	0.75 - 4 - 38
4. RATED POWER	0.75 KW × 4 P
5. RATED VOLTAGE AND FREQUENCY	380 V      60HZ
6. MOTOR TYPE	SQUIRREL CAGE ROTOR TYPE
7. RATING	15 MIN
8. LOCATION	OUTDOOR
9. INSULATION CLASS	B
10. DESIGN TEMPERATURE RISE (BY RESISTANCE)	100℃
11. FULL LOAD SPEED	1670 RPM
12. FULL LOAD CURRENT	2.77 A
13. STARTING CURRENT AT RATED VOLTAGE	15.2 A
14. MINIMUM STARTING VOLTAGE	342 V
15. EFFICIENCY AT 100% RATED LOAD	65 %
16. POWER FACTOR AT 100% RATED LOAD	63 %
17. STARTING TORQUE	250 %
18. TYPE OF ENCLOSURE	전폐형
19. TYPE OF BEARING	PL : 6008DD    OPL : 6207ZZ
20. MOUNTING	VERTICAL
21. MAXIMUM AMBIENT TEMPURE	40℃
22. BEARING LUBRICATION	GREASE
23. STARTING METHOD	FULL VOLTAGE

## SCHEDULE OF TECHNICAL DATA

1. SERVICE	TRAVERSING
2. MANUFACTURE	LK HOIST CO. LTD
3. MOTOR MODEL NO	0.4 - 6 - 38
4. RATED POWER	0.4 KW × 6 P
5. RATED VOLTAGE AND FREQUENCY	380 V      60HZ
6. ROTOR TYPE	SQUIRREL CAGE ROTOR TYPE
7. RATING	15 MIN
8. LOCATION	OUTDOOR
9. INSULATION CLASS	B
10. DESIGN TEMPERATURE RISE (BY RESISTANCE)	100℃
11. FULL LOAD SPEED	1140 RPM
12. FULL LOAD CURRENT	1.85 A
13. STARTING CURRENT AT RATED VOLTAGE	10.5 A
14. MINIMUM STARTING VOLTAGE	342 V
15. EFFICIENCY AT 100% RATED LOAD	65 %
16. POWER FACTOR AT 100% RATED LOAD	63 %
17. STARTING TORQUE	249 %
18. TYPE OF ENCLOSURE	전폐형
19. TYPE OF BEARING	PL : 6008DD    OPL : 6207ZZ
20. MOUNTING	VERTICAL
21. MAXIMUM AMBIENT TEMPERATURE	40℃
22. BEARING LUBRICATION	GREASE
23. STARTING METHOD	FULL VOLTAGE

## SCHEDULE OF TECHNICAL DATA

1. SERVICE	TRAVERSING
2. MANUFACTURE	LK HOIST CO. LTD
3. MOTOR MODEL NO	0.75/0.25 - 4/12 - 38
4. RATED POWER	0.75/0.25 KW × 4/12 P
5. RATED VOLTAGE AND FREQUENCY	380 V 60HZ
6. MOTOR TYPE	SQUIRREL CAGE ROTOR TYPE
7. RATING	15 MIN
8. LOCATION	OUTDOOR
9. INSULATION CLASS	B
10. DESIGN TEMPERATURE RISE (BY RESISTANCE)	100℃
11. FULL LOAD SPEED	1670 / 550 RPM
12. FULL LOAD CURRENT	2.77 / 1.74 A
13. STARTING CURRENT AT RATED VOLTAGE	15.3 / 9.57 A
14. MINIMUM STARTING VOLTAGE	342 V
15. EFFICIENCY AT 100% RATED LOAD	65 / 48 %
16. POWER FACTOR AT 100% RATED LOAD	63 / 46 %
17. STARTING TORQUE	249/ 245 %
18. TYPE OF ENCLOSURE	전폐형
19. TYPE OF BEARING	PL : 6008DD OPL : 6207ZZ
20. MOUNTING	VERTICAL
21. MAXIMUM AMBIENT TEMPURE	40℃
22. BEARING LUBRICATION	GREASE
23. STARTING METHOD	FULL VOLTAGE