

ON OMD

# L K HOIST

NO	DESCRIPTION	SIZE	MAT' L	Q' TY	WT (kg)	REMARKS
----	-------------	------	--------	-------	---------	---------

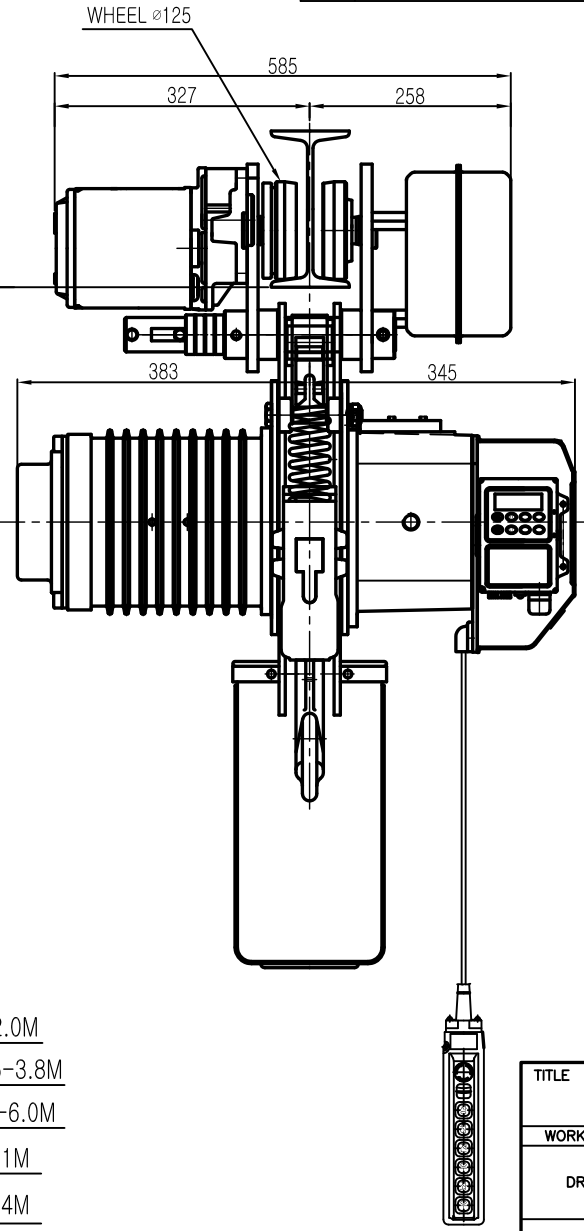
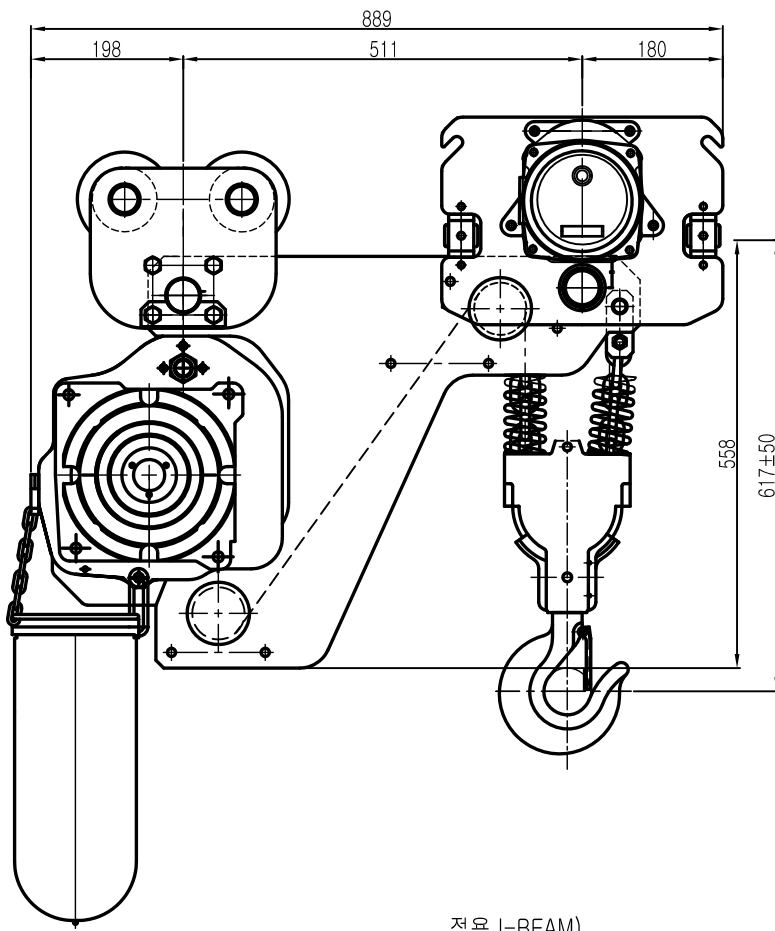

## SPECIFICATION

		LK-SHDBM-2.8W		
RATED LOAD	(TON)	2.8		
TESTING LOAD	(TON)	3.5		
LIFTING HEIGHT	(M)	50		
HOISTING	SPEED (M/MIN)	5.15/1.7		
	MOTOR (KW)	4.4/2.2kw x 2/6p		
TRAVERSING	SPEED (M/MIN)	20	14	20/7
	MOTOR (KW)	0.75kw x 4p	0.4kw x 6p	0.75/0.25kw x 4/12p
POWER SUPPLY	AC220.380.440.460.480Vx3ø x 60 Hz			
OPERATING METHOD	P.B type ON . FL			
LOAD CHAIN	ø9.5 X 28.6 (2FALL)			
WEIGHT	(KG)	502		
I-BEAM 적용폭	100 ~ 190MM			

### NOTE)

- 1)점검 설비를 갖출 것
- 2)인허가 서류를 완성검사시 제출 할 것

### 적용 I-BEAM)

- 1) 지점간 거리: I-200X100X7/10 - 2.0M
- 2) 지점간거리 : I-250X125X7.5/12.5-3.8M
- 3) 지점간거리 : I-300X150X10/18.5-6.0M
- 4) 지점간거리 : I-450X175X13/26-11M
- 5) 지점간거리 : I-600X190X13/25-14M

REV.NO	DATE	REVISION	DESCRIPTION	DRAWN	CHECKED	APPROVED
--------	------	----------	-------------	-------	---------	----------

TITLE		ELECTRIC CHAIN HOIST			PROJECTION	
WORK NO		WORK NAME				
DRAWN		LK-SHDBM-2.8W			SCALE	Q' TY
					N S	1
CHECKED	REVIEWED	APPROVED	DRAWING NO			
김 창 기			CORD NO			
2010.08.01						

ON 5MG

# L K HOIST

NO	DESCRIPTION	SIZE	MAT L	Q' TY	WT (kg)	REMARKS
----	-------------	------	-------	-------	---------	---------

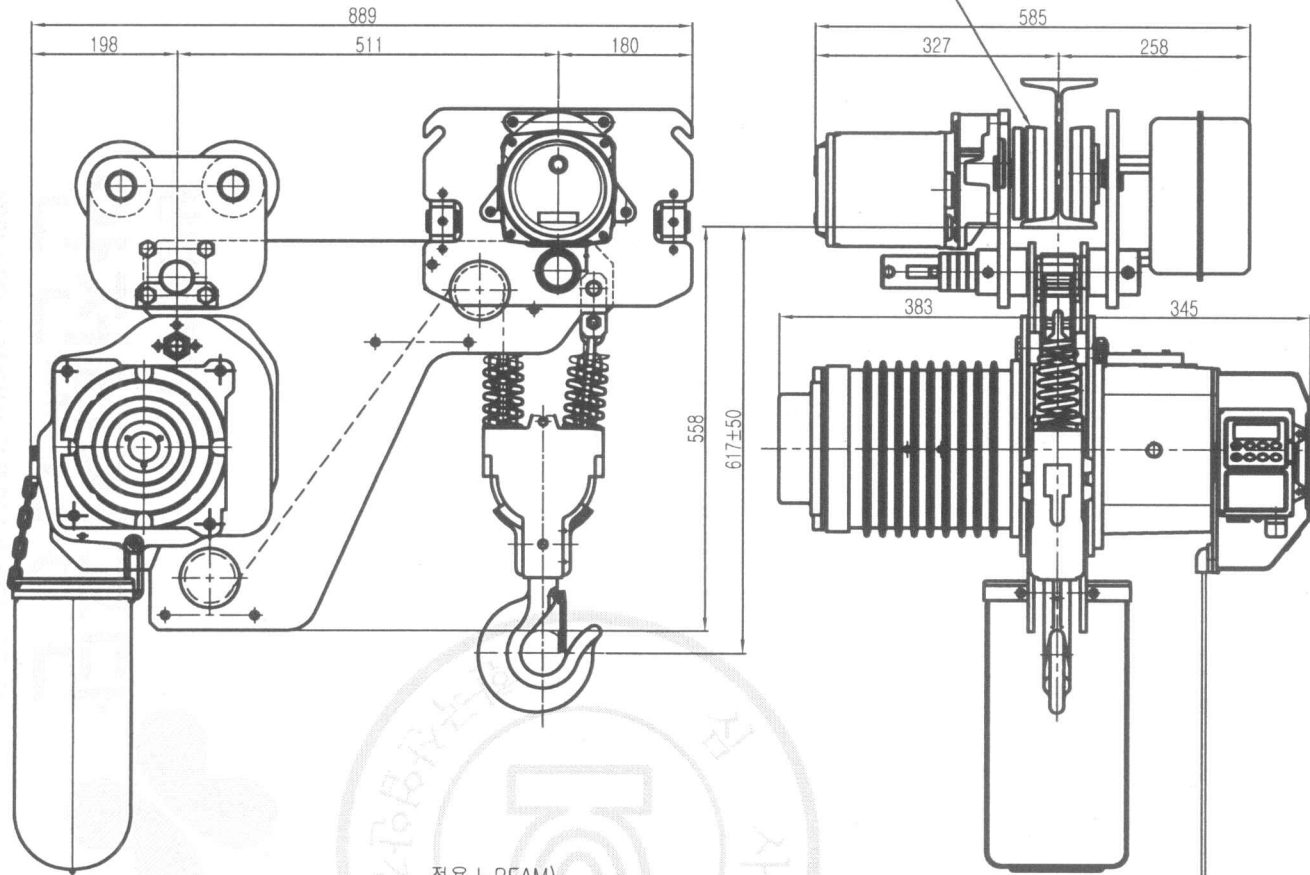

## SPECIFICATION

		LK-SHDBM-2.8W		
RATED LOAD (TON)		2.8		
TESTING LOAD (TON)		3.5		
LIFTING HEIGHT (M)		50		
HOISTING	SPEED (M/MIN)	5.15/1.7		
	MOTOR (KW)	4.4/2.2kw x 2/6p		
TRAVERSING	SPEED (M/MIN)	20	14	20/7
	MOTOR (KW)	0.75kw x 4p	0.4kw x 6p	0.75/0.25kw x 4/12p
POWER SUPPLY		AC220.380.440.460.480Vx3ø x 60 Hz		
OPERATING METHOD		P.B type ON, FL		
LOAD CHAIN		ø9.5 X 28.6 (2FALL)		
WEIGHT (KG)		502		
I-BEAM 적용폭		100 ~ 190MM		

### NOTE)

- 1)점검 설비를 갖출 것
- 2)인허가 서류를 완성검사시 제출할 것

적용 I-BEAM)

- 1) 지점간 거리: I-200X100X7/10 - 2.0M
- 2) 지점간거리 : I-250X125X7.5/12.5-3.8M
- 3) 지점간거리 : I-300X150X10/18.5-6.0M
- 4) 지점간거리 : I-450X175X13/26-11M
- 5) 지점간거리 : I-600X190X13/25-14M

REV.NO	DATE	REVISION	DESCRIPTION	DRAWN	CHECKED	APPROVED
--------	------	----------	-------------	-------	---------	----------

TITLE				PROJECTION	
ELECTRIC CHAIN HOIST					
WORK NO	WORK NAME			SCALE	Q' TY
	LK-SHDBM-2.8W			N S	1
DRAWN	CHECKED	REVIEWED	APPROVED	DRAWING NO	
김창기				CORD NO	
2010.08.01					
L K HOIST CO., LTD.					

물범복제 및 배포금지