

ON 5MD

# L K HOIST

NO	DESCRIPTION	SIZE	MAT' L	Q' TY	WT (kg)	REMARKS

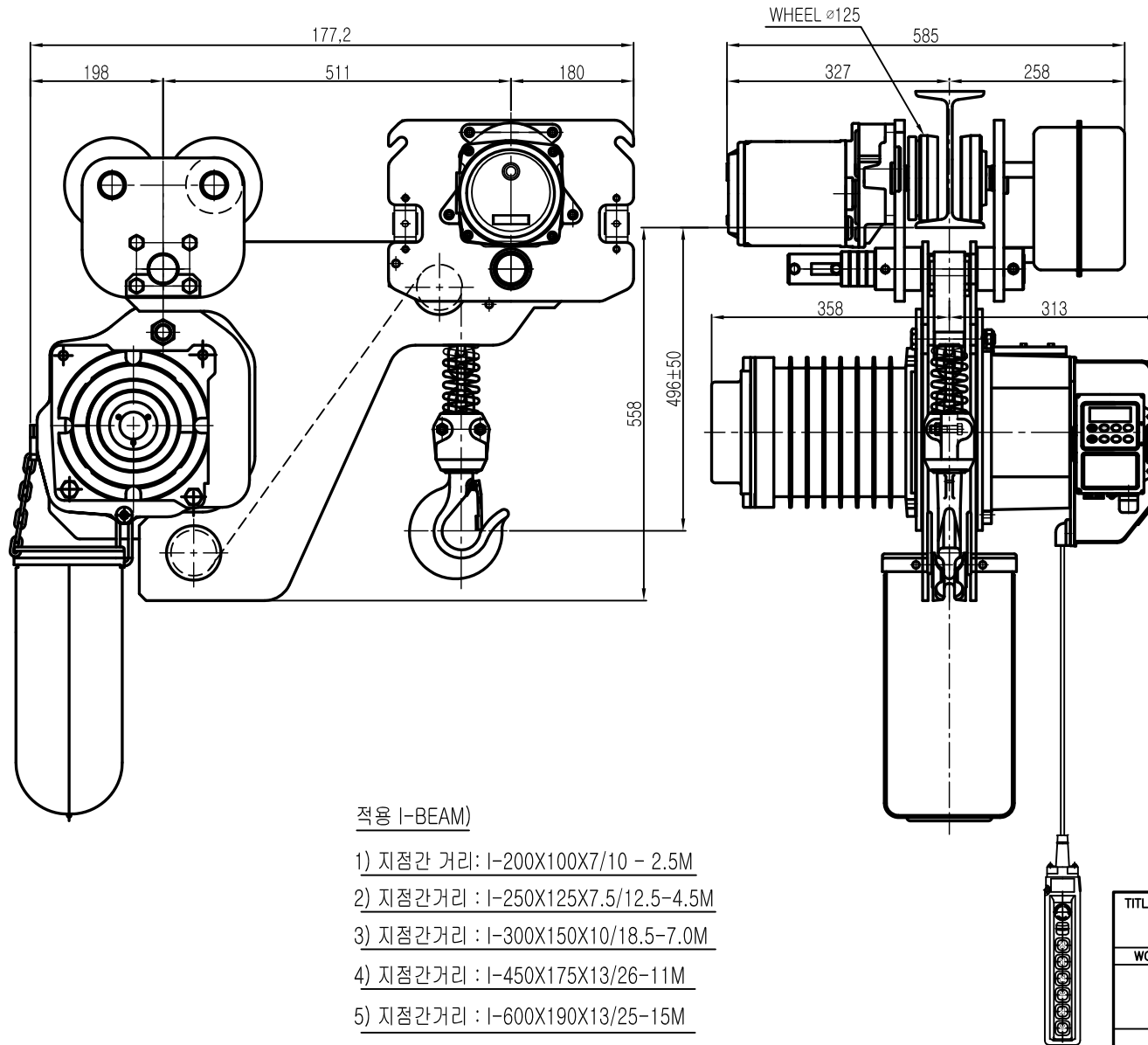

## SPECIFICATION

		LK-SHDAM-2.5S		
RATED LOAD	(TON)	2.5		
TESTING LOAD	(TON)	3.125		
LIFTING HEIGHT	(M)	50		
HOISTING	SPEED (M/MIN)	6.5		
	MOTOR (KW)	3.5kw x 4p		
TRAVERSING	SPEED (M/MIN)	20	14	20/7
	MOTOR (KW)	0.75kw x 4p	0.4kw x 6p	0.75/0.25kw x 4/12p
POWER SUPPLY	AC220.380.440.460.480Vx3ø x 60 Hz			
OPERATING METHOD	P.B type ON . FL			
LOAD CHAIN	ø11.2 X 34 (1FALL)			
WEIGHT	(KG)	370		
I-BEAM 적용폭	100 ~ 190MM			

### NOTE)

- 1)점검 설비를 갖출 것
- 2)인허가 서류를 완성검사시 제출 할 것

적용 I-BEAM)

- 1) 지점간 거리: I-200X100X7/10 - 2.5M
- 2) 지점간거리 : I-250X125X7.5/12.5-4.5M
- 3) 지점간거리 : I-300X150X10/18.5-7.0M
- 4) 지점간거리 : I-450X175X13/26-11M
- 5) 지점간거리 : I-600X190X13/25-15M

REV.NO	DATE	REVISION	DESCRIPTION	DRAWN	CHECKED	APPROVED

TITLE		ELECTRIC CHAIN HOIST			PROJECTION	
WORK NO	WORK NAME			SCALE	Q' TY	
DRAWN	LK-SHDAM-2.5S					
김창기	CHECKED	REVIEWED	APPROVED	DRAWING NO		
2010.08.01				CORD NO		
L K HOIST CO., LTD.						

ON GMD

# L K HOIST

NO	DESCRIPTION	SIZE	MAT L	Q' TY	WT (kg)	REMARKS

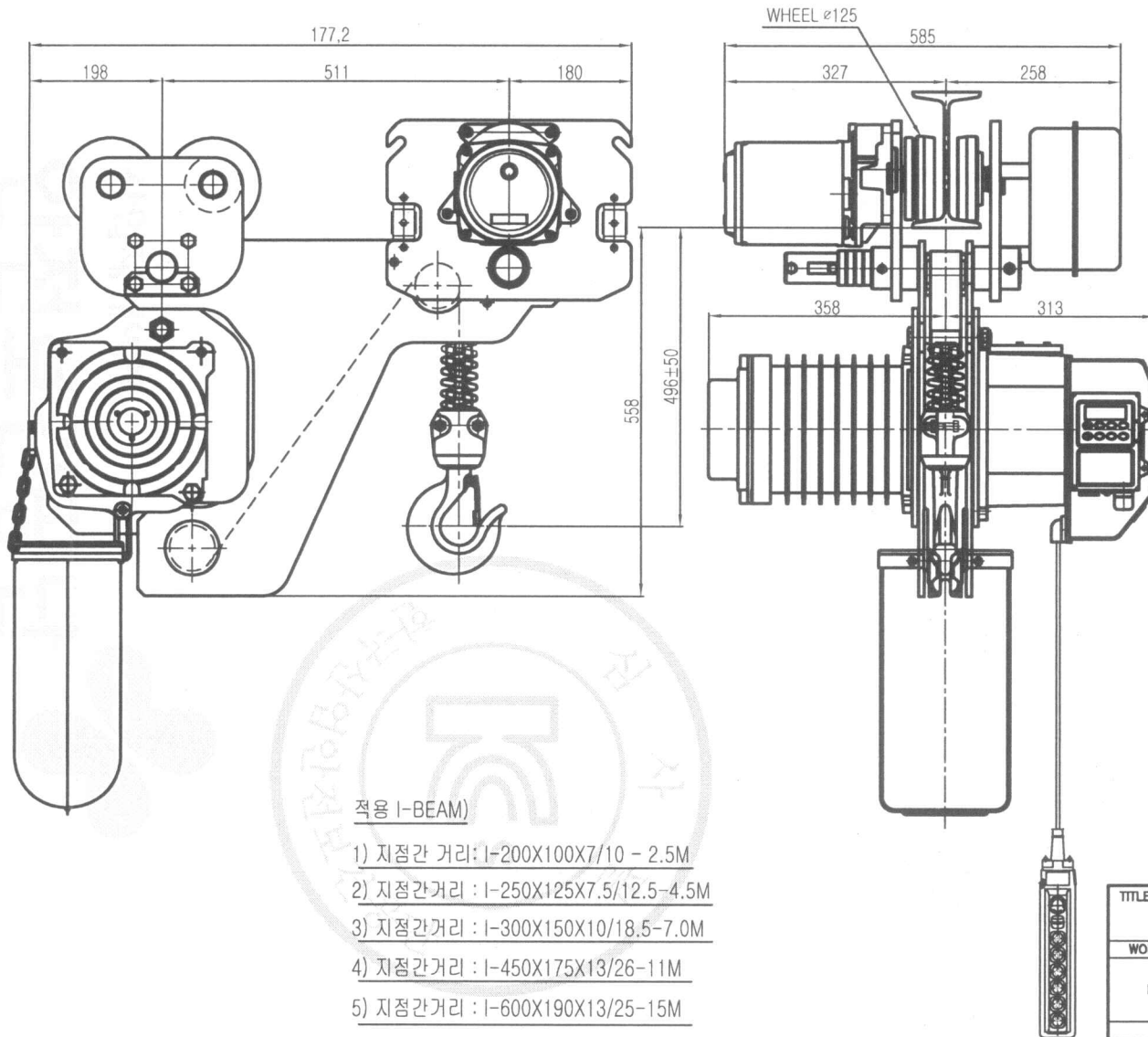

## SPECIFICATION

		LK-SHDAM-2.5S		
RATED LOAD (TON)		2.5		
TESTING LOAD (TON)		3.125		
LIFTING HEIGHT (M)		50		
HOISTING	SPEED (M/MIN)	6.5		
	MOTOR (KW)	3.5kw x 4p		
TRAVERSING	SPEED (M/MIN)	20	14	20/7
	MOTOR (KW)	0.75kw x 4p	0.4kw x 6p	0.75/0.25kw x 4/12p
POWER SUPPLY		AC220.380.440.460.480Vx3ø x 60 Hz		
OPERATING METHOD		P.B type ON . FL		
LOAD CHAIN		ø11.2 X 34 (1FALL)		
WEIGHT (KG)		370		
I-BEAM 적용폭		100 ~ 190MM		

### NOTE

- 1) 점검 설비를 갖출 것
- 2) 인허가 서류를 완성검사시 제출 할 것

적용 I-BEAM)

- 1) 지점간 거리: I-200X100X7/10 - 2.5M
- 2) 지점간거리 : I-250X125X7.5/12.5-4.5M
- 3) 지점간거리 : I-300X150X10/18.5-7.0M
- 4) 지점간거리 : I-450X175X13/26-11M
- 5) 지점간거리 : I-600X190X13/25-15M

REV.NO	DATE	REVISION	DESCRIPTION	DRAWN	CHECKED	APPROVED

TITLE				PROJECTION	
ELECTRIC CHAIN HOIST					
WORK NO	WORK NAME			SCALE	Q' TY
	LK-SHDAM-2.5S			N S	1
DRAWN	CHECKED	REVIEWED	APPROVED	DRAWING NO	CORD NO
김창기					
2010.08.01					
L K HOIST CO., LTD.					

물범복제 및 배포금지