

SPECIFICATION	NO FUSE BREAKER	MAGNET CONTACT	TRANSFORMER	FUZE		
SYMBOLS	MCCBO	M0	TR10	F11, F12, F21		
DESCRIPTION	220V	30A	GMC22	DMC-22	60VA	1A
	380V	20A				
	440V	20A				
	460V	20A				
	480V	20A				
MAKER	LS	LS	DONGA	YEONG DONG	-	

TITLE MAIN POWER & CONTROL CIRCUIT DIAGRAM						PROJECTION	
WORK NO		WORK NAME				SCALE	
601		DA				Q' TY	
220V, 380V, 440V, 460V, 480V		N/S		1			
DRAWN	CHECKED	REVIEWED	APPROVED	MODEL	DA		
LEE.G.H				CODE NO			
2010.07.30							
L K HOIST CO., LTD.							

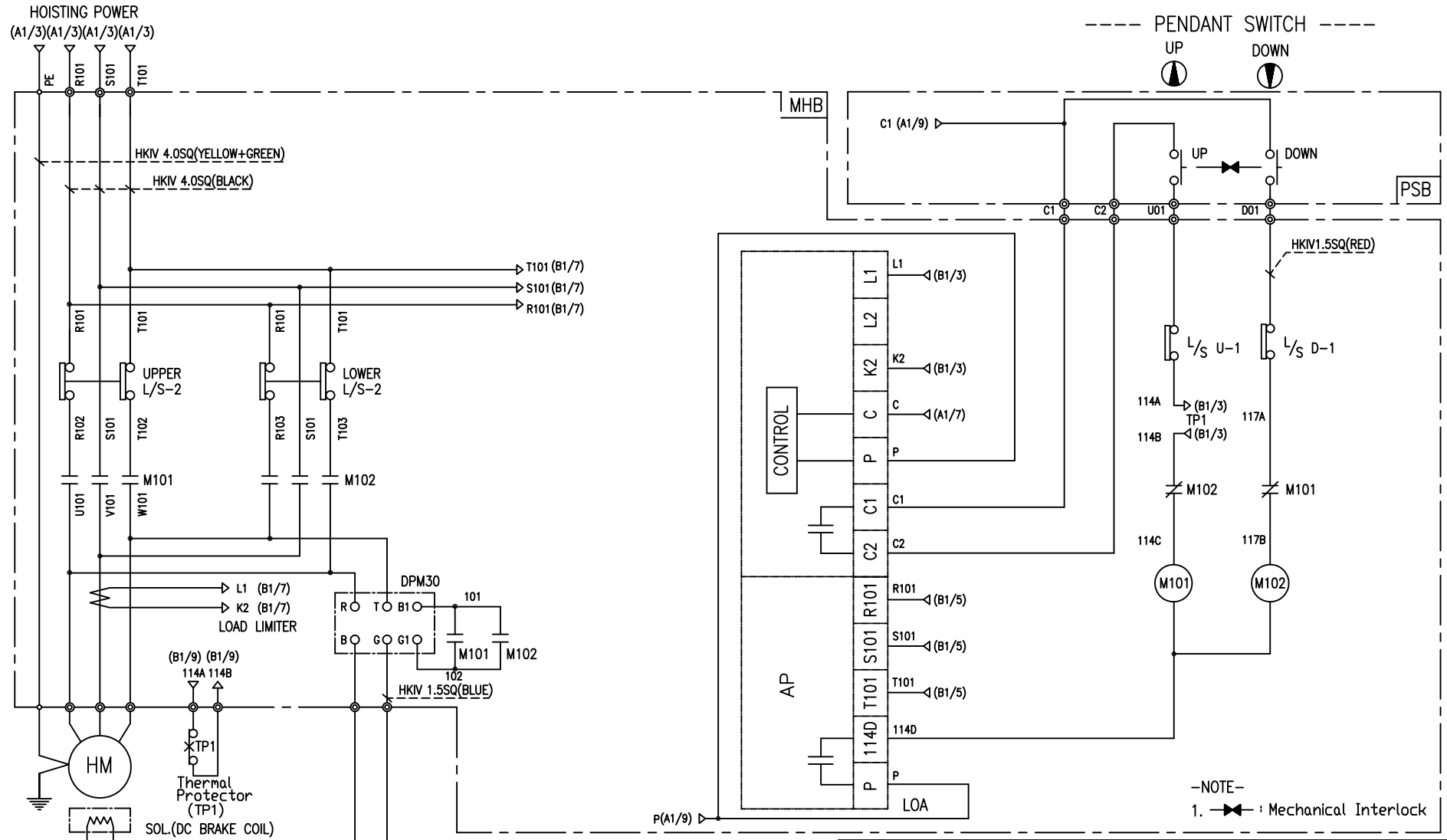

-NOTE-
 1. ——— : Mechanical Interlock

SPECIFICATION	MAGNET CONTACT	LOAD LIMITER	SILICON RECTIFIER				Thermal Protector	HOIST MOTOR
SYMBOLS	M101, M102	LOA	DPM30				TP1	HM
DESCRIPTION	DMC-22	LKDL-60A	AC220V	AC440V	AC460V	AC480V	17AM032	3.5Kw * 4P
			DC99V	DC198V	DC207V	DC216V		
MAKER	DONG-A	YANG YEONG	YANG YEONG				Texas Instruments	LK

TITLE HOIST POWER & CONTROL CIRCUIT DIAGRAM						PROJECTION 	
WORK NO 602		WORK NAME DA				SCALE N/S	Q' TY 1
DRAWN LEE.G.H		CHECKED	REVIEWED	APPROVED	MODEL DA		
2010.07.30						CODE NO	
L K HOIST CO., LTD.							

SCHEDULE OF TECHNICAL DATA

1. SERVICE	HOISTING
2. MANUFACTURE	LK HOIST CO. LTD
3. MOTOR MODEL NO	3.5 - 4 - 44
4. RATED POWER	3.5 KW × 4 P
5. RATED VOLTAGE AND FREQUENCY	440 V 60HZ
6. MOTOR TYPE	SQUIRREL CAGE ROTOR TYPE
7. RATING	30 MIN
8. LOCATION	IN-DOOR , OUTDOOR
9. INSULATION CLASS	B
10. DESIGN TEMPERATURE RISE (BY RESISTANCE)	80℃
11. FULL LOAD SPEED	1740 RPM
12. FULL LOAD CURRENT	8.6 A
13. STARTING CURRENT AT RATED VOLTAGE	46.4 A
14. MINIMUM STARTING VOLTAGE	396 V
15. EFFICIENCY AT 100% RATED LOAD	73.3 %
16. POWER FACTOR AT 100% RATED LOAD	72.8 %
17. STARTING TORQUE	245 %
18. TYPE OF ENCLOSURE	전폐형(IP-54)
19. TYPE OF BEARING	PL : 6205DD OPL : 6008ZZ
20. MOUNTING	VERTICAL
21. MAXIMUM AMBIENT TEMPURE	40℃
22. BEARING LUBRICATION	GREASE
23. STARTING METHOD	FULL VOLTAGE