

ON 9MG

# L K HOIST

NO	DESCRIPTION	SIZE	MAT'L	Q'TY	WT (kg)	REMARKS

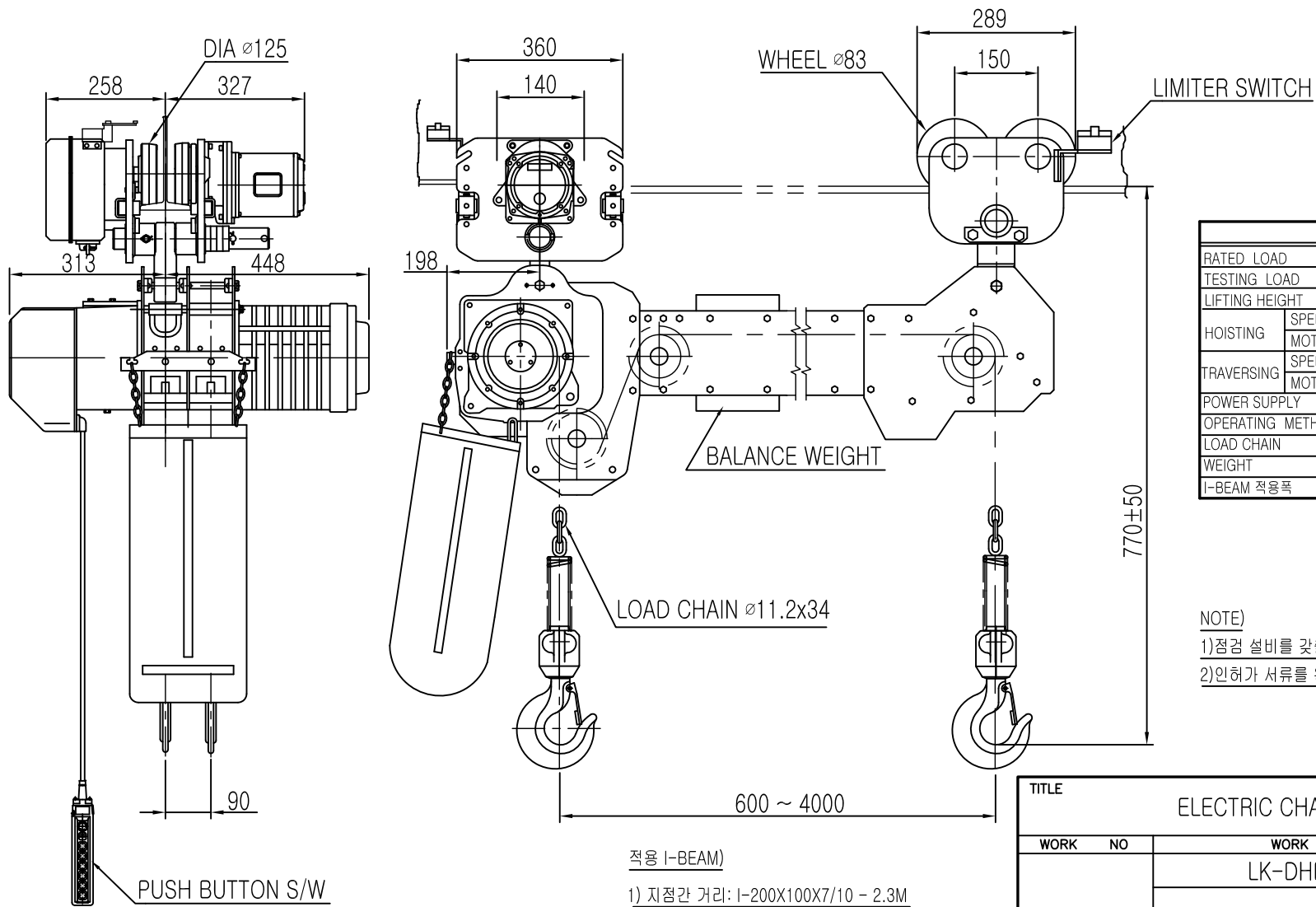

## SPECIFICATION

		LK-DHDAM-2.5S	
RATED LOAD (TON)		2.5	
TESTING LOAD (TON)		3.125	
LIFTING HEIGHT (M)		50	
HOISTING	SPEED (M/MIN)	6.5	
	MOTOR (KW)	3.5kw x 4p	
TRAVERSING	SPEED (M/MIN)	20	14
	MOTOR (KW)	0.75kw x 4p	0.4kw x 6p
POWER SUPPLY		AC220.380.440.460.480Vx3 $\phi$ x 60 Hz	
OPERATING METHOD		P.B type ON . FL	
LOAD CHAIN		$\phi 11.2 \times 34$ (1FALL)	
WEIGHT (KG)		655	
I-BEAM 적용폭		100 ~ 190MM	

NOTE)

- 1)점검 설비를 갖출 것
- 2)인허가 서류를 완성검사시 제출 할 것

적용 I-BEAM)

- 1) 지점간 거리: I-200X100X7/10 - 2.3M
- 2) 지점간거리 : I-250X125X7.5/12.5-4.0M
- 3) 지점간거리 : I-300X150X10/18.5-6.0M
- 4) 지점간거리 : I-450X175X13/26-10M
- 5) 지점간거리 : I-600X190X13/25-14M

TITLE				ELECTRIC CHAIN HOIST		PROJECTION	
WORK NO		WORK NAME	LK-DHDAM-2.5S			SCALE	Q'TY
					N S	1	
DRAWN	CHECKED	REVIEWED	APPROVED	DRAWING NO			
김 창 기				CORD NO			
2010.08.01							

REV.NO	DATE	REVISION	DESCRIPTION	DRAWN	CHECKED	APPROVED



L K HOIST CO., LTD.

ON ㉔MD

# L K HOIST

NO	DESCRIPTION	SIZE	MAT' L	Q' TY	WT (kg)	REMARKS

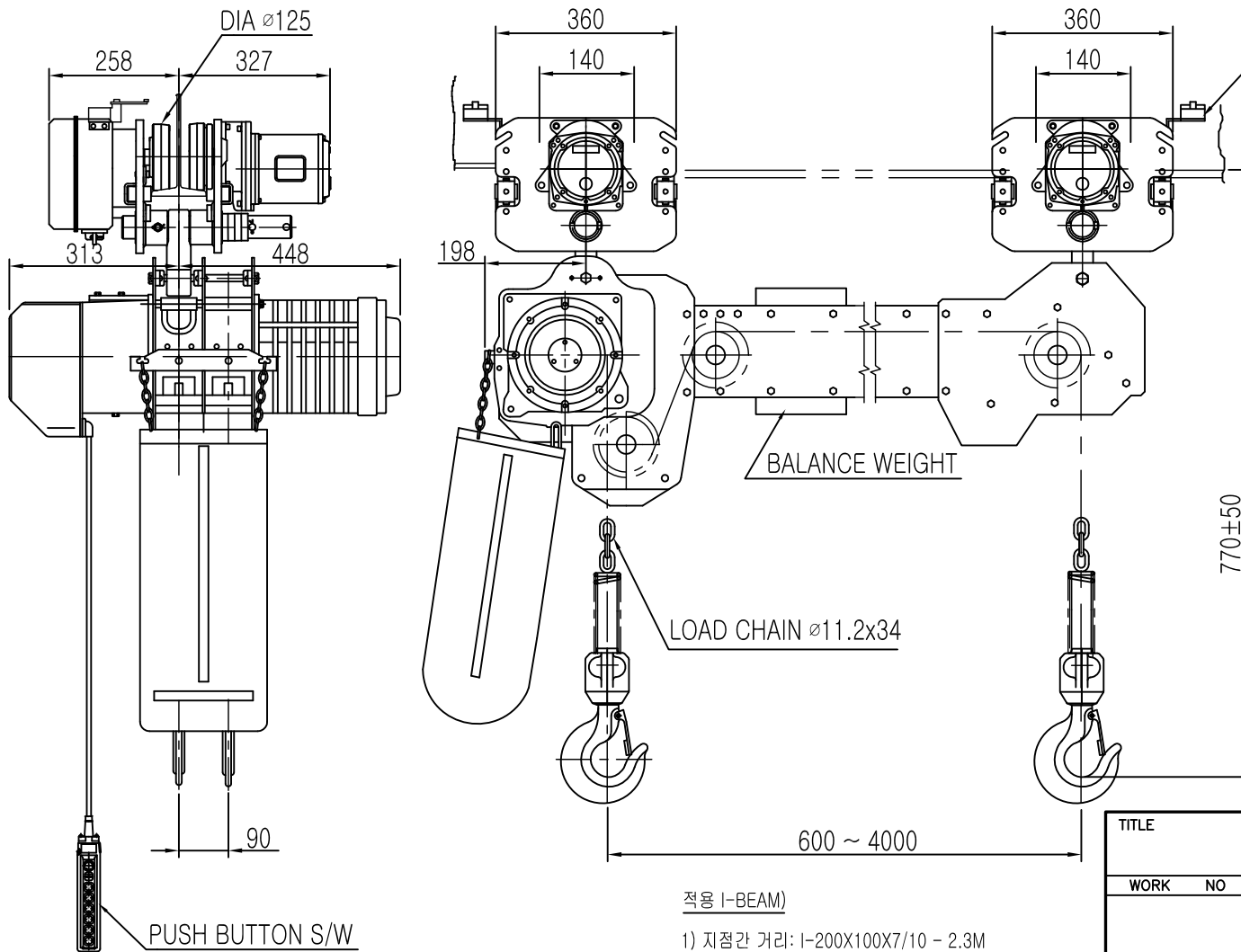

## SPECIFICATION

		LK-DHDAM-2.5S	
RATED LOAD	(TON)	2.5	
TESTING LOAD	(TON)	3.125	
LIFTING HEIGHT	(M)	50	
HOISTING	SPEED (M/MIN)	6.5	
	MOTOR (KW)	3.5kw x 4p	
TRAVERSING	SPEED (M/MIN)	20	14 20/7
	MOTOR (KW)	0.75kwx4p-2set	0.4kwx6p-2set 0.75/0.25kwx4/12p-2set
POWER SUPPLY		AC220.380.440.460.480Vx3 $\phi$ x 60 Hz	
OPERATING METHOD		P.B type ON . FL	
LOAD CHAIN		$\varnothing 11.2 \times 34$ (1FALL)	
WEIGHT	(KG)	655	
I-BEAM 적용폭		100 ~ 190MM	

### NOTE

- 1) 점검 설비를 갖출 것
- 2) 인허가 서류를 완성검사시 제출 할 것

적용 I-BEAM)

- 1) 지점간 거리 : I-200X100X7/10 - 2.3M
- 2) 지점간거리 : I-250X125X7.5/12.5-4.0M
- 3) 지점간거리 : I-300X150X10/18.5-6.0M
- 4) 지점간거리 : I-450X175X13/26-10M
- 5) 지점간거리 : I-600X190X13/25-14M

REV.NO	DATE	REVISION	DESCRIPTION	DRAWN	CHECKED	APPROVED

TITLE				PROJECTION	
ELECTRIC CHAIN HOIST					
WORK NO	WORK NAME			SCALE	Q' TY
	LK-DHDAM-2.5S			N S	1
DRAWN	CHECKED	REVIEWED	APPROVED	DRAWING NO	
김창기				CORD NO	
2010.08.01					

ON OMC

# L K HOIST

NO	DESCRIPTION	SIZE	MAT' L	Q' TY	WT (kg)	REMARKS

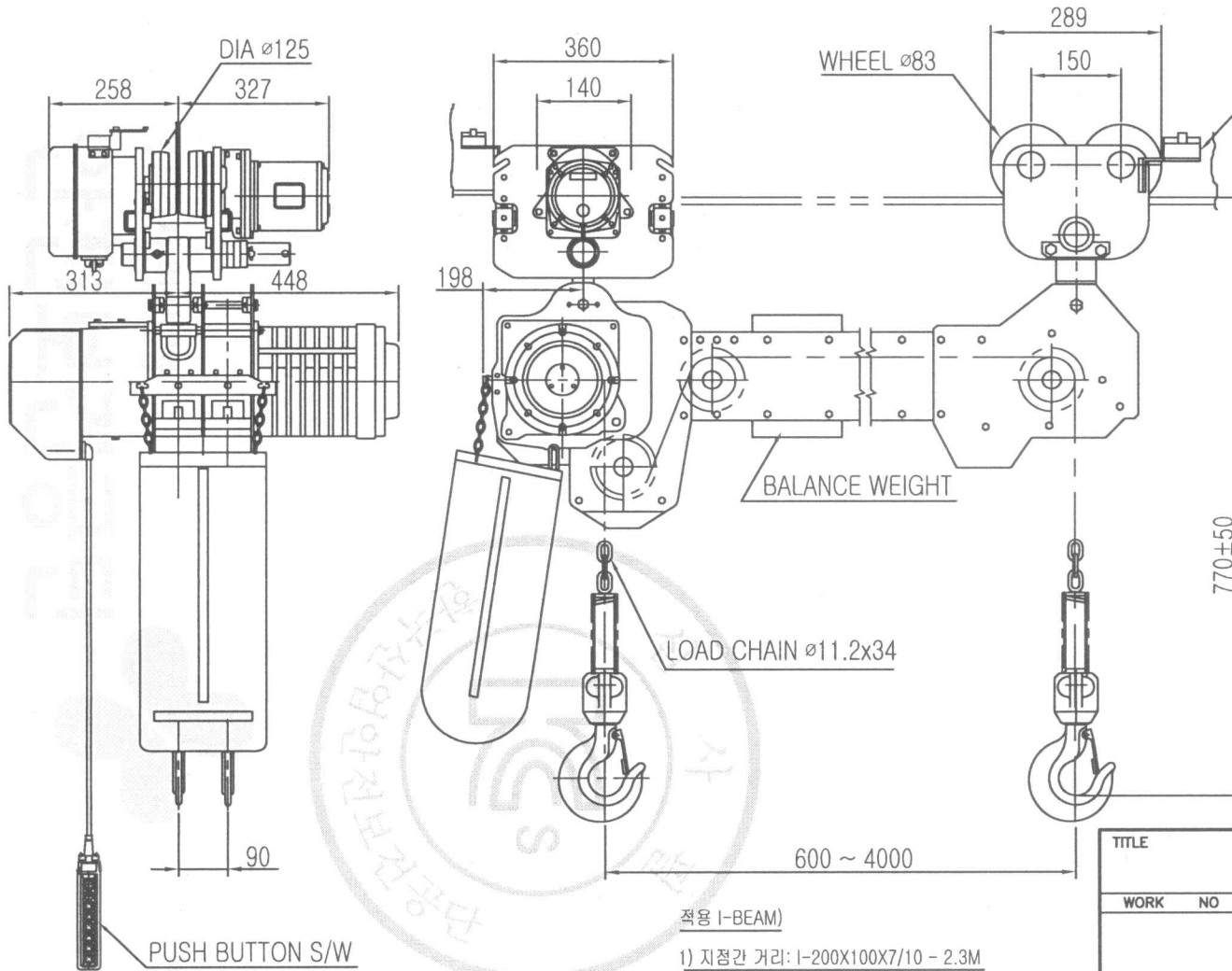

## SPECIFICATION

		LK-DHDAM-2.5S		
RATED LOAD	(TON)	2.5		
TESTING LOAD	(TON)	3.125		
LIFTING HEIGHT	(M)	50		
HOISTING	SPEED (M/MIN)	6.5		
	MOTOR (KW)	3.5kw x 4p		
TRAVERSING	SPEED (M/MIN)	20	14	20/7
	MOTOR (KW)	0.75kw x 4p	0.4kw x 6p	0.75/0.25kw x 4/12p
POWER SUPPLY		AC220.380.440.460.480Vx3ø x 60 Hz		
OPERATING METHOD		P.B type ON . FL		
LOAD CHAIN		ø11.2 X 34 (1FALL)		
WEIGHT	(KG)	655		
I-BEAM 적용폭		100 ~ 190MM		

NOTE)

- 1)점검 설비를 갖출 것
- 2)인허가 서류를 완성검사시 제출 할 것

적용 I-BEAM)

- 1) 지점간 거리 : I-200X100X7/10 - 2.3M
- 2) 지점간 거리 : I-250X125X7.5/12.5-4.0M
- 3) 지점간 거리 : I-300X150X10/18.5-6.0M
- 4) 지점간 거리 : I-450X175X13/26-10M
- 5) 지점간 거리 : I-600X190X13/25-14M

REV.NO	DATE	REVISION	DESCRIPTION	DRAWN	CHECKED	APPROVED

TITLE					PROJECTION	
ELECTRIC CHAIN HOIST						
WORK NO	WORK NAME				SCALE	Q' TY
	LK-DHDAM-2.5S				N S	1
DRAWN	CHECKED	REVIEWED	APPROVED	DRAWING NO		
김 창 기						
2010.08.01				CORD NO		
<b>L K HOIST CO., LTD.</b>						

물범목제 및 배포금지

# L K HOIST

ON 5MG

NO	DESCRIPTION	SIZE	MAT'L	Q'TY	WT (kg)	REMARKS

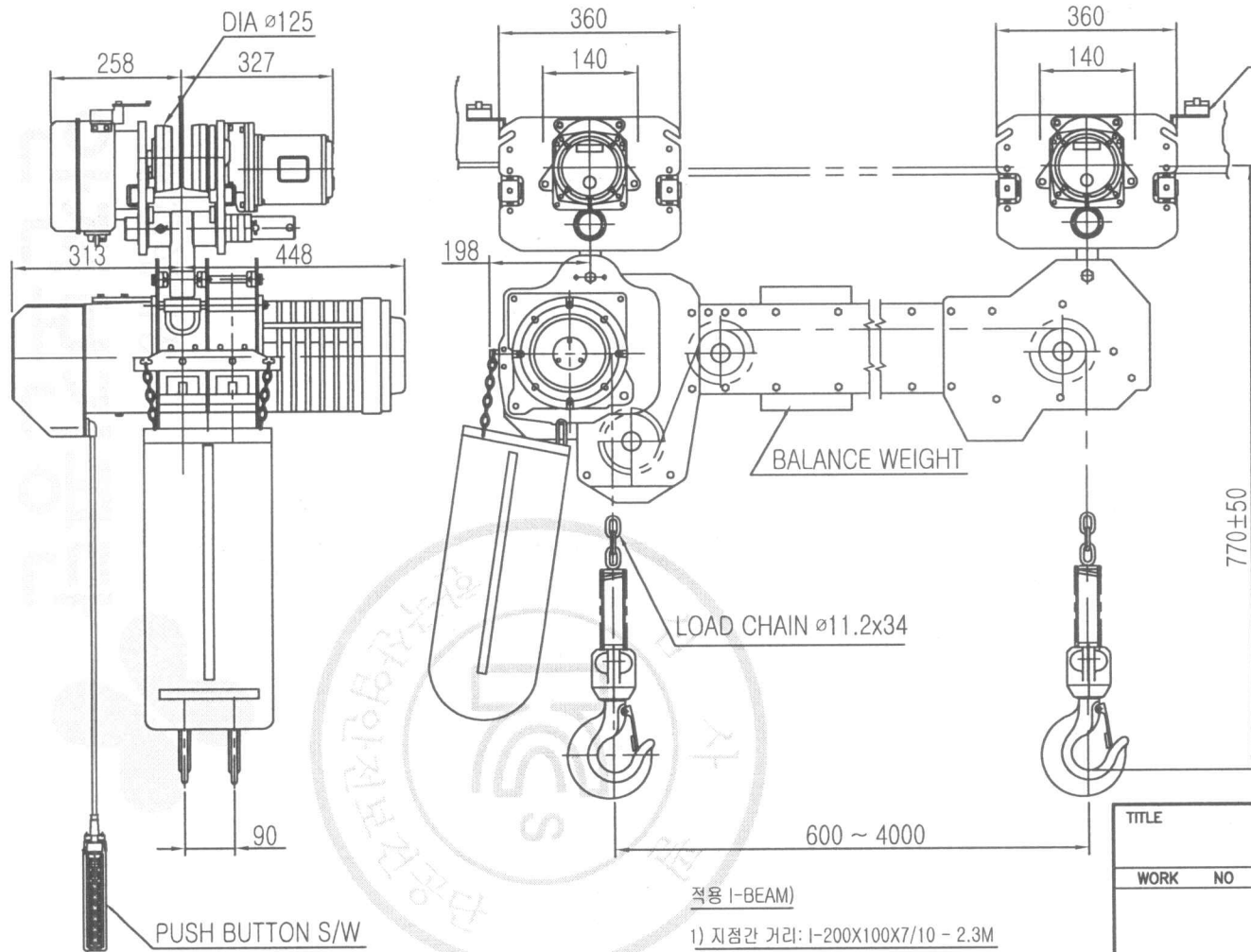

## SPECIFICATION

		LK-DHDAM-2.5S		
RATED LOAD	(TON)	2.5		
TESTING LOAD	(TON)	3.125		
LIFTING HEIGHT	(M)	50		
HOISTING	SPEED (M/MIN)	6.5		
	MOTOR (KW)	3.5kw x 4p		
TRAVERSING	SPEED (M/MIN)	20	14	20/7
	MOTOR (KW)	0.75kwx4p-2set	0.4kwx6p-2set	0.75/0.25kwx4/12p-2set
POWER SUPPLY		AC220,380,440,460,480Vx3ø x 60 Hz		
OPERATING METHOD		P.B type ON . FL		
LOAD CHAIN		ø11.2 X 34 (1FALL)		
WEIGHT	(KG)	655		
I-BEAM 적용폭		100 ~ 190MM		

NOTE)

- 1)정검 설비를 갖출 것
- 2)인허가 서류를 완성검사시 제출 할 것

적용 I-BEAM)

- 1) 지점간 거리: I-200X100X7/10 - 2.3M
- 2) 지점간거리 : I-250X125X7.5/12.5-4.0M
- 3) 지점간거리 : I-300X150X10/18.5-6.0M
- 4) 지점간거리 : I-450X175X13/26-10M
- 5) 지점간거리 : I-600X190X13/25-14M

TITLE					PROJECTION	
ELECTRIC CHAIN HOIST						
WORK NO	WORK NAME				SCALE	Q'TY
	LK-DHDAM-2.5S				N S	1
DRAWN	CHECKED	REVIEWED	APPROVED	DRAWING NO		
김 창 기				CORD NO		
2010.08.01						

REV.NO	DATE	REVISION	DESCRIPTION	DRAWN	CHECKED	APPROVED

물범북제 및 배포금지