

POWER CIRCUIT
TRAVELLING POWER SUPPLY SYSTEM

ADDRESS NO.
A1

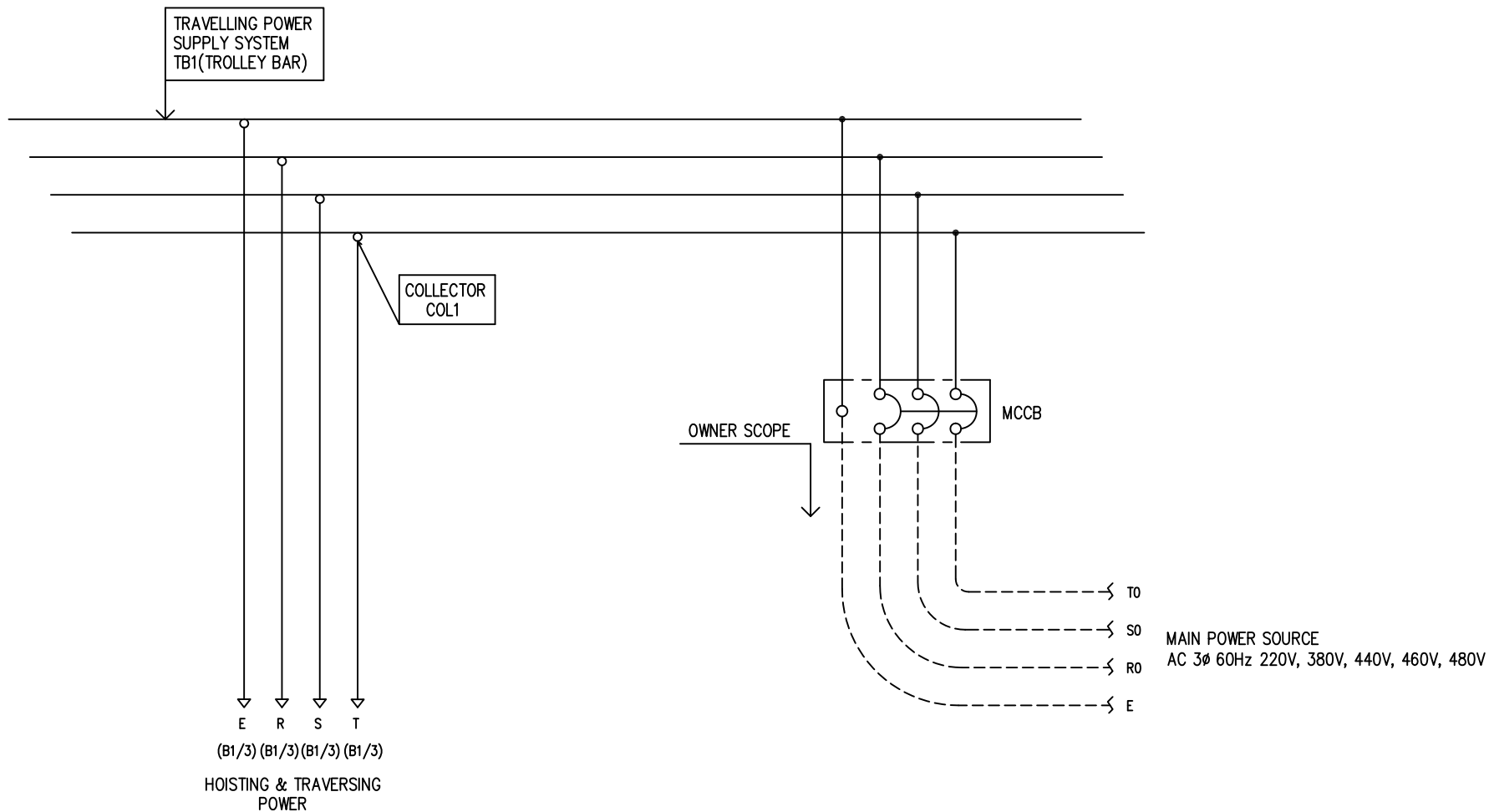

-NOTE-

- 1. - - - - MARKED OWNER SCOPE
- 2. ——— MARKED CRAIN MAKER SCOPE

TITLE MAIN POWER CIRCUIT DIAGRAM1				PROJECTION 	
WORK NO 601	WORK NAME LTM			SCALE 1/1	Q' TY 1
220V, 380V, 440V, 460V, 480V					
DRAWN LEE G.H. 2010.07.20	CHECKED	REVIEWED	APPROVED	DRAWING NO	
				CODE NO	
L K HOIST CO., LTD.					

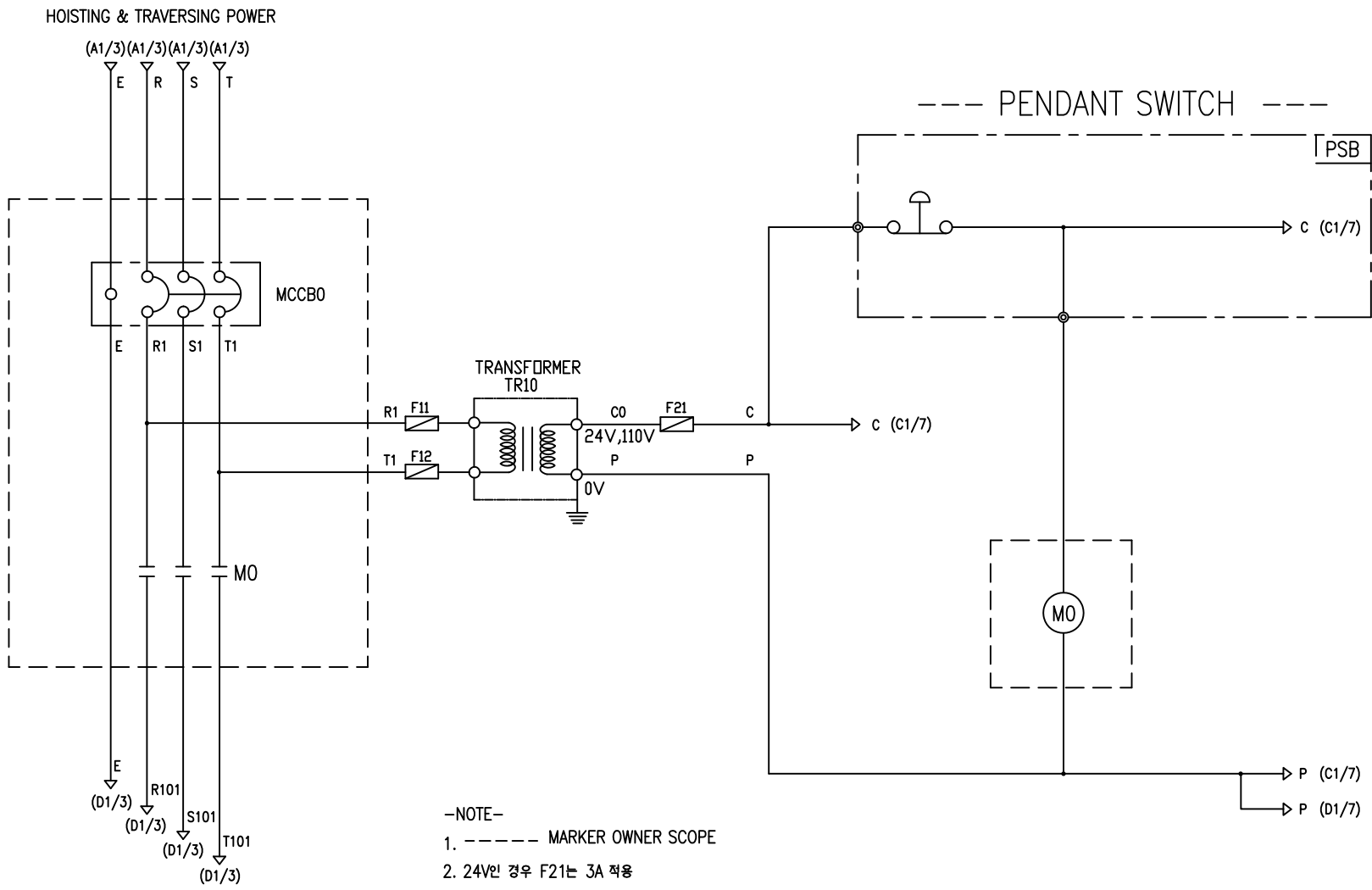

-NOTE-

1. ----- MARKER OWNER SCOPE
2. 24V인 경우 F21는 3A 적용

SPECIFICATION	NO FUSE BREAKER	MAGNET CONTACT	TRANSFORMER	FUZE	
SYMBOLS	MCCB0	MO	TR10	F11, F12, F21	
DESCRIPTION	220V	20A	30VA	1A	
	380V	15A			
	440V	10A			
	460V	10A			
	470V	10A			
MAKER	LS	LS	DONGA	LK	-

TITLE MAIN POWER & CONTROL CIRCUIT DIAGRAM						PROJECTION 	
WORK NO 602		WORK NAME LTM				SCALE 1/1	
220V, 380V, 440V, 460V, 480V		DRAWN LEE.G.H		CHECKED		REVIEWED	
2010.07.20		APPROVED		DRAWING NO LTM		CODE NO	
L K HOIST CO., LTD.							

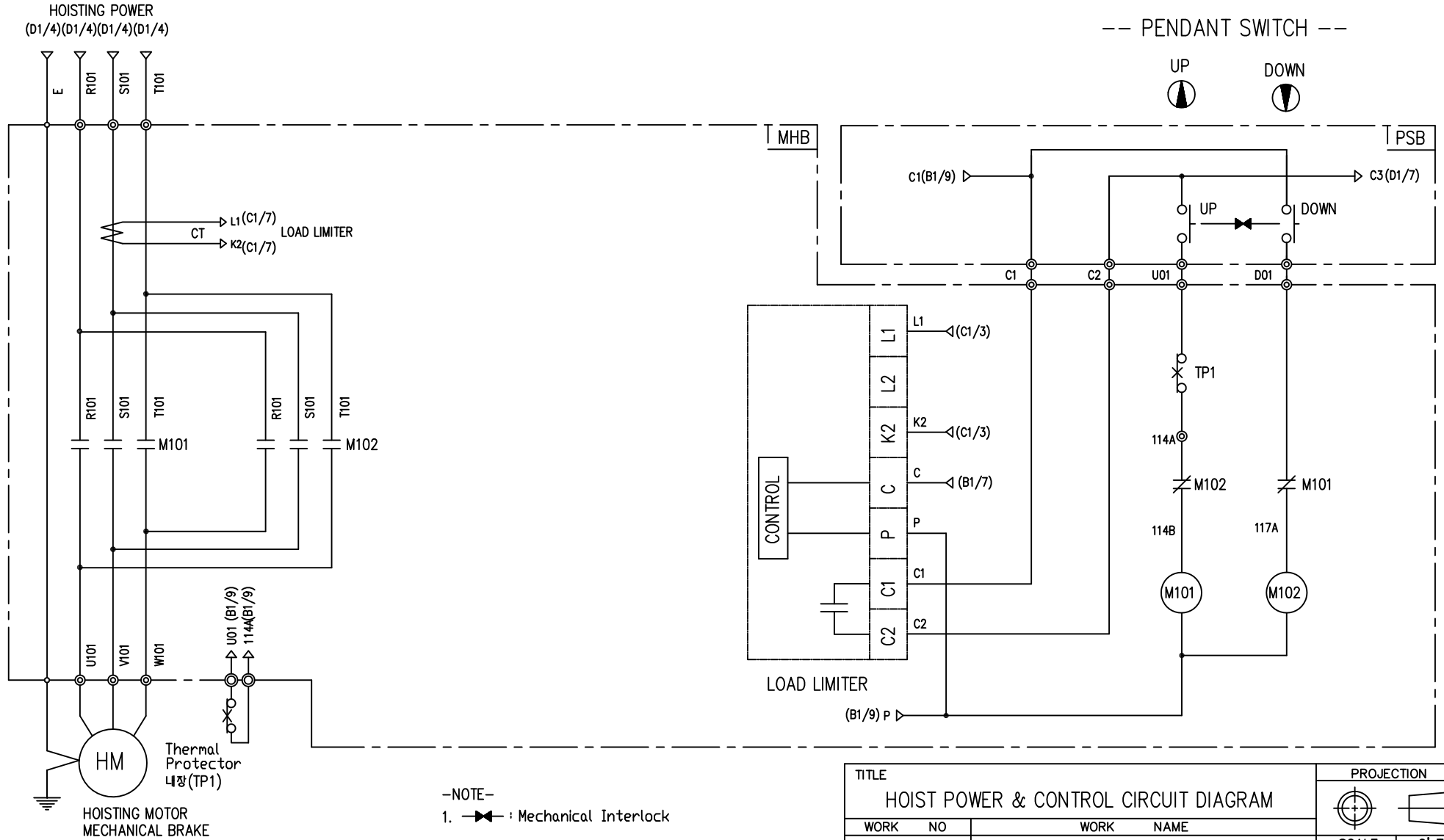

-NOTE-
 1. : Mechanical Interlock

SPECIFICATION	MAGNET CONTACT	LOAD LIMITER	Thermal Protector	HOIST MOTOR	
SYMBOLS	M101, M102	-	TP1	HM	
DESCRIPTION	GMC12 DMC12	LKDL-50A	17AM032	1.8Kw * 4P	1.2Kw * 6P
MAKER	LS DONGA	LK	Texas Instruments	LK	

TITLE HOIST POWER & CONTROL CIRCUIT DIAGRAM						PROJECTION 	
WORK NO. 603		WORK NAME LTM 220V, 380V, 440V, 460V, 480V				SCALE 1/1	Q' TY 1
DRAWN LEE.G.H 2010.07.20	CHECKED	REVIEWED	APPROVED	MODEL LTM	CODE NO		
L K HOIST CO., LTD.							

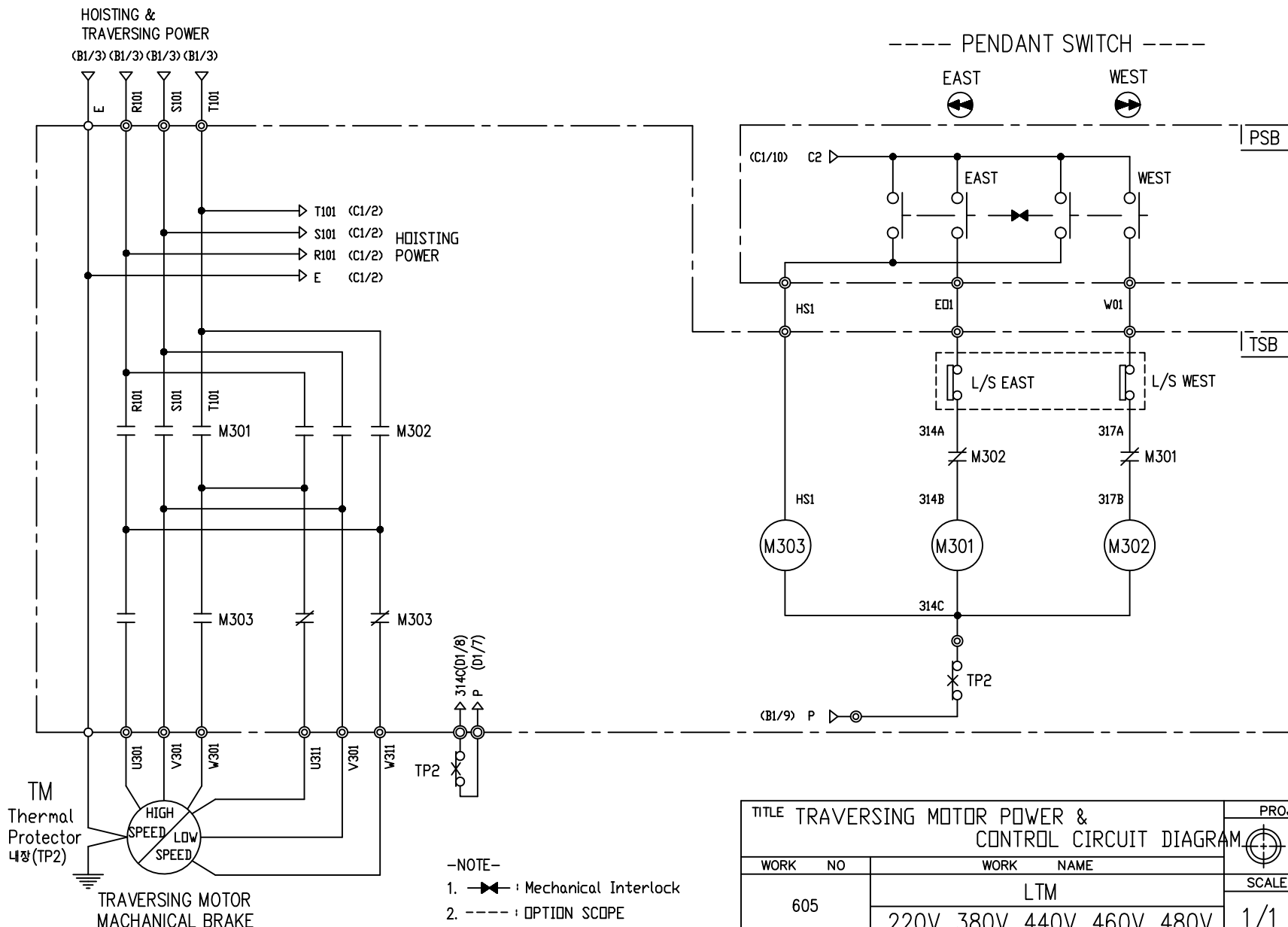

TITLE TRAVERSING MOTOR POWER & CONTROL CIRCUIT DIAGRAM						PROJECTION	
WORK NO. 605						WORK NAME LTM	
220V, 380V, 440V, 460V, 480V						SCALE 1/1	Q' TY 1
DRAWN	CHECKED	REVIEWED	APPROVED	MODEL	LTM		
LEE.G.H				CODE NO			
2010.07.20							
LK L K HOIST CO., LTD.							

SPECIFICATION	MAGNET CONTACT	Thermal Protector	TRAVERSING MOTOR
SYMBOLS	M301, M302, M303	TP2	TM
DESCRIPTION	GMC12 DMC12	17AM032	0.3/0.15KW *2/8P
MAKER	LS DONGA	Texas Instruments	LK

SCHEDULE OF TECHNICAL DATA

1. SERVICE	HOISTING
2. MANUFACTURE	LK HOIST CO. LTD
3. MOTOR MODEL NO	1.8 - 4 - 22
4. RATED POWER	1.8 KW × 4 P
5. RATED VOLTAGE AND FREQUENCY	220 V 60HZ
6. MOTOR TYPE	SQUIRREL CAGE ROTOR TYPE
7. RATING	30 MIN
8. LOCATION	IN-DOOR , OUTDOOR
9. INSULATION CLASS	B
10. DESIGN TEMPERATURE RISE (BY RESISTANCE)	80℃
11. FULL LOAD SPEED	1720 RPM
12. FULL LOAD CURRENT	8.5 A
13. STARTING CURRENT AT RATED VOLTAGE	42.8 A
14. MINIMUM STARTING VOLTAGE	198 V
15. EFFICIENCY AT 100% RATED LOAD	69.5 %
16. POWER FACTOR AT 100% RATED LOAD	66.7 %
17. STARTING TORQUE	242 %
18. TYPE OF ENCLOSURE	전폐형
19. TYPE OF BEARING	PL : 6008DD OPL : 6207ZZ
20. MOUNTING	VERTICAL
21. MAXIMUM AMBIENT TEMPURE	40℃
22. BEARING LUBRICATION	GREASE
23. STARTING METHOD	FULL VOLTAGE

SCHEDULE OF TECHNICAL DATA

1. SERVICE	HOISTING
2. MANUFACTURE	LK HOIST CO. LTD
3. MOTOR MODEL NO	1.2 - 6 - 22
4. RATED POWER	1.2 KW × 6 P
5. RATED VOLTAGE AND FREQUENCY	220 V 60HZ
6. MOTOR TYPE	SQUIRREL CAGE ROTOR TYPE
7. RATING	30 MIN
8. LOCATION	IN-DOOR , OUTDOOR
9. INSULATION CLASS	B
10. DESIGN TEMPERATURE RISE (BY RESISTANCE)	80℃
11. FULL LOAD SPEED	1150 RPM
12. FULL LOAD CURRENT	8.9 A
13. STARTING CURRENT AT RATED VOLTAGE	44.5 A
14. MINIMUM STARTING VOLTAGE	198 V
15. EFFICIENCY AT 100% RATED LOAD	67.9 %
16. POWER FACTOR AT 100% RATED LOAD	65 %
17. STARTING TORQUE	242 %
18. TYPE OF ENCLOSURE	전폐형
19. TYPE OF BEARING	PL : 6008DD OPL : 6207ZZ
20. MOUNTING	VERTICAL
21. MAXIMUM AMBIENT TEMPURE	40℃
22. BEARING LUBRICATION	GREASE
23. STARTING METHOD	FULL VOLTAGE

SCHEDULE OF TECHNICAL DATA

1. SERVICE	TRAVERSING
2. MANUFACTURE	LK HOIST CO. LTD
3. MOTOR MODEL NO	0.3 - 2 - 22
4. RATED POWER	0.3 KW × 2 P
5. RATED VOLTAGE AND FREQUENCY	220 V 60HZ
6. MOTOR TYPE	SQUIRREL CAGE ROTOR TYPE
7. RATING	15 MIN
8. LOCATION	IN-DOOR , OUTDOOR
9. INSULATION CLASS	B
10. DESIGN TEMPERATURE RISE (BY RESISTANCE)	100℃
11. FULL LOAD SPEED	3440 RPM
12. FULL LOAD CURRENT	2.5 A
13. STARTING CURRENT AT RATED VOLTAGE	12.5 A
14. MINIMUM STARTING VOLTAGE	198 V
15. EFFICIENCY AT 100% RATED LOAD	57 %
16. POWER FACTOR AT 100% RATED LOAD	56.3 %
17. STARTING TORQUE	237 %
18. TYPE OF ENCLOSURE	전폐형
19. TYPE OF BEARING	PL : 6008DD OPL : 6207ZZ
20. MOUNTING	VERTICAL
21. MAXIMUM AMBIENT TEMPURE	40℃
22. BEARING LUBRICATION	GREASE
23. STARTING METHOD	FULL VOLTAGE

SCHEDULE OF TECHNICAL DATA

1. SERVICE	TRAVERSING
2. MANUFACTURE	LK HOIST CO. LTD
3. MOTOR MODEL NO	0.2 - 4 - 22
4. RATED POWER	0.2 KW × 4 P
5. RATED VOLTAGE AND FREQUENCY	220 V 60HZ
6. MOTOR TYPE	SQUIRREL CAGE ROTOR TYPE
7. RATING	15 MIN
8. LOCATION	IN-DOOR , OUTDOOR
9. INSULATION CLASS	B
10. DESIGN TEMPERATURE RISE (BY RESISTANCE)	100℃
11. FULL LOAD SPEED	1690 RPM
12. FULL LOAD CURRENT	2.0 A
13. STARTING CURRENT AT RATED VOLTAGE	10.2 A
14. MINIMUM STARTING VOLTAGE	198 V
15. EFFICIENCY AT 100% RATED LOAD	52.1 %
16. POWER FACTOR AT 100% RATED LOAD	50.4 %
17. STARTING TORQUE	237 %
18. TYPE OF ENCLOSURE	전폐형
19. TYPE OF BEARING	PL : 6008DD OPL : 6207ZZ
20. MOUNTING	VERTICAL
21. MAXIMUM AMBIENT TEMPURE	40℃
22. BEARING LUBRICATION	GREASE
23. STARTING METHOD	FULL VOLTAGE

SCHEDULE OF TECHNICAL DATA

1. SERVICE	TRAVERSING
2. MANUFACTURE	LK HOIST CO. LTD
3. MOTOR MODEL NO	0.3/0.15 - 2/8 - 22
4. RATED POWER	0.3/0.15 KW × 2/8 P
5. RATED VOLTAGE AND FREQUENCY	220 V 60HZ
6. MOTOR TYPE	SQUIRREL CAGE ROTOR TYPE
7. RATING	15 MIN
8. LOCATION	IN-DOOR , OUTDOOR
9. INSULATION CLASS	B
10. DESIGN TEMPERATURE RISE (BY RESISTANCE)	100℃
11. FULL LOAD SPEED	3440 / 840 RPM
12. FULL LOAD CURRENT	2.5 / 2.3 A
13. STARTING CURRENT AT RATED VOLTAGE	12.6/ 11.5 A
14. MINIMUM STARTING VOLTAGE	198 V
15. EFFICIENCY AT 100% RATED LOAD	57 / 42.2 %
16. POWER FACTOR AT 100% RATED LOAD	55.3 / 40.6 %
17. STARTING TORQUE	237 / 237 %
18. TYPE OF ENCLOSURE	전폐형
19. TYPE OF BEARING	PL : 6008DD OPL : 6207ZZ
20. MOUNTING	VERTICAL
21. MAXIMUM AMBIENT TEMPURE	40℃
22. BEARING LUBRICATION	GREASE
23. STARTING METHOD	FULL VOLTAGE