

ON 9MG

# L K HOIST

NO	DESCRIPTION	SIZE	MAT' L	Q' TY	WT (kg)	REMARKS

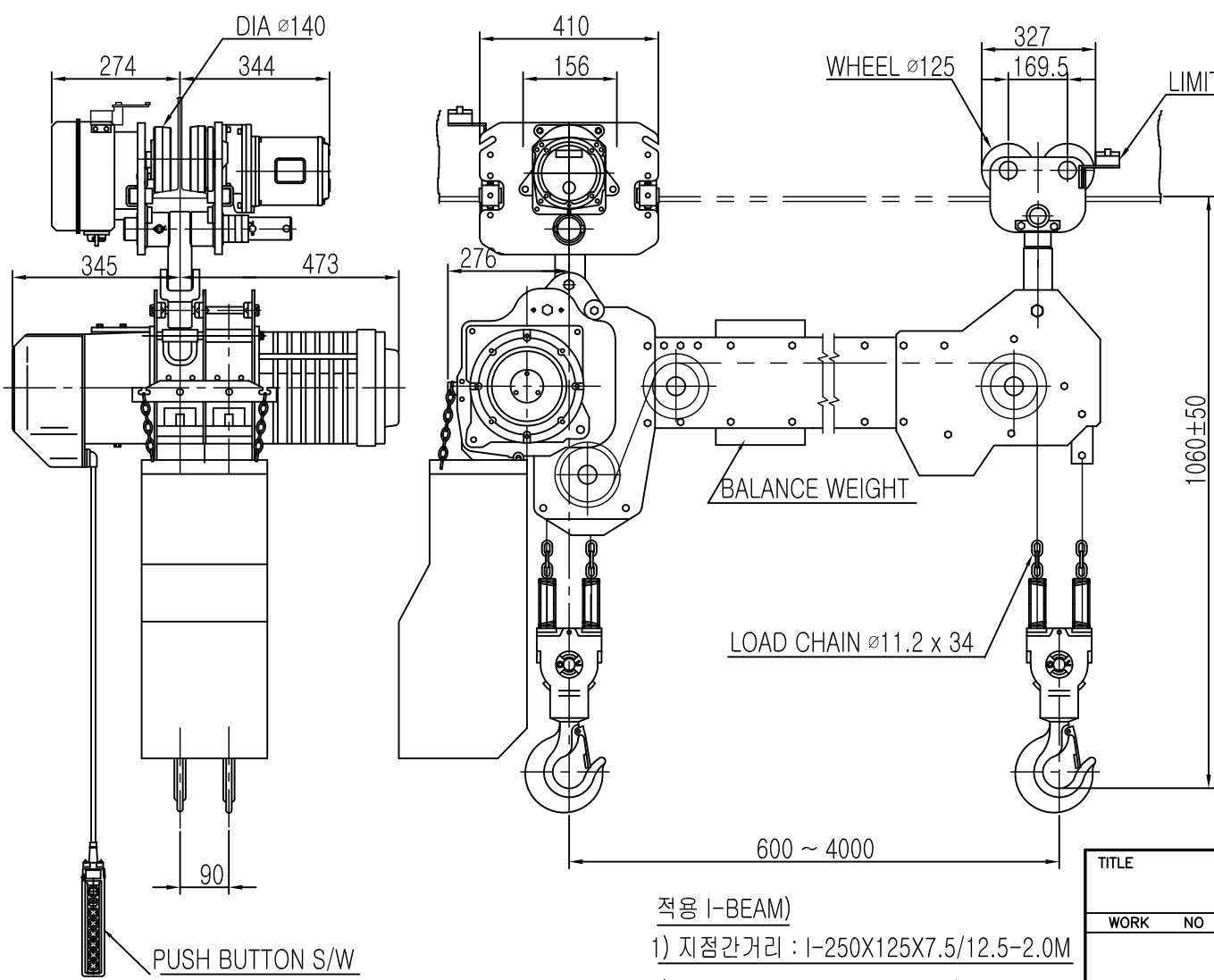

## SPECIFICATION

		LK-DHDBM-5W		
RATED LOAD	(TON)	5.0		
TESTING LOAD	(TON)	6.25		
LIFTING HEIGHT	(M)	50		
HOISTING	SPEED (M/MIN)	3.25/1.0		
	MOTOR (KW)	4.4/2.2kw x 2/6p		
TRAVERSING	SPEED (M/MIN)	20	14	20/7
	MOTOR (KW)	0.75kw x 4p	0.4kw x 6p	0.75/0.25kw x 4/12p
POWER SUPPLY	AC220.380.440.460.480Vx3ø x 60 Hz			
OPERATING METHOD	P.B type ON . FL			
LOAD CHAIN	ø11.2 X 34 (2FALL)			
WEIGHT	(KG)	1087		
I-BEAM 적용폭	125 ~ 190MM			

NOTE)

- 1) 점검 설비를 갖출 것
- 2) 인허가 서류를 완성검사시 제출 할 것

적용 I-BEAM)

- 1) 지점간거리 : I-250X125X7.5/12.5-2.0M
- 2) 지점간거리 : I-300X150X10/18.5-4.5M
- 3) 지점간거리 : I-450X175X13/26-8.5M
- 4) 지점간거리 : I-600X190X13/25-10M

REV.NO	DATE	REVISION	DESCRIPTION	DRAWN	CHECKED	APPROVED

TITLE				PROJECTION	
ELECTRIC CHAIN HOIST					
WORK NO	WORK NAME			SCALE	Q' TY
	LK-DHDBM-5W			N/S	1
DRAWN	CHECKED	REVIEWED	APPROVED	DRAWING NO	CORD NO
김창기					
2010.08.01					

**LK** L K HOIST CO., LTD.

ON 9MG

# L K HOIST

NO	DESCRIPTION	SIZE	MAT' L	Q' TY	WT (kg)	REMARKS
----	-------------	------	--------	-------	---------	---------

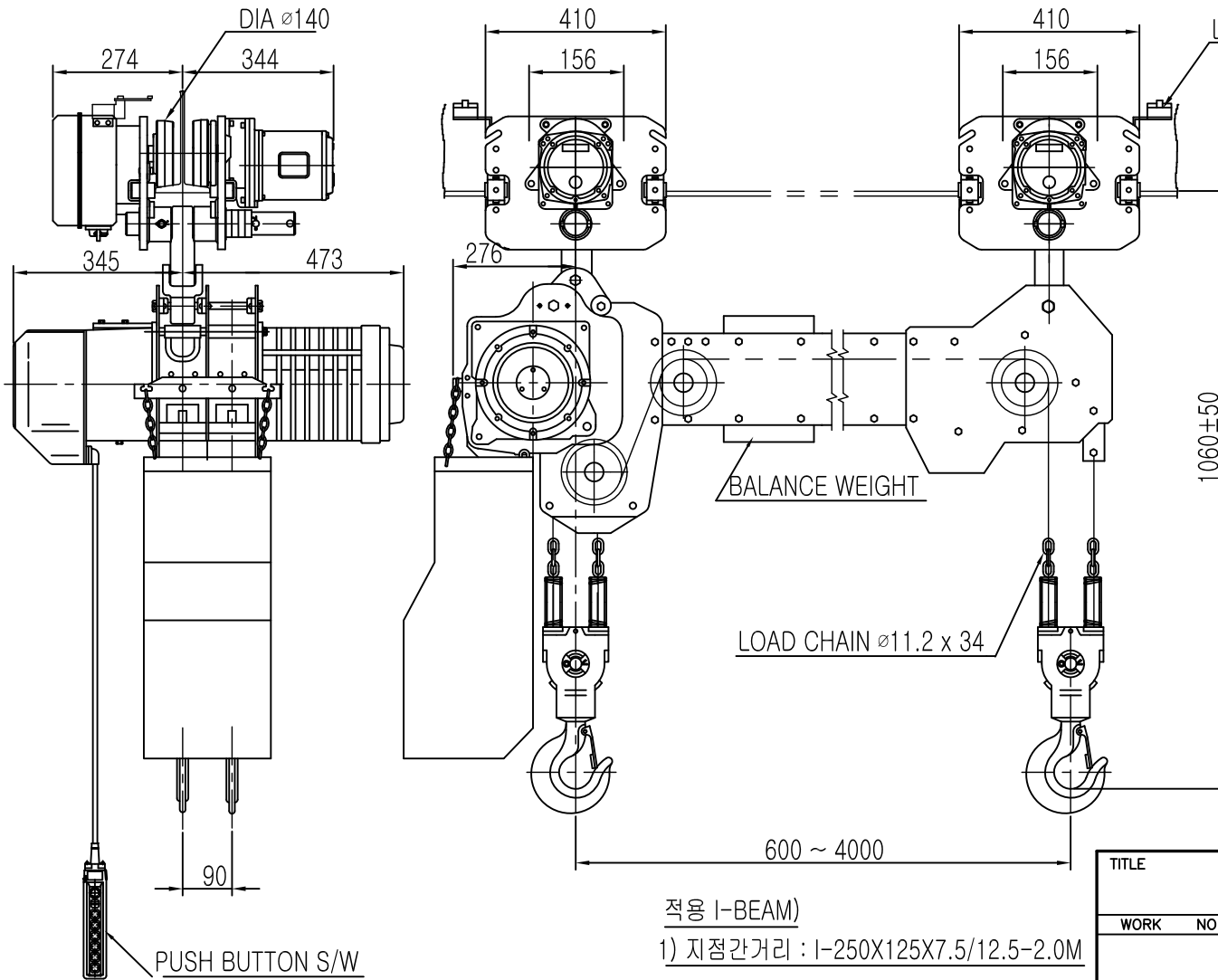

## SPECIFICATION

		LK-DHDBM-5W		
RATED LOAD	(TON)	5.0		
TESTING LOAD	(TON)	6.25		
LIFTING HEIGHT	(M)	50		
HOISTING	SPEED (M/MIN)	3.25/1.0		
	MOTOR (KW)	4.4/2.2kw x 2/6p		
TRAVERSING	SPEED (M/MIN)	20	14	20/7
	MOTOR (KW)	0.75kwx4p-2set	0.4kwx6p-2set	0.75/0.25kwx4/12p-2set
POWER SUPPLY		AC220.380.440.460.480Vx3 $\phi$ x 60 Hz		
OPERATING METHOD		P.B type ON . FL		
LOAD CHAIN		$\varnothing 11.2 \times 34$ (2FALL)		
WEIGHT	(KG)	1087		
I-BEAM 적용폭		125 ~ 190MM		

NOTE)

- 1)점검 설비를 갖출 것
- 2)인허가 서류를 완성검사시 제출 할 것

적용 I-BEAM)

- 1) 지점간거리 : I-250X125X7.5/12.5-2.0M
- 2) 지점간거리 : I-300X150X10/18.5-4.5M
- 3) 지점간거리 : I-450X175X13/26-8.5M
- 4) 지점간거리 : I-600X190X13/25-10M

REV.NO	DATE	REVISION	DESCRIPTION	DRAWN	CHECKED	APPROVED
--------	------	----------	-------------	-------	---------	----------

TITLE					PROJECTION	
ELECTRIC CHAIN HOIST						
WORK NO	WORK NAME				SCALE	Q' TY
	LK-DHDBM-5W				N/S	1
DRAWN	CHECKED	REVIEWED	APPROVED	DRAWING NO		
김 창 기				CORD NO		
2010.08.01						
L K HOIST CO., LTD.						

ON GMD

# L K HOIST

NO	DESCRIPTION	SIZE	MAT'L	Q'TY	WT (kg)	REMARKS

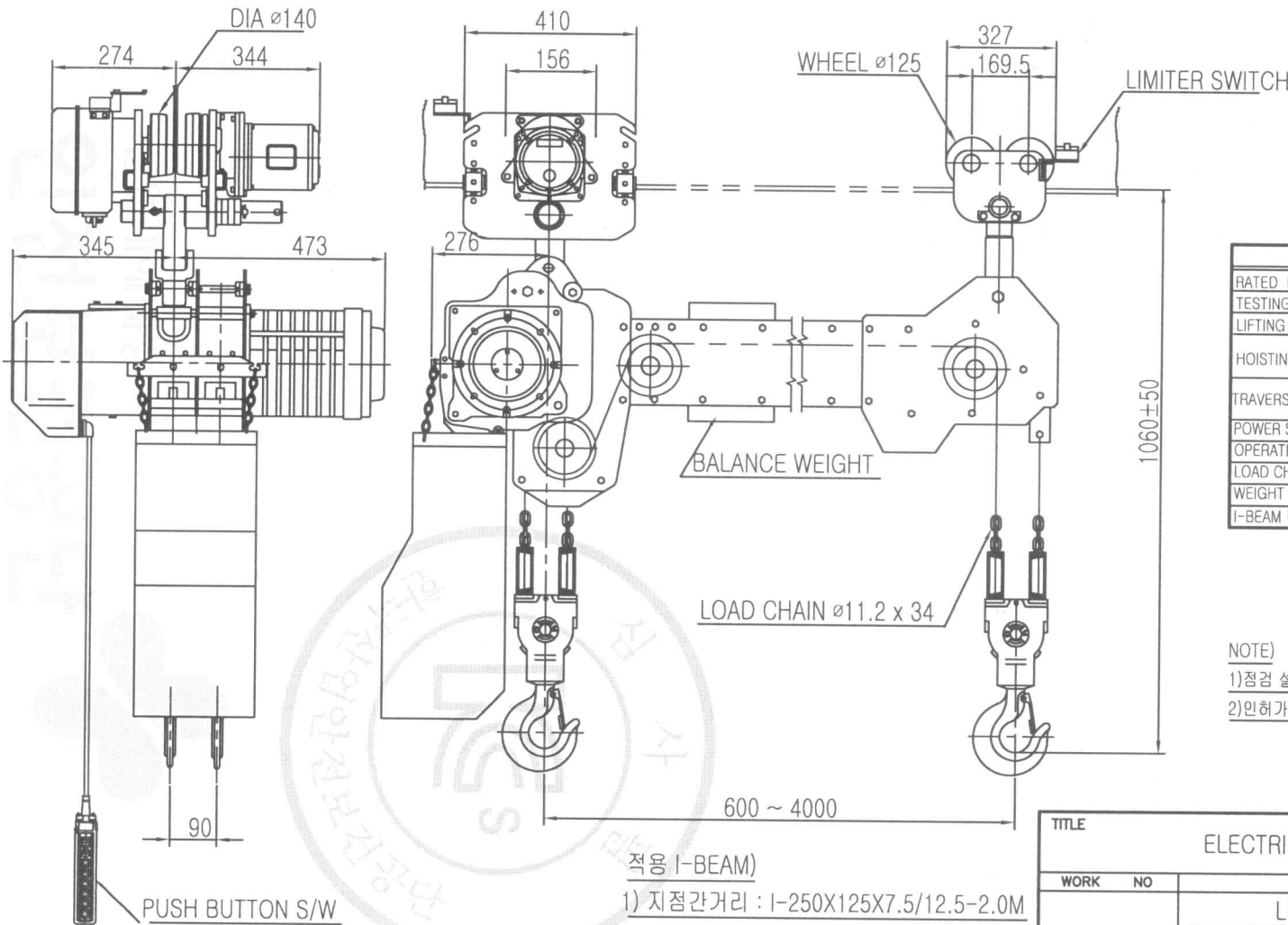

## SPECIFICATION

		LK-DHDBM-5W	
RATED LOAD (TON)		5.0	
TESTING LOAD (TON)		6.25	
LIFTING HEIGHT (M)		50	
HOISTING	SPEED (M/MIN)	3.25/1.0	
	MOTOR (KW)	4.4/2.2kw x 2/6p	
TRAVERSING	SPEED (M/MIN)	20	14 20/7
	MOTOR (KW)	0.75kw x 4p	0.4kw x 6p 0.75/0.25kw x 4/12p
POWER SUPPLY		AC220.380.440.460.480V x 3ø x 60 Hz	
OPERATING METHOD		P.B type ON . FL	
LOAD CHAIN		ø11.2 X 34 (2FALL)	
WEIGHT (KG)		1087	
I-BEAM 적용폭		125 ~ 190MM	

NOTE)

- 1) 점검 설비를 갖추어 것
- 2) 인허가 서류를 완성검사서 제출 할 것

적용 I-BEAM)

- 1) 지점간거리 : I-250X125X7.5/12.5-2.0M
- 2) 지점간거리 : I-300X150X10/18.5-4.5M
- 3) 지점간거리 : I-450X175X13/26-8.5M
- 4) 지점간거리 : I-600X190X13/25-10M

TITLE				PROJECTION	
ELECTRIC CHAIN HOIST					
WORK NO	WORK NAME			SCALE	Q' TY
	LK-DHDBM-5W			N/S	1
DRAWN	CHECKED	REVIEWED	APPROVED	DRAWING NO	
김 창 기				CORD NO	
2010.08.01					

REV.NO	DATE	REVISION DESCRIPTION	DRAWN	CHECKED	APPROVED

**LK** L K HOIST CO., LTD.

물범복제 및 배포금지

# L K HOIST

ON DWG

NO	DESCRIPTION	SIZE	MAT' L	Q' TY	WT (kg)	REMARKS

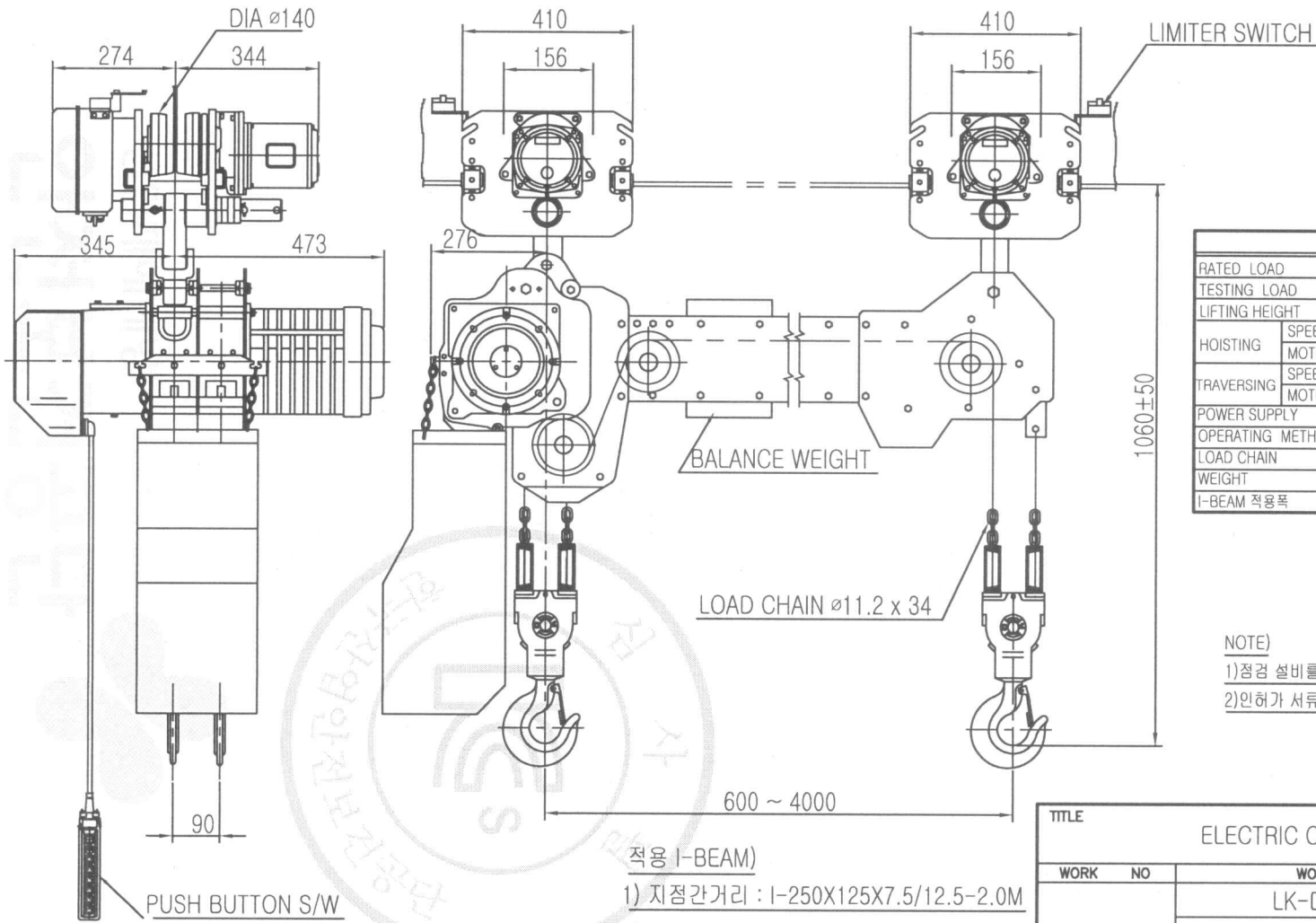

## SPECIFICATION

		LK-DHDBM-5W	
RATED LOAD (TON)	5.0		
TESTING LOAD (TON)	6.25		
LIFTING HEIGHT (M)	50		
HOISTING	SPEED (M/MIN)	3.25/1.0	
	MOTOR (KW)	4.4/2.2kw x 2/6p	
TRAVERSING	SPEED (M/MIN)	14	20/7
	MOTOR (KW)	0.75kwx4p-2set	0.4kwx6p-2set   0.75/0.25kwx4/12p-2set
POWER SUPPLY	AC220,380,440,460,480Vx3ø x 60 Hz		
OPERATING METHOD	P.B type ON . FL		
LOAD CHAIN	ø11.2 X 34 (2FALL)		
WEIGHT (KG)	1087		
I-BEAM 적용폭	125 ~ 190MM		

NOTE)

- 1)점검 설비를 갖출 것
- 2)인허가 서류를 완성검사시 제출 할 것

적용 I-BEAM)

- 1) 지점간거리 : I-250X125X7.5/12.5-2.0M
- 2) 지점간거리 : I-300X150X10/18.5-4.5M
- 3) 지점간거리 : I-450X175X13/26-8.5M
- 4) 지점간거리 : I-600X190X13/25-10M

REV.NO	DATE	REVISION	DESCRIPTION	DRAWN	CHECKED	APPROVED

TITLE					PROJECTION	
ELECTRIC CHAIN HOIST						
WORK NO	WORK NAME				SCALE	Q' TY
	LK-DHDBM-5W				N/S	1
DRAWN	CHECKED	REVIEWED	APPROVED	DRAWING NO		
김 창 기						
2010.08.01				CORD NO		
L K HOIST CO., LTD.						

물범복제 및 배포금지