

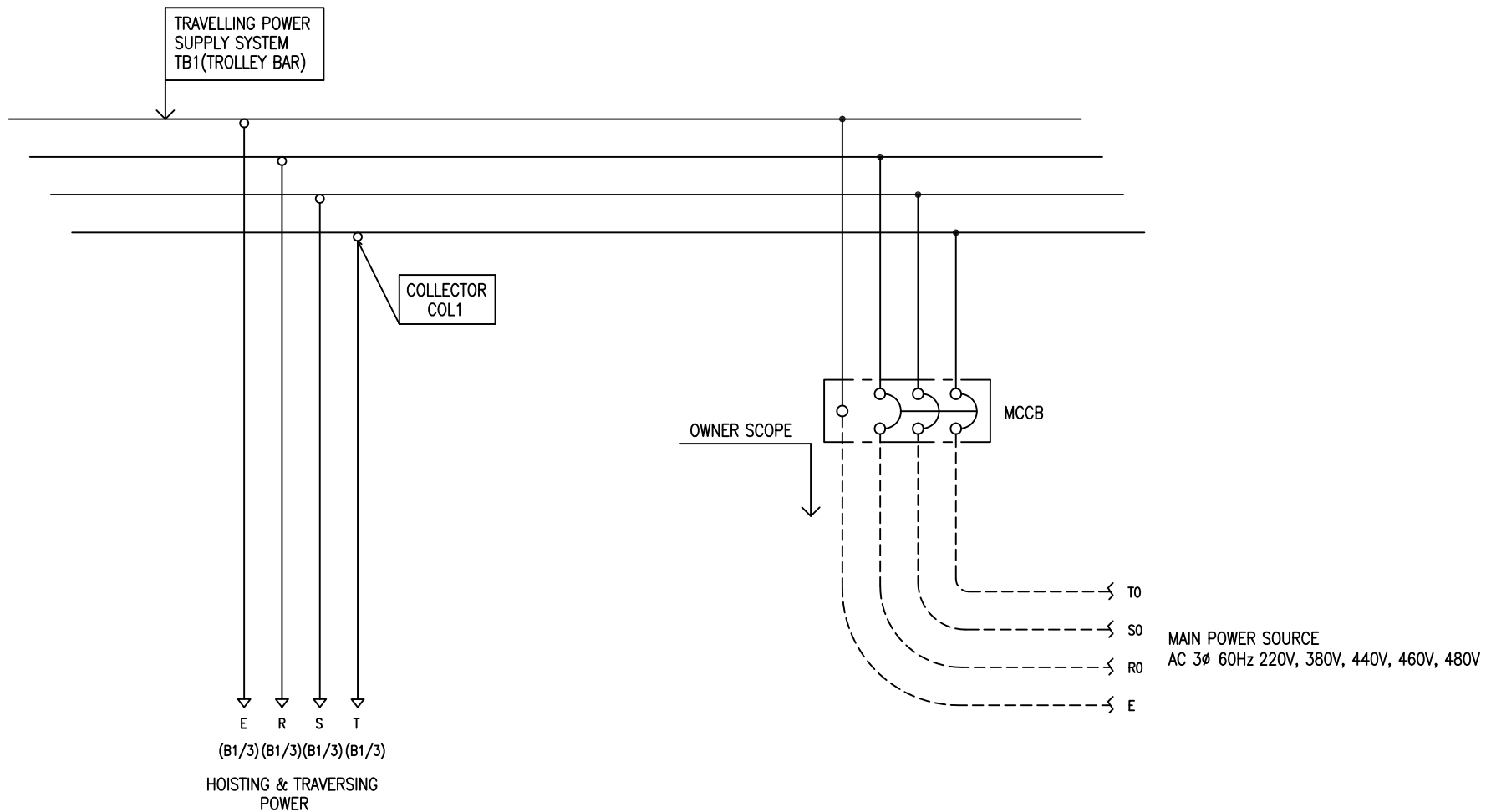

POWER CIRCUIT
TRAVELLING POWER SUPPLY SYSTEM

ADDRESS NO.
A1

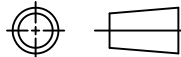

-NOTE-

- 1. - - - - MARKED OWNER SCOPE
- 2. ——— MARKED CRAIN MAKER SCOPE

TITLE MAIN POWER CIRCUIT DIAGRAM1				PROJECTION 	
WORK NO	WORK NAME			SCALE	Q' TY
601	EDAM			N/S	1
220V, 380V, 440V, 460V, 480V					
DRAWN	CHECKED	REVIEWED	APPROVED	DRAWING NO	EDAM
LEE G.H.				CODE NO	
2023.12.07					
 L K HOIST CO., LTD.					

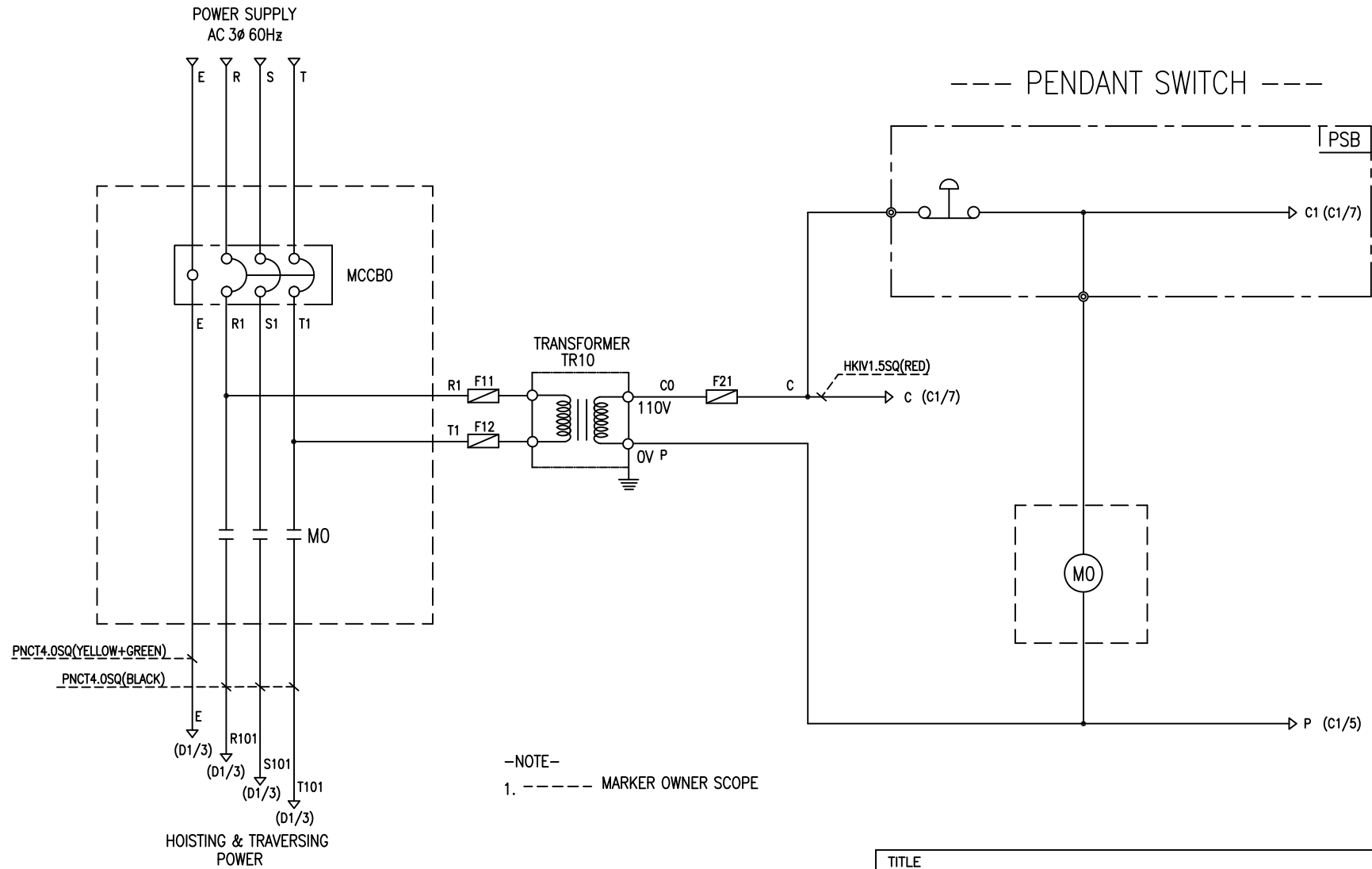

SPECIFICATION	NO FUSE BREAKER	MAGNET CONTACT	TRANSFORMER	FUZE		
SYMBOLS	MCCB0	M0	TR10	F11, F12, F21		
DESCRIPTION	220V	50A	GMC22	DMC-22	30VA	1A
	380V	30A				
	440V	20A				
	460V	20A				
	480V	20A				
MAKER	LS	LS	DONGA	YEONG DONG	-	

TITLE MAIN POWER & CONTROL CIRCUIT DIAGRAM						PROJECTION	
WORK NO 602		WORK NAME EDAM				SCALE N/S	Q' TY 1
DRAWN LEE.G.H	CHECKED	REVIEWED	APPROVED	MODEL EDAM	CODE NO		
2023.12.07							
L K HOIST CO., LTD.							

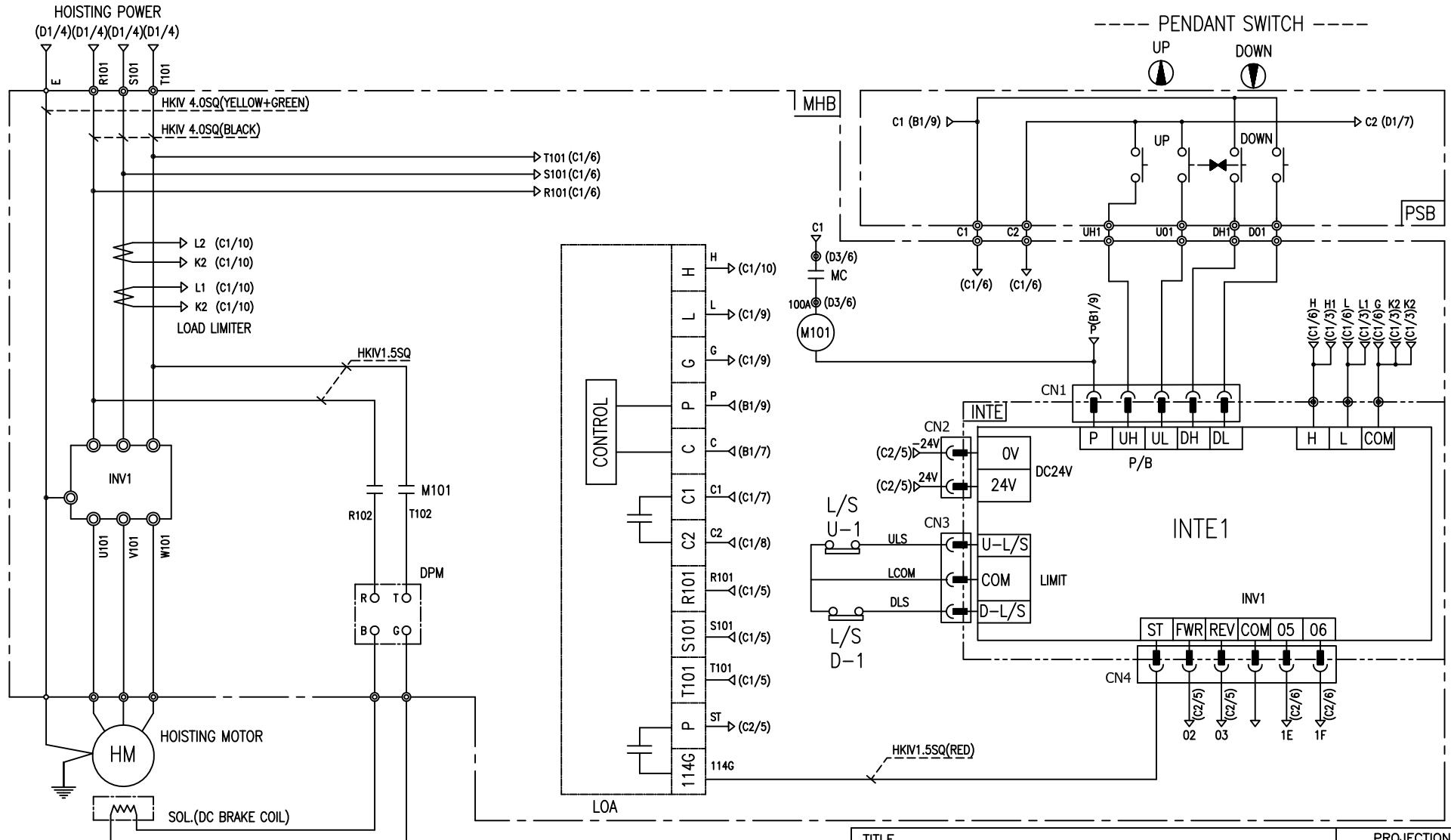

-NOTE-
 1. : Mechanical Interlock

SPECIFICATION	RELAY	LOAD LIMITER	SILICON RECTIFIER				HOIST MOTOR	
SYMBOLS	M101	LOA	DPM				HM	
DESCRIPTION	2A2B	LKDL-80	AC220V	AC380V	AC440V	AC460V	AC480V	3.5Kw * 4P
			DC99V	DC171V	DC198V	DC207V	DC216V	
MAKER	DAE-IL	YANG YEONG	SAMMUSCO				LK	

TITLE HOIST POWER & CONTROL CIRCUIT DIAGRAM						PROJECTION 	
WORK NO		WORK NAME				SCALE	
603		EDAM				Q' TY	
		220V, 380V, 440V, 460V, 480V				N/S	
DRAWN	CHECKED	REVIEWED	APPROVED	MODEL	EDAM		
LEE.G.H				CODE NO			
2023.12.07							
L K HOIST CO., LTD.							

HOIST CONTROL CIRCUIT

ADDRESS NO.

C2

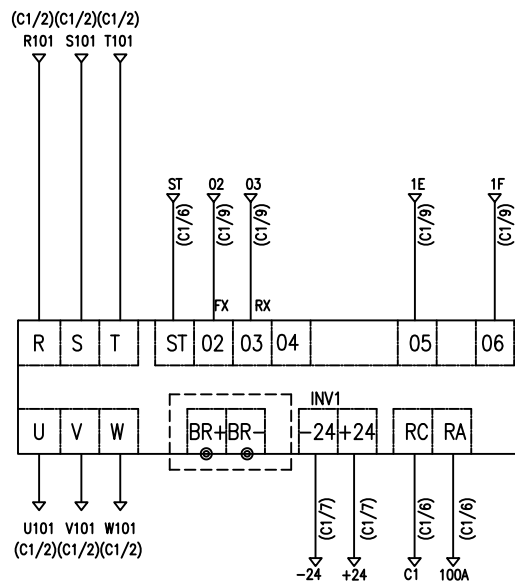

-NOTE-

1. - - - - : OPTION SCOPE

SPECIFICATION	INVERTER	BRAKING RESISTOR	
SYMBOLS	INV1	BR	
DESCRIPTION	LSLV-0040S100 4.0KW	200V	600W 33 OHM
		400V	600W 130 OHM
MAKER	LS	-	

TITLE						PROJECTION	
INVERTER CONTROL CIRCUIT DIAGRAM							
WORK NO	WORK NAME					SCALE	Q' TY
604	HOISTING					N/S	1
220V, 380V, 440V, 460V, 480V							
DRAWN	CHECKED	REVIEWED	APPROVED	MODEL	EDAM		
LEE.G.H				CODE NO			
2023.12.07							

TRAVERSING POWER CIRCUIT

TRAVERSING CONTROL CIRCUIT

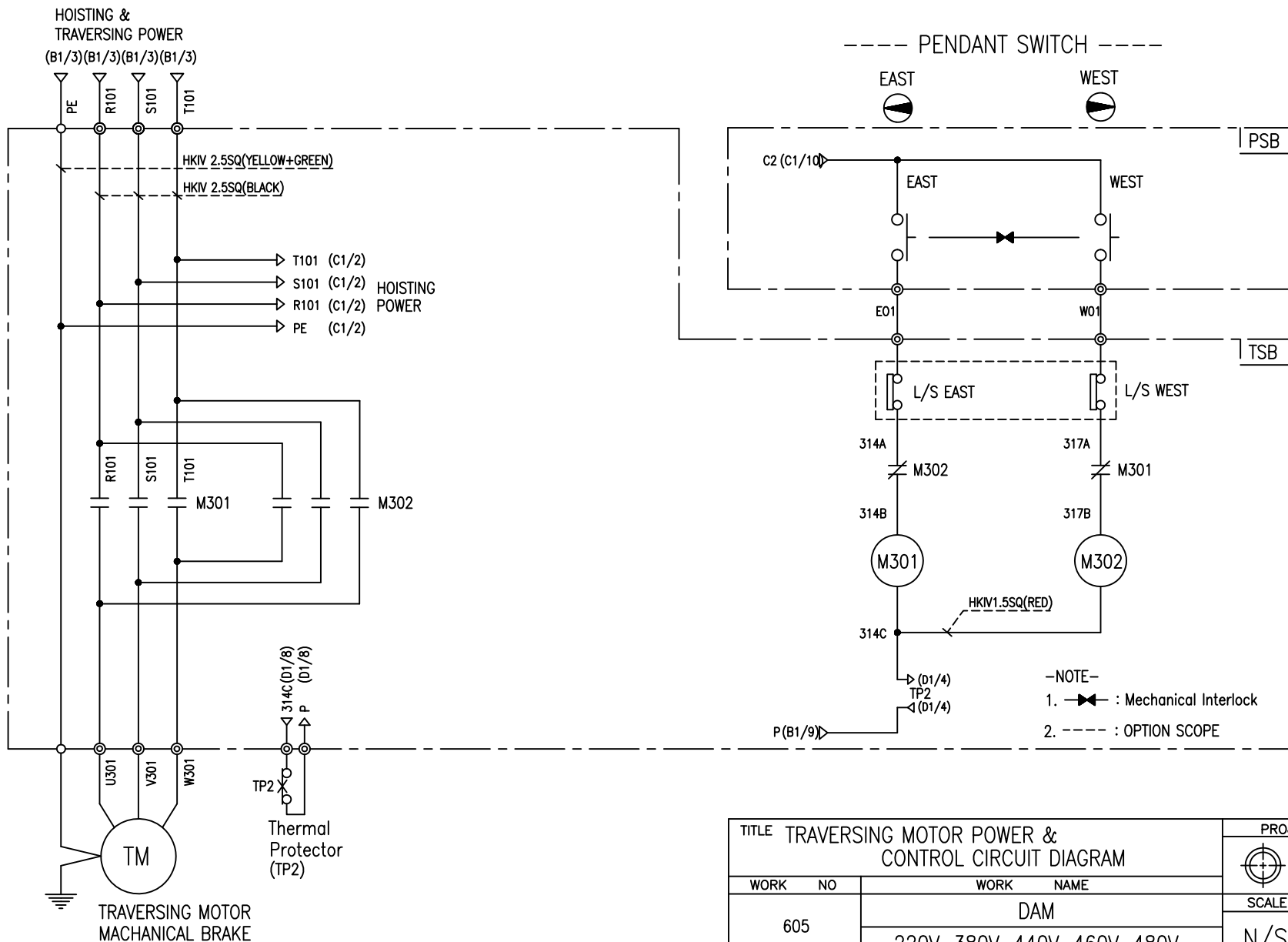

TITLE TRAVERSING MOTOR POWER & CONTROL CIRCUIT DIAGRAM						PROJECTION	
WORK NO 605						WORK NAME DAM	
220V, 380V, 440V, 460V, 480V						SCALE N/S	Q' TY 1
DRAWN LEE.G.H	CHECKED	REVIEWED	APPROVED	MODEL DAM			
2023.12.07							
LK L K HOIST CO., LTD.							

SPECIFICATION	MAGNET CONTACT	Thermal Protector	TRAVERSING MOTOR	
SYMBOLS	M301, M302	TP2	TM	
DESCRIPTION	DMC-12	17AM032	0.75KW*4P	0.4KW*6P
MAKER	DONG-A	Texas Instruments	LK	

TRAVERSING POWER CIRCUIT

TRAVERSING CONTROL CIRCUIT

ADDRESS NO. D1

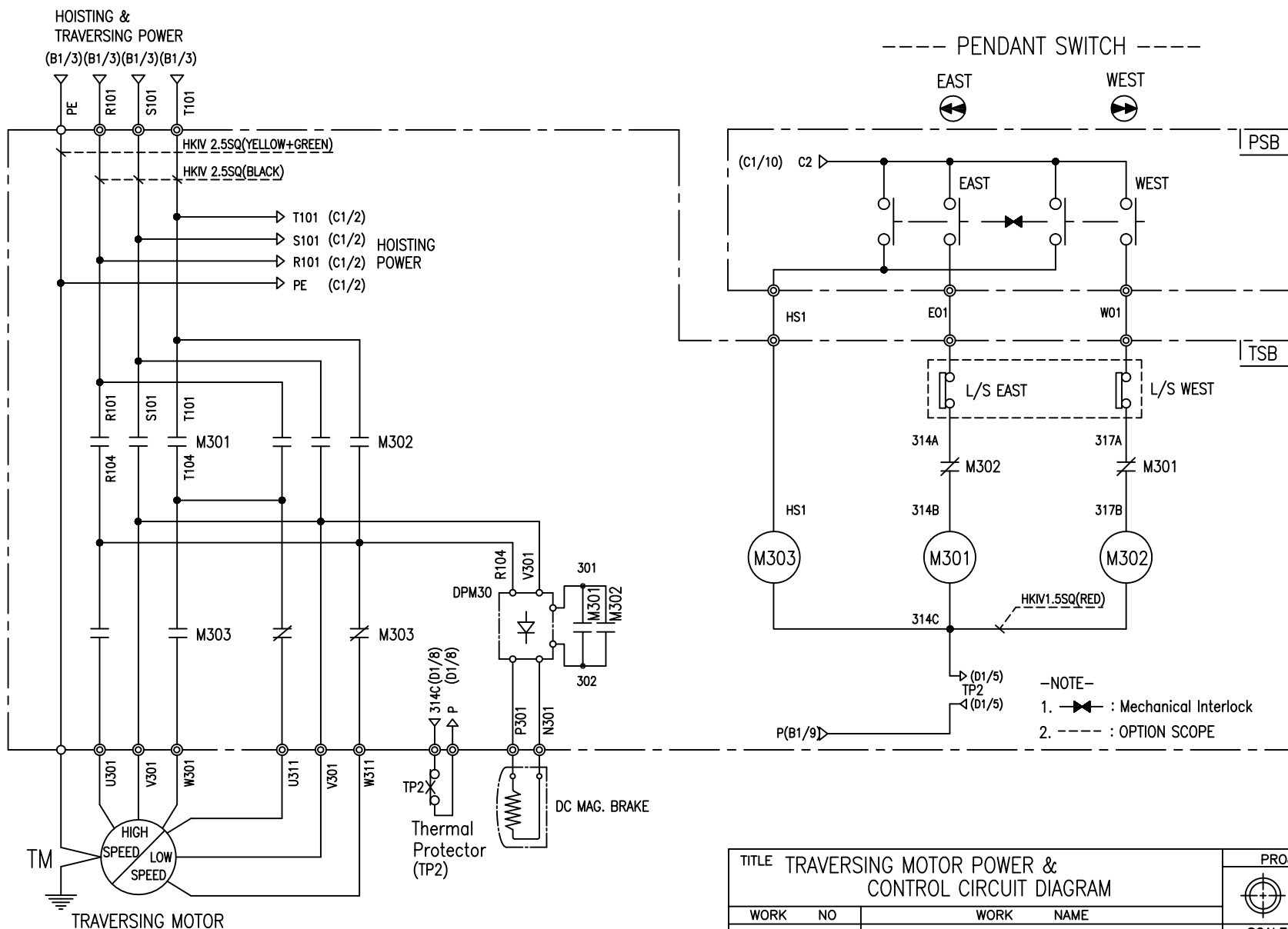

-NOTE-

1. : Mechanical Interlock
2. : OPTION SCOPE

TITLE TRAVERSING MOTOR POWER & CONTROL CIRCUIT DIAGRAM						PROJECTION	
WORK NO 606						WORK NAME DAM	
220V, 380V, 440V, 460V, 480V						SCALE N/S	Q' TY 1
DRAWN LEE.G.H	CHECKED	REVIEWED	APPROVED	MODEL	DAM		
2023.12.07							
L K HOIST CO., LTD.							

SPECIFICATION	MAGNET CONTACT	Thermal Protector	SILICON RECTIFIER					TRAVERSING MOTOR	
SYMBOLS	M301, M302	M303	DPM30					TM	
DESCRIPTION	DMC-12	DMC-12 (2A2B)	17AM032	AC220V	AC380V	AC440V	AC460V	AC480V	0.75/0.25KW*4/12P
				DC99V	DC171V	DC198V	DC207V	DC216V	
MAKER	DONG-A		Texas Instruments	YANG YEONG					LK

SCHEDULE OF TECHNICAL DATA

1. SERVICE	HOISTING
2. MANUFACTURE	LK HOIST CO. LTD
3. MOTOR MODEL NO	3.5 - 4 - 44
4. RATED POWER	3.5 KW × 4 P
5. RATED VOLTAGE AND FREQUENCY	440 V 60HZ
6. MOTOR TYPE	SQUIRREL CAGE ROTOR TYPE
7. RATING	30 MIN
8. LOCATION	IN-DOOR , OUTDOOR
9. INSULATION CLASS	B
10. DESIGN TEMPERATURE RISE (BY RESISTANCE)	80℃
11. FULL LOAD SPEED	1740 RPM
12. FULL LOAD CURRENT	8.6 A
13. STARTING CURRENT AT RATED VOLTAGE	46.4 A
14. MINIMUM STARTING VOLTAGE	396 V
15. EFFICIENCY AT 100% RATED LOAD	73.3 %
16. POWER FACTOR AT 100% RATED LOAD	72.8 %
17. STARTING TORQUE	245 %
18. TYPE OF ENCLOSURE	전폐형(IP-54)
19. TYPE OF BEARING	PL : 6205DD OPL : 6008ZZ
20. MOUNTING	VERTICAL
21. MAXIMUM AMBIENT TEMPURE	40℃
22. BEARING LUBRICATION	GREASE
23. STARTING METHOD	FULL VOLTAGE

SCHEDULE OF TECHNICAL DATA

1. SERVICE	TRAVERSING
2. MANUFACTURE	LK HOIST CO. LTD
3. MOTOR MODEL NO	0.75 - 4 - 44
4. RATED POWER	0.75 KW × 4 P
5. RATED VOLTAGE AND FREQUENCY	440 V 60HZ
6. MOTOR TYPE	SQUIRREL CAGE ROTOR TYPE
7. RATING	15 MIN
8. LOCATION	OUTDOOR
9. INSULATION CLASS	B
10. DESIGN TEMPERATURE RISE (BY RESISTANCE)	100℃
11. FULL LOAD SPEED	1670 RPM
12. FULL LOAD CURRENT	2.4 A
13. STARTING CURRENT AT RATED VOLTAGE	13.2 A
14. MINIMUM STARTING VOLTAGE	396 V
15. EFFICIENCY AT 100% RATED LOAD	65 %
16. POWER FACTOR AT 100% RATED LOAD	63 %
17. STARTING TORQUE	249 %
18. TYPE OF ENCLOSURE	전폐형
19. TYPE OF BEARING	PL : 6008DD OPL : 6207ZZ
20. MOUNTING	VERTICAL
21. MAXIMUM AMBIENT TEMPURE	40℃
22. BEARING LUBRICATION	GREASE
23. STARTING METHOD	FULL VOLTAGE

SCHEDULE OF TECHNICAL DATA

1. SERVICE	TRAVERSING
2. MANUFACTURE	LK HOIST CO. LTD
3. MOTOR MODEL NO	0.4 - 6 - 44
4. RATED POWER	0.4 KW × 6 P
5. RATED VOLTAGE AND FREQUENCY	440 V 60HZ
6. ROTOR TYPE	SQUIRREL CAGE ROTOR TYPE
7. RATING	15 MIN
8. LOCATION	OUTDOOR
9. INSULATION CLASS	B
10. DESIGN TEMPERATURE RISE (BY RESISTANCE)	80 °C
11. FULL LOAD SPEED	1140 RPM
12. FULL LOAD CURRENT	1.6 A
13. STARTING CURRENT AT RATED VOLTAGE	8.8 A
14. MINIMUM STARTING VOLTAGE	396 V
15. EFFICIENCY AT 100% RATED LOAD	65 %
16. POWER FACTOR AT 100% RATED LOAD	63 %
17. STARTING TORQUE	250 %
18. TYPE OF ENCLOSURE	TENV
19. TYPE OF BEARING	PL : 6202DD OPL : 6204DD
20. MOUNTING	VERTICAL
21. MAXIMUM AMBIENT TEMPERATURE	40°C
22. BEARING LUBRICATION	GREASE
23. STARTING METHOD	FULL VOLTAGE

SCHEDULE OF TECHNICAL DATA

1. SERVICE	TRAVERSING
2. MANUFACTURE	LK HOIST CO. LTD
3. MOTOR MODEL NO	0.75/0.25 - 4/12 - 44
4. RATED POWER	0.75/0.25 KW × 4/12 P
5. RATED VOLTAGE AND FREQUENCY	440 V 60HZ
6. MOTOR TYPE	SQUIRREL CAGE ROTOR TYPE
7. RATING	15 MIN
8. LOCATION	OUTDOOR
9. INSULATION CLASS	B
10. DESIGN TEMPERATURE RISE (BY RESISTANCE)	90 °C
11. FULL LOAD SPEED	1670 / 550 RPM
12. FULL LOAD CURRENT	2.4 / 1.5 A
13. STARTING CURRENT AT RATED VOLTAGE	13.2 / 8.25 A
14. MINIMUM STARTING VOLTAGE	396 V
15. EFFICIENCY AT 100% RATED LOAD	65 / 48 %
16. POWER FACTOR AT 100% RATED LOAD	63 / 46 %
17. STARTING TORQUE	250 / 243 %
18. TYPE OF ENCLOSURE	TENV
19. TYPE OF BEARING	PL : 6204DD OPL : 6205ZZ
20. MOUNTING	VERTICAL
21. MAXIMUM AMBIENT TEMPERATURE	40°C
22. BEARING LUBRICATION	GREASE
23. STARTING METHOD	FULL VOLTAGE