

ON OMD

L K HOIST

NO	DESCRIPTION	SIZE	MAT' L	Q' TY	WT (kg)	REMARKS

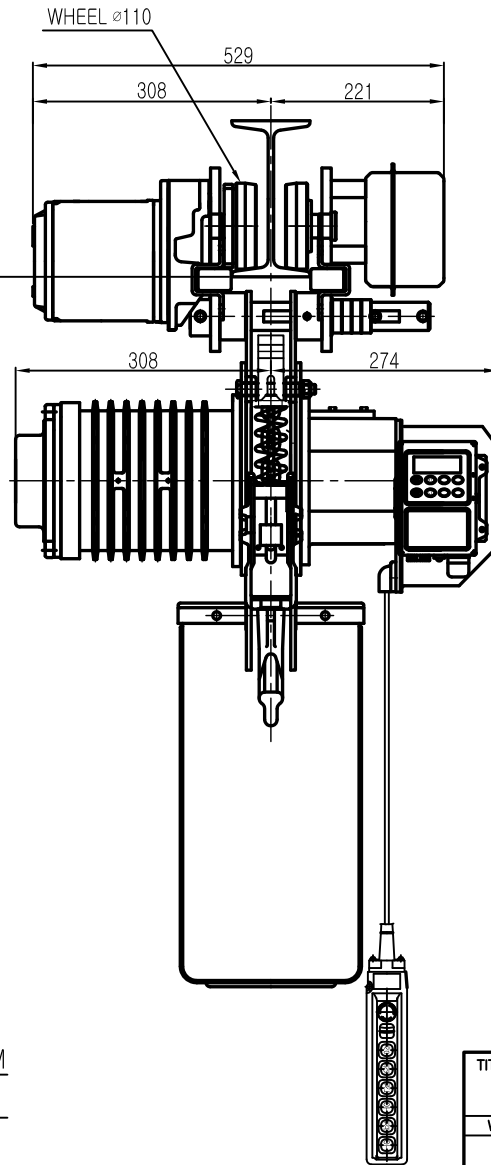
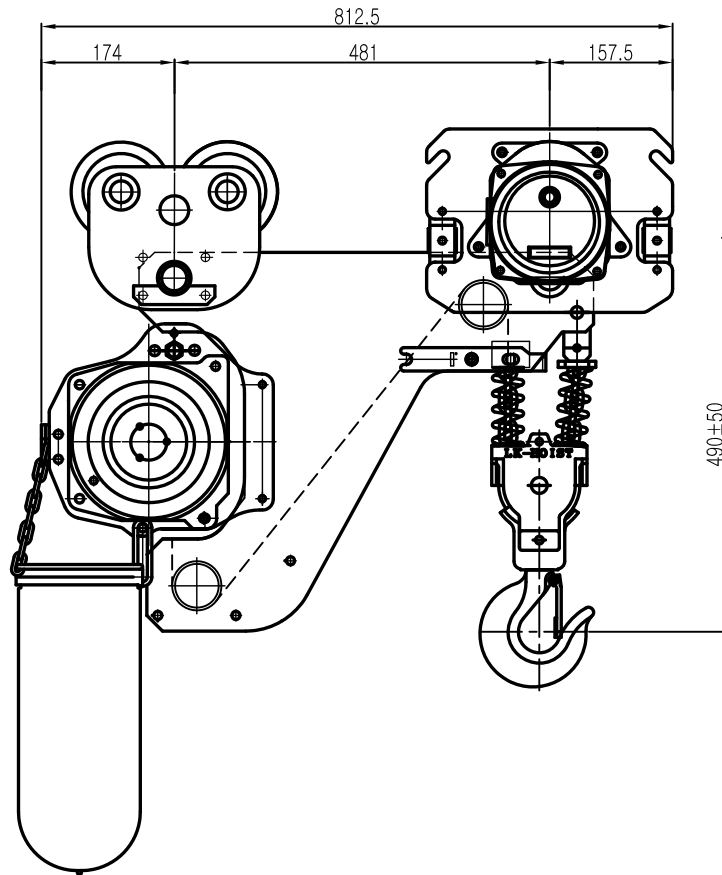

SPECIFICATION

		LK-SHDAM-1.9W		
RATED LOAD (TON)		1.9		
TESTING LOAD (TON)		2.375		
LIFTING HEIGHT (M)		50		
HOISTING	SPEED (M/MIN)	4.1		
	MOTOR (KW)	1.8kw x 4p		
TRAVERSING	SPEED (M/MIN)	21	14	21/7
	MOTOR (KW)	0.75kw x 4p	0.4kw x 6p	0.75/0.25kw x 4/12p
POWER SUPPLY		AC220,380,440,460,480Vx3ø x 60 Hz		
OPERATING METHOD		P.B type ON . FL		
LOAD CHAIN		ø7.1 X 21 (2FALL)		
WEIGHT (KG)		286		
I-BEAM 적용폭		100 ~ 190MM		

적용 I-BEAM)

- 1) 지점간 거리: I-200X100X7/10 - 3.0M
- 2) 지점간거리 : I-250X125X7.5/12.5-5.0M
- 3) 지점간거리 : I-300X150X10/18.5-7.5M
- 4) 지점간거리 : I-450X175X13/26-12M
- 5) 지점간거리 : I-600X190X13/25-15M

NOTE)

- 1)점검 설비를 갖출 것
- 2)인허가 서류를 완성감사시 제출 할 것

TITLE		ELECTRIC CHAIN HOIST			PROJECTION	
WORK NO		WORK NAME				
DRAWN		LK-SHDAM-1.9W			SCALE	Q' TY
					N S	1
	CHECKED	REVIEWED	APPROVED	DRAWING NO		
김 창 기				CORD NO		
2010.08.01						

REV.NO	DATE	REVISION	DESCRIPTION	DRAWN	CHECKED	APPROVED

L K HOIST CO., LTD.

ON GMD

L K HOIST

NO	DESCRIPTION	SIZE	MAT'L	Q'TY	WT (kg)	REMARKS

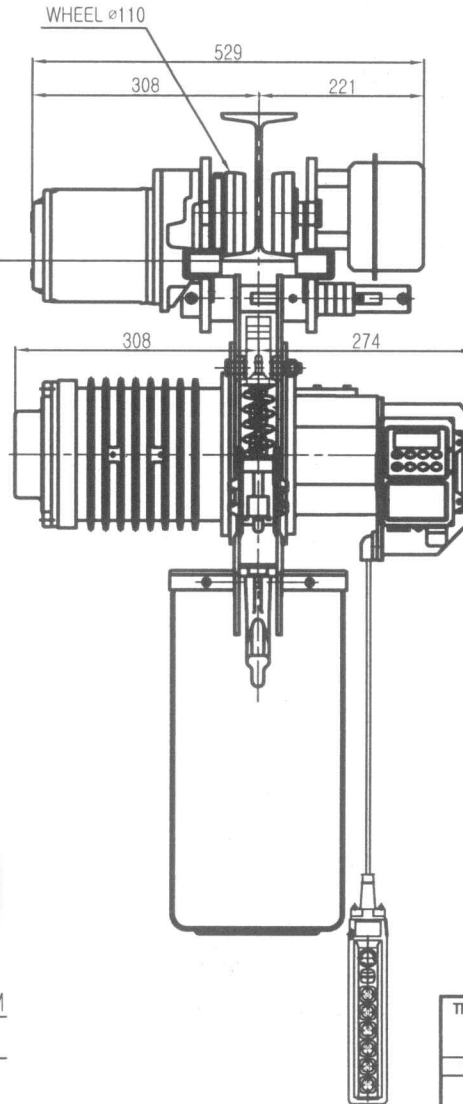
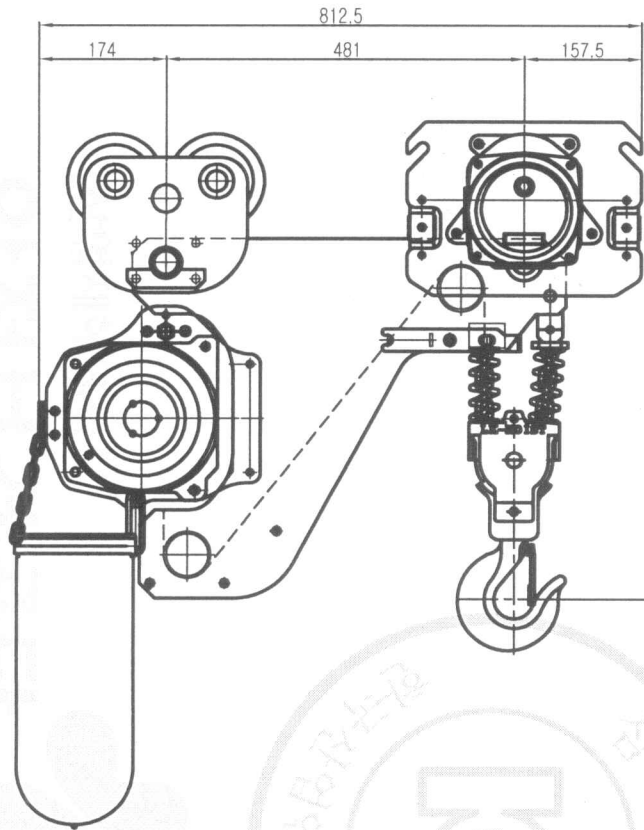

SPECIFICATION

		LK-SHDAM-1.9W		
RATED LOAD (TON)	1.9			
TESTING LOAD (TON)	2.375			
LIFTING HEIGHT (M)	50			
HOISTING	SPEED (M/MIN)	4.1		
	MOTOR (KW)	1.8kw x 4p		
TRAVERSING	SPEED (M/MIN)	21	14	21/7
	MOTOR (KW)	0.75kw x 4p	0.4kw x 6p	0.75/0.25kw x 4/12p
POWER SUPPLY	AC220.380.440.460.480Vx3ø x 60 Hz			
OPERATING METHOD	P.B type ON . FL			
LOAD CHAIN	ø7.1 X 21 (2FALL)			
WEIGHT (KG)	286			
I-BEAM 적용폭	100 ~ 190MM			

적용 I-BEAM)

- 1) 지점간 거리: I-200X100X7/10 - 3.0M
- 2) 지점간거리 : I-250X125X7.5/12.5-5.0M
- 3) 지점간거리 : I-300X150X10/18.5-7.5M
- 4) 지점간거리 : I-450X175X13/26-12M
- 5) 지점간거리 : I-600X190X13/25-15M

NOTE)

- 1)점검 설비를 갖출 것
- 2)인허가 서류를 완성검사시 제출 할 것

REV.NO	DATE	REVISION	DESCRIPTION	DRAWN	CHECKED	APPROVED

TITLE				PROJECTION	
ELECTRIC CHAIN HOIST					
WORK NO	WORK NAME			SCALE	Q' TY
	LK-SHDAM-1.9W			N S	1
DRAWN	CHECKED	REVIEWED	APPROVED	DRAWING NO	CORD NO
김 창 기					
2010.08.01					
L K HOIST CO., LTD.					

물범복제 및 배포금지