

POWER CIRCUIT
TRAVELLING POWER SUPPLY SYSTEM

ADDRESS NO.
A1



-NOTE-

- 1. - - - - MARKED OWNER SCOPE
- 2. ———— MARKED CRANE MAKER SCOPE

TITLE MAIN POWER CIRCUIT DIAGRAM1				PROJECTION 	
WORK NO 601	WORK NAME SHDAM			SCALE 1/1	Q' TY 1
DRAWN LEE G.H. 2010.07.30	CHECKED	REVIEWED	APPROVED	DRAWING NO SHDAM	CODE NO
L K HOIST CO., LTD.					



-NOTE-

1. ----- MARKER OWNER SCOPE
2. 24V인 경우 F21는 3A 적용

SPECIFICATION	NO FUSE BREAKER	MAGNET CONTACT	TRANSFORMER	FUZE	
SYMBOLS	MCCBO	MO	TR10	F11, F12, F21	
DESCRIPTION	220V	30A	30VA	1A	
	380V	15A			
	440V	15A			
	460V	15A			
	480V	15A			
MAKER	LS	LS	DONGA	LK	-

TITLE MAIN POWER & CONTROL CIRCUIT DIAGRAM						PROJECTION 	
WORK NO	WORK NAME					SCALE	Q' TY
602	SHDAM					1/1	1
220V, 380V, 440V, 460V, 480V							
DRAWN	CHECKED	REVIEWED	APPROVED	MODEL	SHDAM		
LEE.G.H							
2010.07.30				CODE NO			
L K HOIST CO., LTD.							

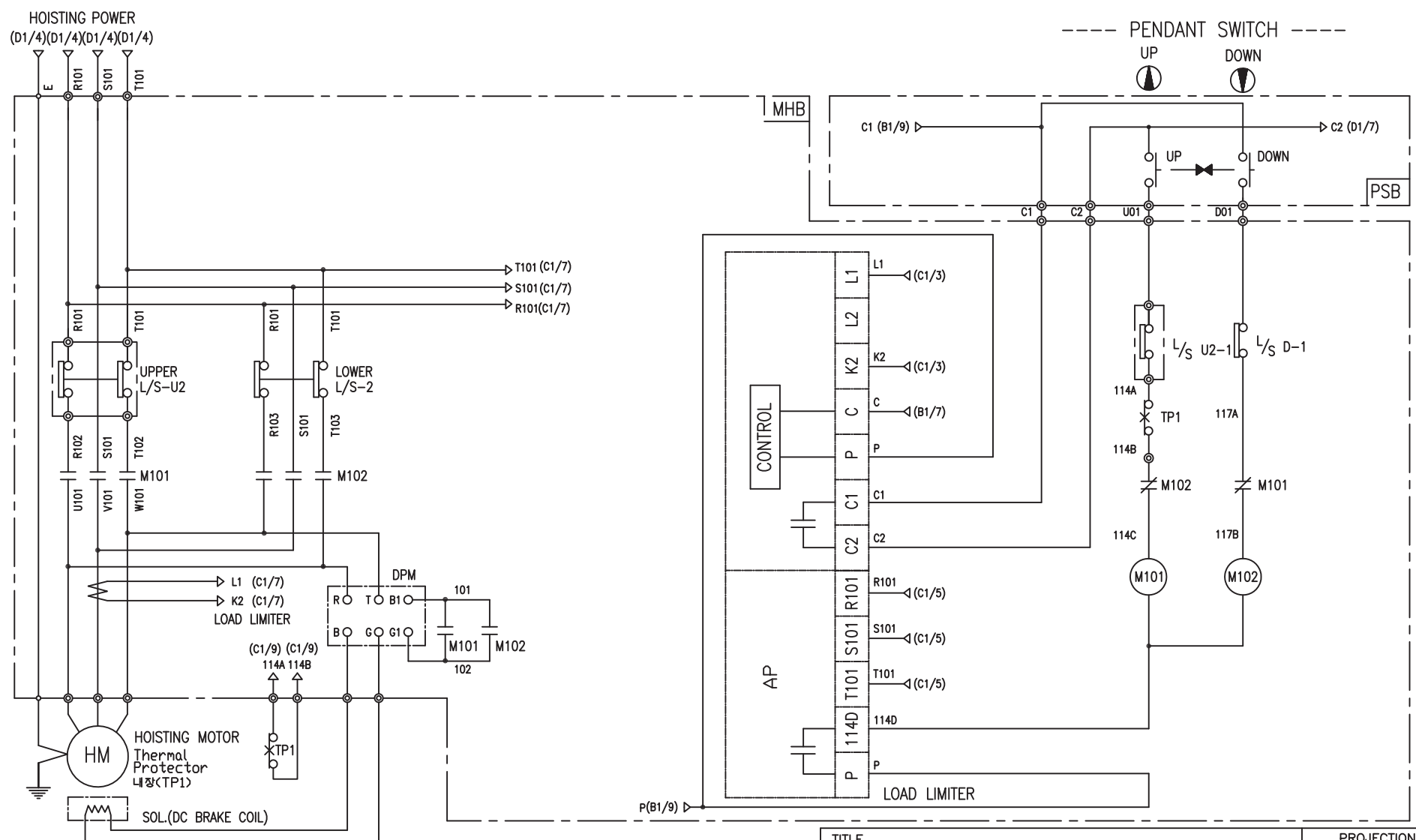

-NOTE-
 1. : Mechanical Interlock

SPECIFICATION	MAGNET CONTACT	LOAD LIMITER	SILICON RECTIFIER				Thermal Protector	HOIST MOTOR	
SYMBOLS	M101, M102	-	DPM				TP1	HM	
DESCRIPTION	DMC-12	GMC-12	LKDL-601	AC220V	AC440V	AC460V	AC480V	17AM032	1.8Kw * 4P
				DC99V	DC198V	DC207V	DC216V		
MAKER	DONG-A	LS	LK	LK				Texas Instruments	LK

TITLE						PROJECTION	
HOIST POWER & CONTROL CIRCUIT DIAGRAM							
WORK NO	WORK NAME					SCALE	Q' TY
603	SHDAM					1/1	1
220V, 440V, 460V, 480V							
DRAWN	CHECKED	REVIEWED	APPROVED	MODEL	SHDAM		
LEE.G.H							
2010.07.30				CODE NO			
L K HOIST CO., LTD.							

TRAVERSING POWER CIRCUIT

TRAVERSING CONTROL CIRCUIT

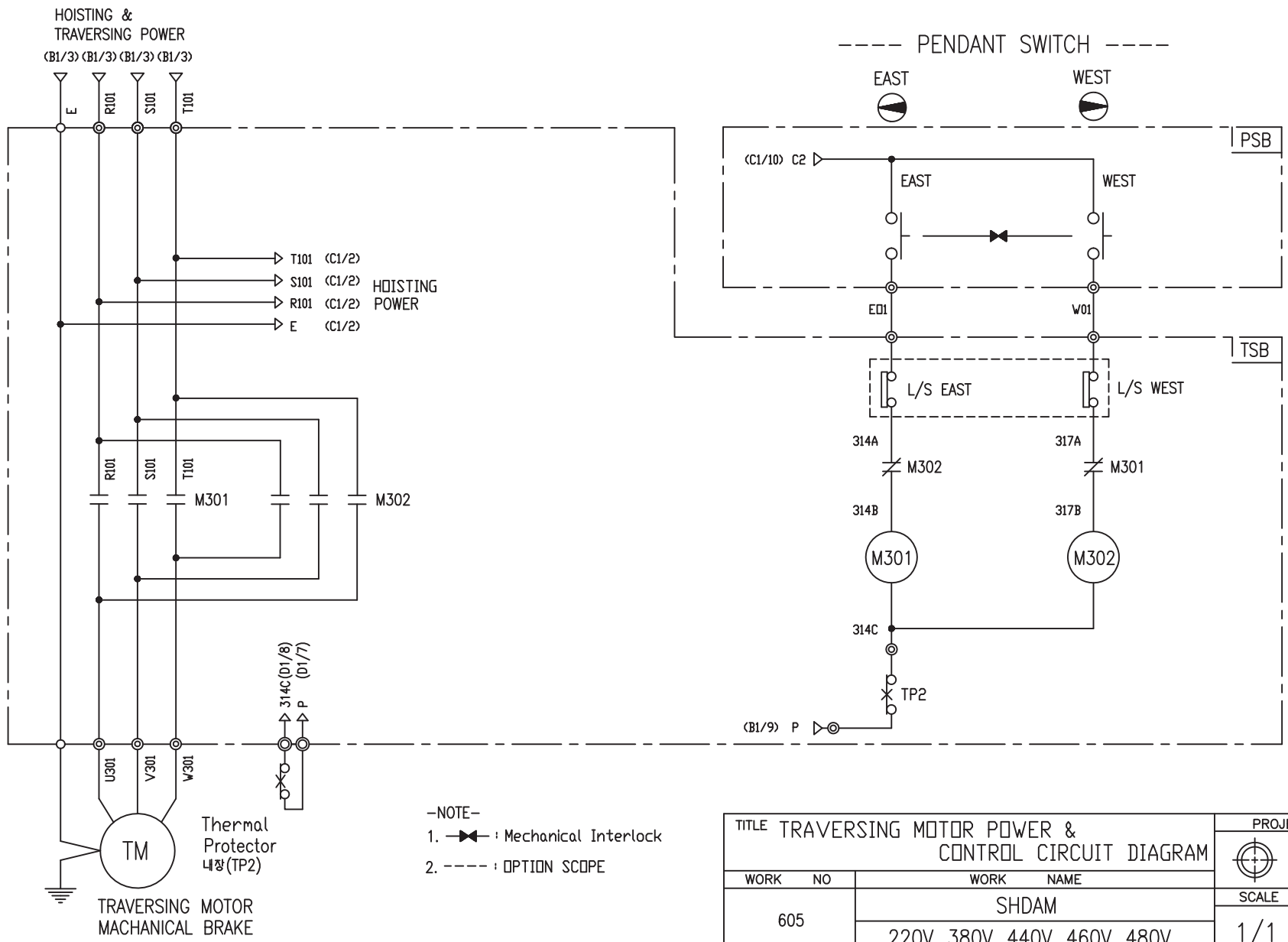

SPECIFICATION	MAGNET CONTACT	Thermal Protector	TRAVERSING MOTOR
SYMBOLS	M301, M302	TP2	TM
DESCRIPTION	GMC12 DMC12	17AM032	0.4KW *4P 0.3KW *6P
MAKER	LS DONGA	Texas Instruments	LK

TITLE TRAVERSING MOTOR POWER & CONTROL CIRCUIT DIAGRAM						PROJECTION	
WORK NO. 605						WORK NAME SHDAM	
220V, 380V, 440V, 460V, 480V						SCALE 1/1	Q' TY 1
DRAWN LEE.G.H	CHECKED	REVIEWED	APPROVED	MODEL SHDAM			
2010.07.30				CODE NO			
L K HOIST CO., LTD.							

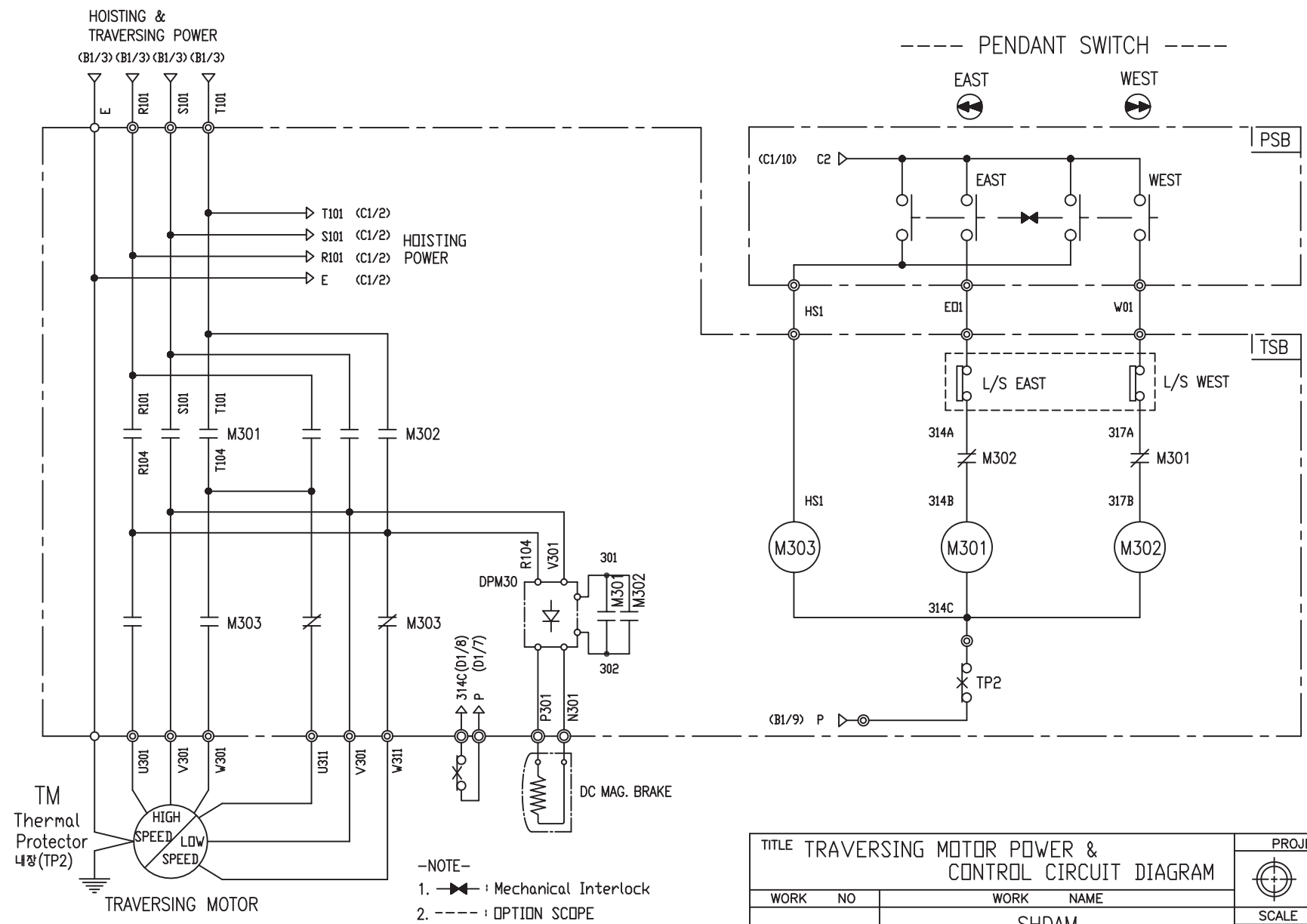

TITLE TRAVERSING MOTOR POWER & CONTROL CIRCUIT DIAGRAM						PROJECTION	
WORK NO 606						WORK NAME SHDAM	
220V, 380V, 440V, 460V, 480V						SCALE 1/1	Q' TY 1
DRAWN LEE.G.H	CHECKED	REVIEWED	APPROVED	MODEL	SHDAM		
2010.07.30				CODE NO			
LK L K HOIST CO., LTD.							

SPECIFICATION	MAGNET CONTACT		Thermal Protector	SILICON RECTIFIER					TRAVERSING MOTOR
SYMBOLS	M301, M302, M303		TP2	DPM30					TM
DESCRIPTION	GMC12	DMC12	17AM032	AC220V	AC380V	AC440V	AC460V	AC480V	0.4/0.14KW *4/12P
MAKER	LS	DONGA	Texas Instruments	DC99V	DC171V	DC198V	DC207V	DC216V	LK

SCHEDULE OF TECHNICAL DATA

1. SERVICE	HOISTING
2. MANUFACTURE	LK HOIST CO. LTD
3. MOTOR MODEL NO	1.8 - 4 - 46
4. RATED POWER	1.8 KW × 4 P
5. RATED VOLTAGE AND FREQUENCY	460 V 60HZ
6. MOTOR TYPE	SQUIRREL CAGE ROTOR TYPE
7. RATING	30 MIN
8. LOCATION	IN-DOOR , OUTDOOR
9. INSULATION CLASS	B
10. DESIGN TEMPERATURE RISE (BY RESISTANCE)	80℃
11. FULL LOAD SPEED	1740 RPM
12. FULL LOAD CURRENT	4.5 A
13. STARTING CURRENT AT RATED VOLTAGE	22.2 A
14. MINIMUM STARTING VOLTAGE	397 V
15. EFFICIENCY AT 100% RATED LOAD	72.4 %
16. POWER FACTOR AT 100% RATED LOAD	69.4 %
17. STARTING TORQUE	246 %
18. TYPE OF ENCLOSURE	전폐형
19. TYPE OF BEARING	PL : 6008DD OPL : 6207ZZ
20. MOUNTING	VERTICAL
21. MAXIMUM AMBIENT TEMPURE	40℃
22. BEARING LUBRICATION	GREASE
23. STARTING METHOD	FULL VOLTAGE

SCHEDULE OF TECHNICAL DATA

1. SERVICE	TRAVERSING
2. MANUFACTURE	LK HOIST CO. LTD
3. MOTOR MODEL NO	0.4 - 4 - 46
4. RATED POWER	0.4 KW × 4 P
5. RATED VOLTAGE AND FREQUENCY	460 V 60HZ
6. ROTOR TYPE	SQUIRREL CAGE ROTOR TYPE
7. RATING	15 MIN
8. LOCATION	IN-DOOR , OUTDOOR
9. INSULATION CLASS	B
10. DESIGN TEMPERATURE RISE (BY RESISTANCE)	100℃
11. FULL LOAD SPEED	1710 RPM
12. FULL LOAD CURRENT	1.43 A
13. STARTING CURRENT AT RATED VOLTAGE	6.6 A
14. MINIMUM STARTING VOLTAGE	405 V
15. EFFICIENCY AT 100% RATED LOAD	59 %
16. POWER FACTOR AT 100% RATED LOAD	59.5 %
17. STARTING TORQUE	249 %
18. TYPE OF ENCLOSURE	전폐형
19. TYPE OF BEARING	PL : 6202DD OPL : 6004ZZ
20. MOUNTING	VERTICAL
21. MAXIMUM AMBIENT TEMPERATURE	40℃
22. BEARING LUBRICATION	GREASE
23. STARTING METHOD	FULL VOLTAGE

SCHEDULE OF TECHNICAL DATA

1. SERVICE	TRAVERSING
2. MANUFACTURE	LK HOIST CO. LTD
3. MOTOR MODEL NO	0.3 - 6 - 46
4. RATED POWER	0.3 KW × 6 P
5. RATED VOLTAGE AND FREQUENCY	460 V 60HZ
6. ROTOR TYPE	SQUIRREL CAGE ROTOR TYPE
7. RATING	15 MIN
8. LOCATION	IN-DOOR , OUTDOOR
9. INSULATION CLASS	B
10. DESIGN TEMPERATURE RISE (BY RESISTANCE)	100℃
11. FULL LOAD SPEED	1140 RPM
12. FULL LOAD CURRENT	1.4 A
13. STARTING CURRENT AT RATED VOLTAGE	7.66 A
14. MINIMUM STARTING VOLTAGE	414 V
15. EFFICIENCY AT 100% RATED LOAD	53 %
16. POWER FACTOR AT 100% RATED LOAD	51 %
17. STARTING TORQUE	249 %
18. TYPE OF ENCLOSURE	전폐형
19. TYPE OF BEARING	PL : 6008DD OPL : 6207ZZ
20. MOUNTING	VERTICAL
21. MAXIMUM AMBIENT TEMPERATURE	40℃
22. BEARING LUBRICATION	GREASE
23. STARTING METHOD	FULL VOLTAGE

SCHEDULE OF TECHNICAL DATA

1. SERVICE	TRAVERSING
2. MANUFACTURE	LK HOIST CO. LTD
3. MOTOR MODEL NO	0.4/0.14 - 4/12 - 46
4. RATED POWER	0.4/0.14 KW × 4/12 P
5. RATED VOLTAGE AND FREQUENCY	460 V 60HZ
6. MOTOR TYPE	SQUIRREL CAGE ROTOR TYPE
7. RATING	15 MIN
8. LOCATION	IN-DOOR , OUTDOOR
9. INSULATION CLASS	B
10. DESIGN TEMPERATURE RISE (BY RESISTANCE)	100℃
11. FULL LOAD SPEED	1710 / 550 RPM
12. FULL LOAD CURRENT	1.43 / 0.94 A
13. STARTING CURRENT AT RATED VOLTAGE	7.1 / 4.7 A
14. MINIMUM STARTING VOLTAGE	414 V
15. EFFICIENCY AT 100% RATED LOAD	62 / 49 %
16. POWER FACTOR AT 100% RATED LOAD	56.5 / 41 %
17. STARTING TORQUE	230 / 231 %
18. TYPE OF ENCLOSURE	전폐형
19. TYPE OF BEARING	PL : 6008DD OPL : 6207ZZ
20. MOUNTING	VERTICAL
21. MAXIMUM AMBIENT TEMPURE	40℃
22. BEARING LUBRICATION	GREASE
23. STARTING METHOD	FULL VOLTAGE