

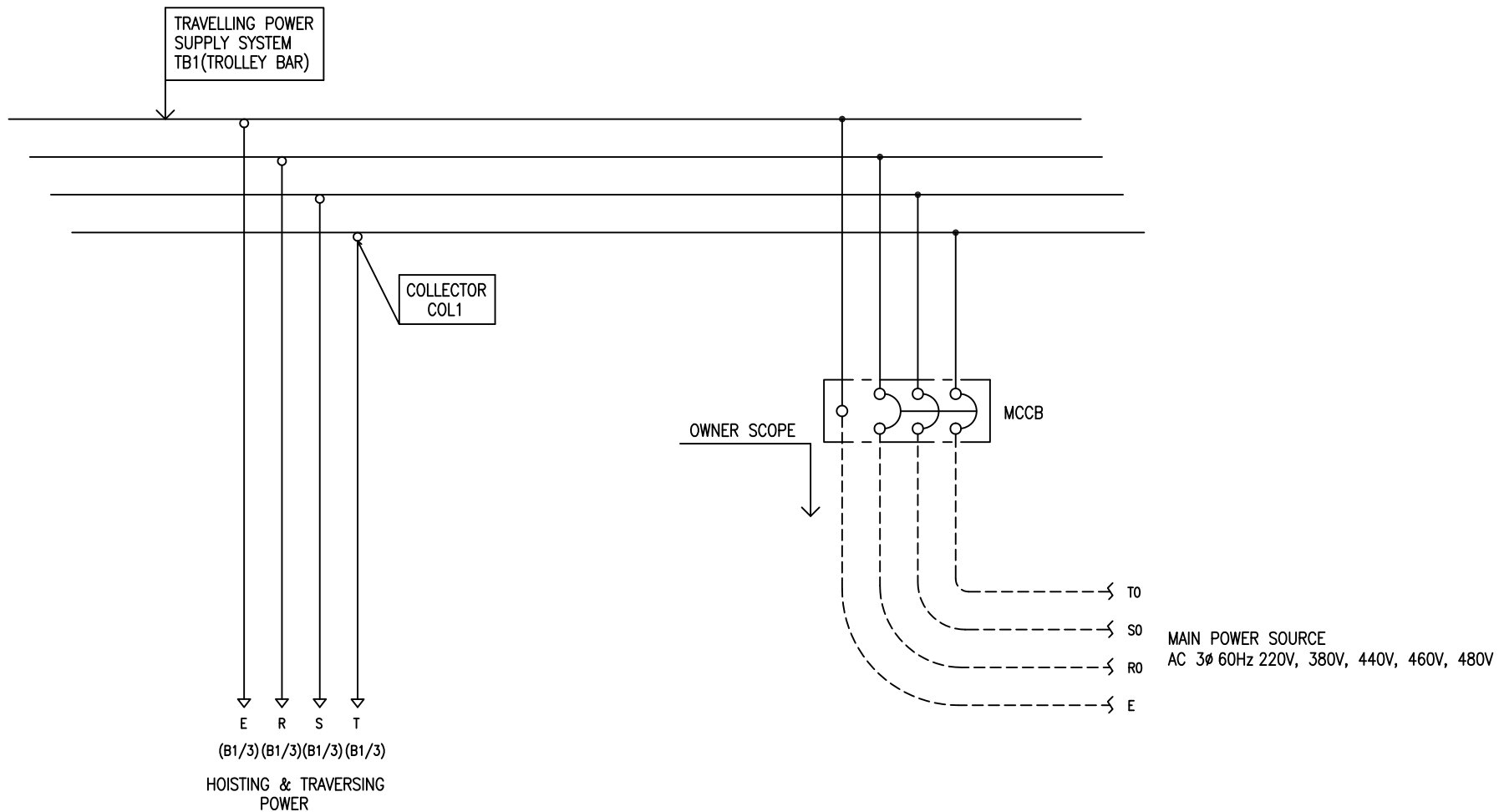

POWER CIRCUIT
TRAVELLING POWER SUPPLY SYSTEM

ADDRESS NO.
A1

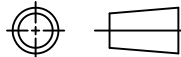

-NOTE-

- 1. - - - - MARKED OWNER SCOPE
- 2. ——— MARKED CRAIN MAKER SCOPE

TITLE MAIN POWER CIRCUIT DIAGRAM1				PROJECTION 	
WORK NO 601	WORK NAME DAM			SCALE N/S	Q' TY 1
DRAWN LEE G.H. 2010.07.30				CHECKED	REVIEWED
APPROVED				DRAWING NO DAM	CODE NO
 L K HOIST CO., LTD.					

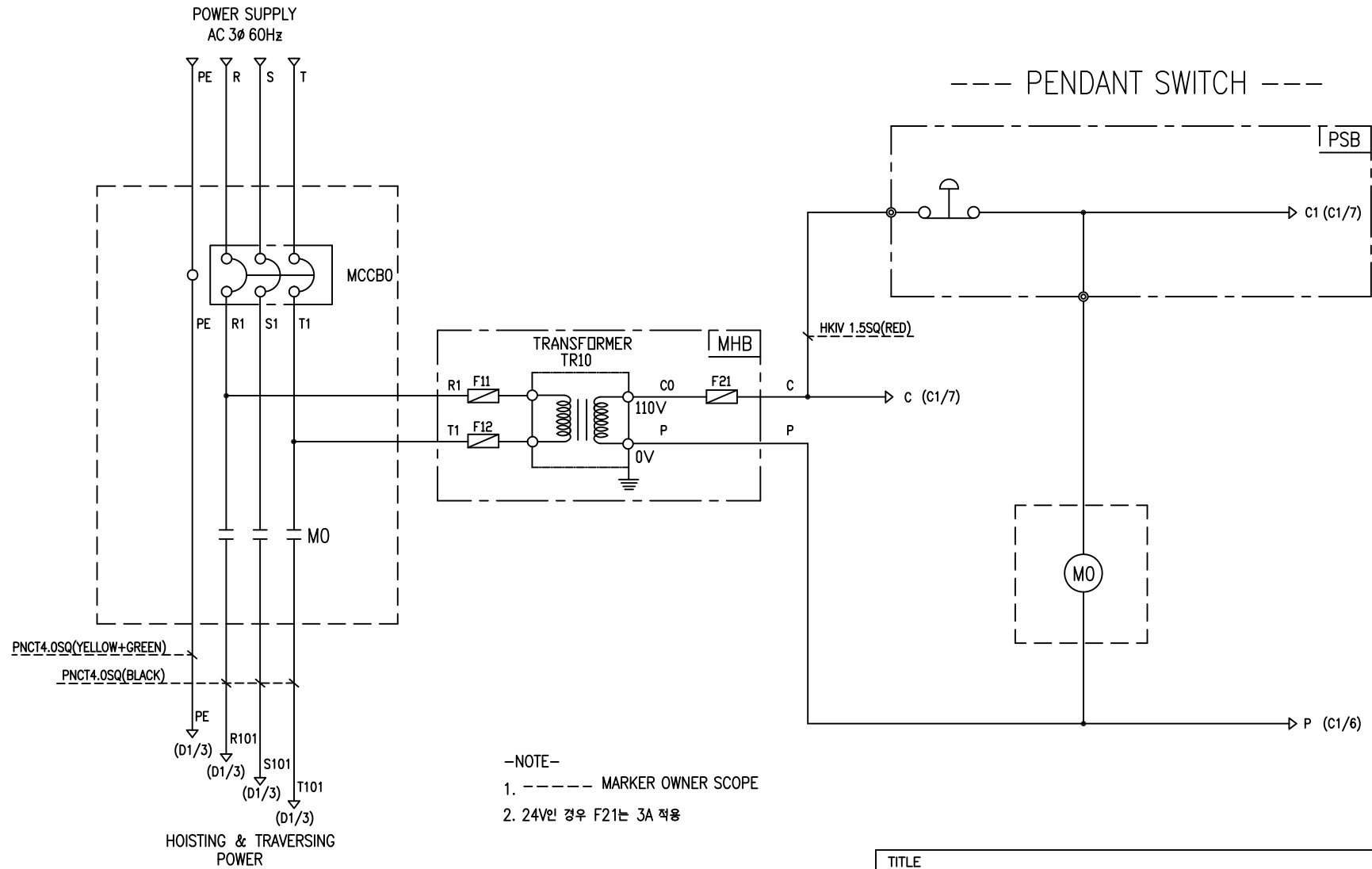

-NOTE-

1. ----- MARKER OWNER SCOPE
2. 24V인 경우 F21는 3A 적용

SPECIFICATION	NO FUSE BREAKER	MAGNET CONTACT	TRANSFORMER	FUZE
SYMBOLS	MCCBO	MO	TR10	F11, F12, F21
DESCRIPTION	220V	30A	30VA	1A
	380V	15A		
	440V	15A		
	460V	15A		
	480V	15A		
MAKER	LS	DONG-A	YEONG DONG	-

TITLE						PROJECTION	
MAIN POWER & CONTROL CIRCUIT DIAGRAM							
WORK NO	WORK NAME					SCALE	Q' TY
602	DAM					N/S	1
220V, 380V, 440V, 460V, 480V							
DRAWN	CHECKED	REVIEWED	APPROVED	MODEL	DAM		
LEE.G.H							
2010.07.30				CODE NO			
L K HOIST CO., LTD.							

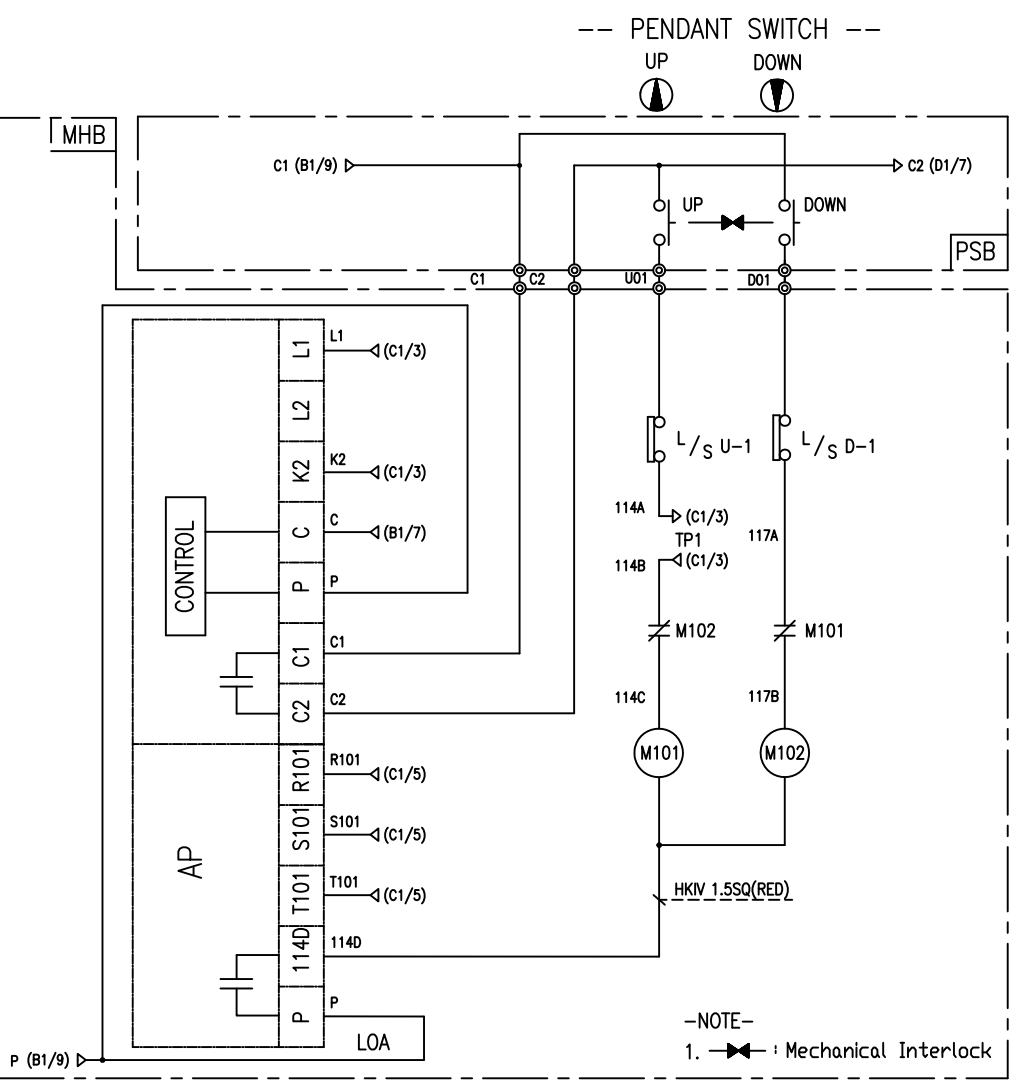
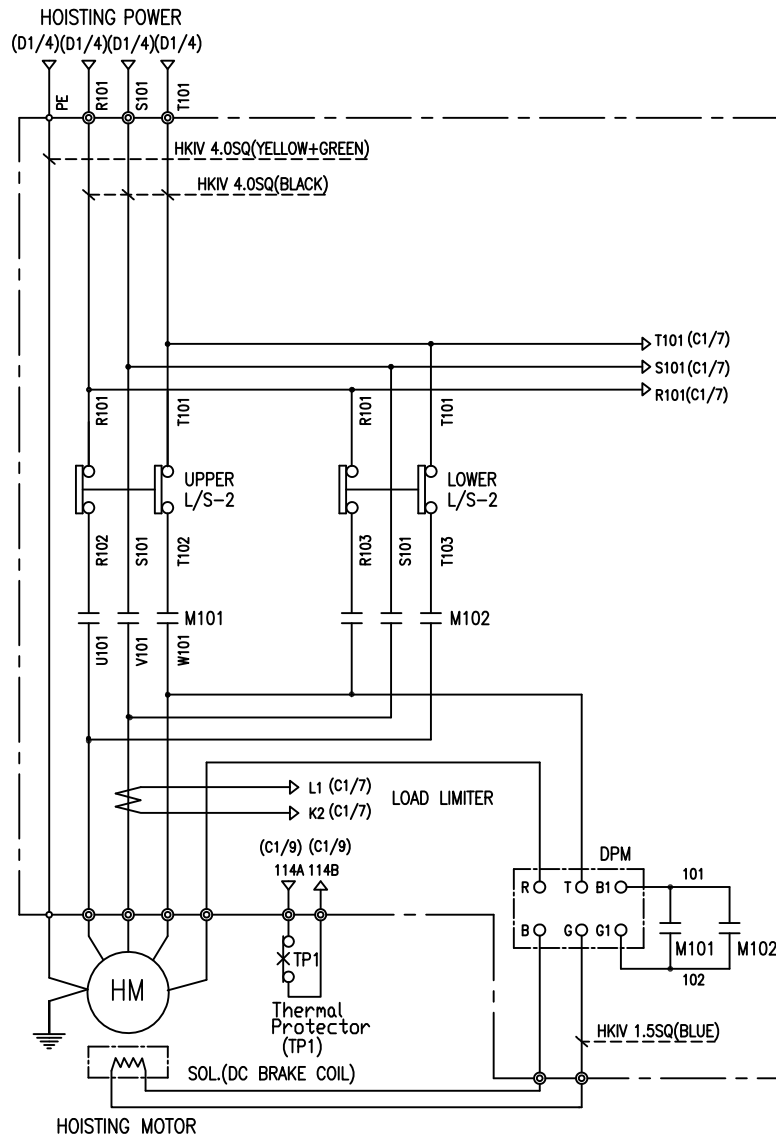

SPECIFICATION	MAGNET CONTACT	LOAD LIMITER	SILICON RECTIFIER	Thermal Protector	HOIST MOTOR
SYMBOLS	M101, M102	LOA	DPM	TP1	HM
DESCRIPTION	DMC-12	LKDL-60A	AC220V/DC99V	17AM032	1.8Kw * 4P
MAKER	DONG-A	YANG YEONG	YANG YEONG	Texas Instruments	LK

TITLE HOIST POWER & CONTROL CIRCUIT DIAGRAM						PROJECTION 	
WORK NO 604		WORK NAME DAM				SCALE N/S	Q' TY 1
DRAWN LEE.G.H	CHECKED	REVIEWED	APPROVED	MODEL DAM	CODE NO		
2010.07.30							
L K HOIST CO., LTD.							

TRAVERSING POWER CIRCUIT

TRAVERSING CONTROL CIRCUIT

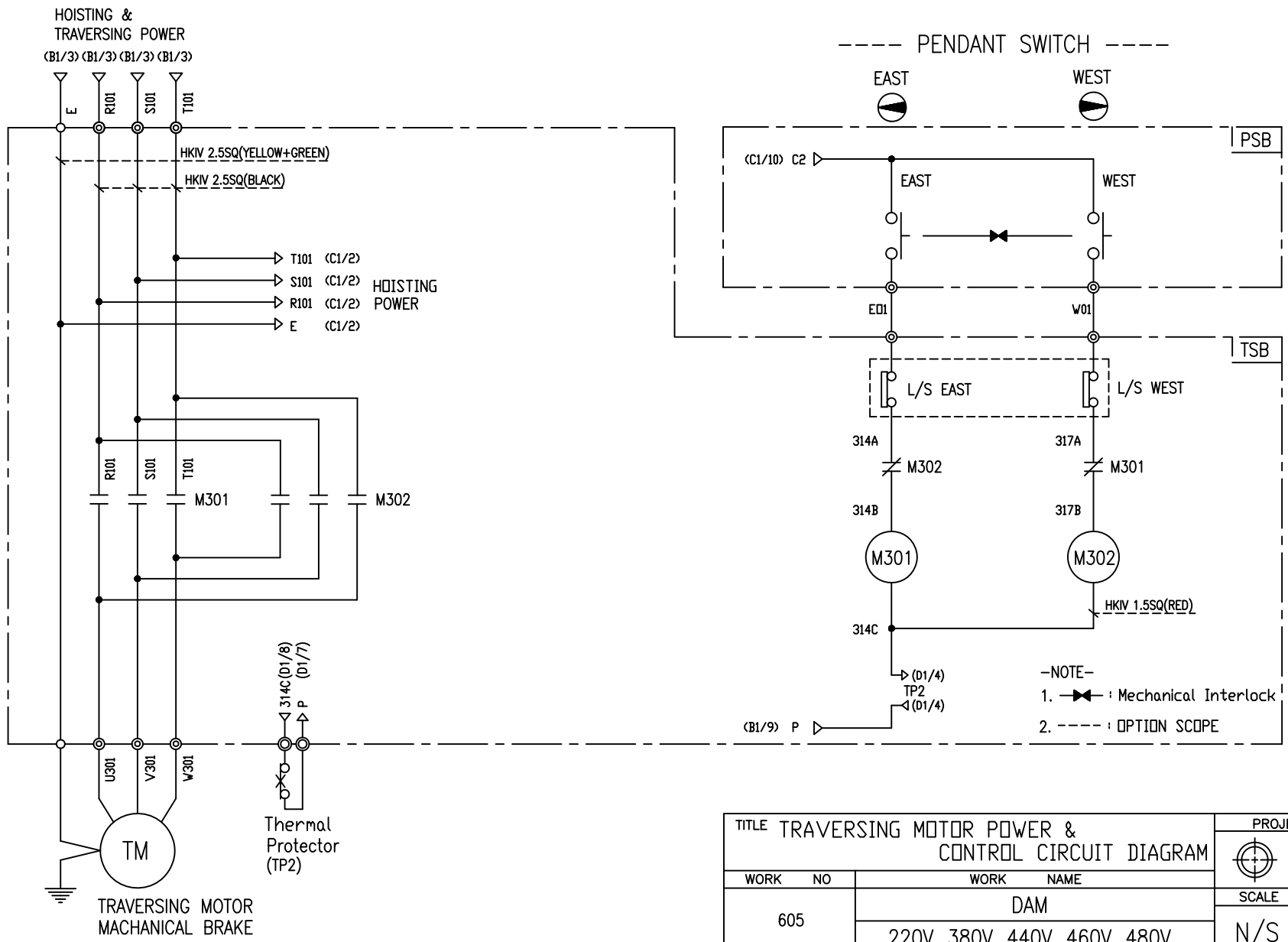

SPECIFICATION	MAGNET CONTACT	Thermal Protector	TRAVERSING MOTOR	
SYMBOLS	M301, M302	TP2	TM	
DESCRIPTION	DMC-12	17AM032	0.4KW*4P	0.3KW*6P
MAKER	DONG-A	Texas Instruments	LK	

TITLE TRAVERSING MOTOR POWER & CONTROL CIRCUIT DIAGRAM						PROJECTION	
WORK NO		WORK NAME					
605		DAM				SCALE	Q' TY
		220V, 380V, 440V, 460V, 480V				N/S	1
DRAWN	CHECKED	REVIEWED	APPROVED	MODEL	DAM		
LEE.G.H				CODE NO			
2010.07.30							
L K HOIST CO., LTD.							

TRAVERSING POWER CIRCUIT

TRAVERSING CONTROL CIRCUIT

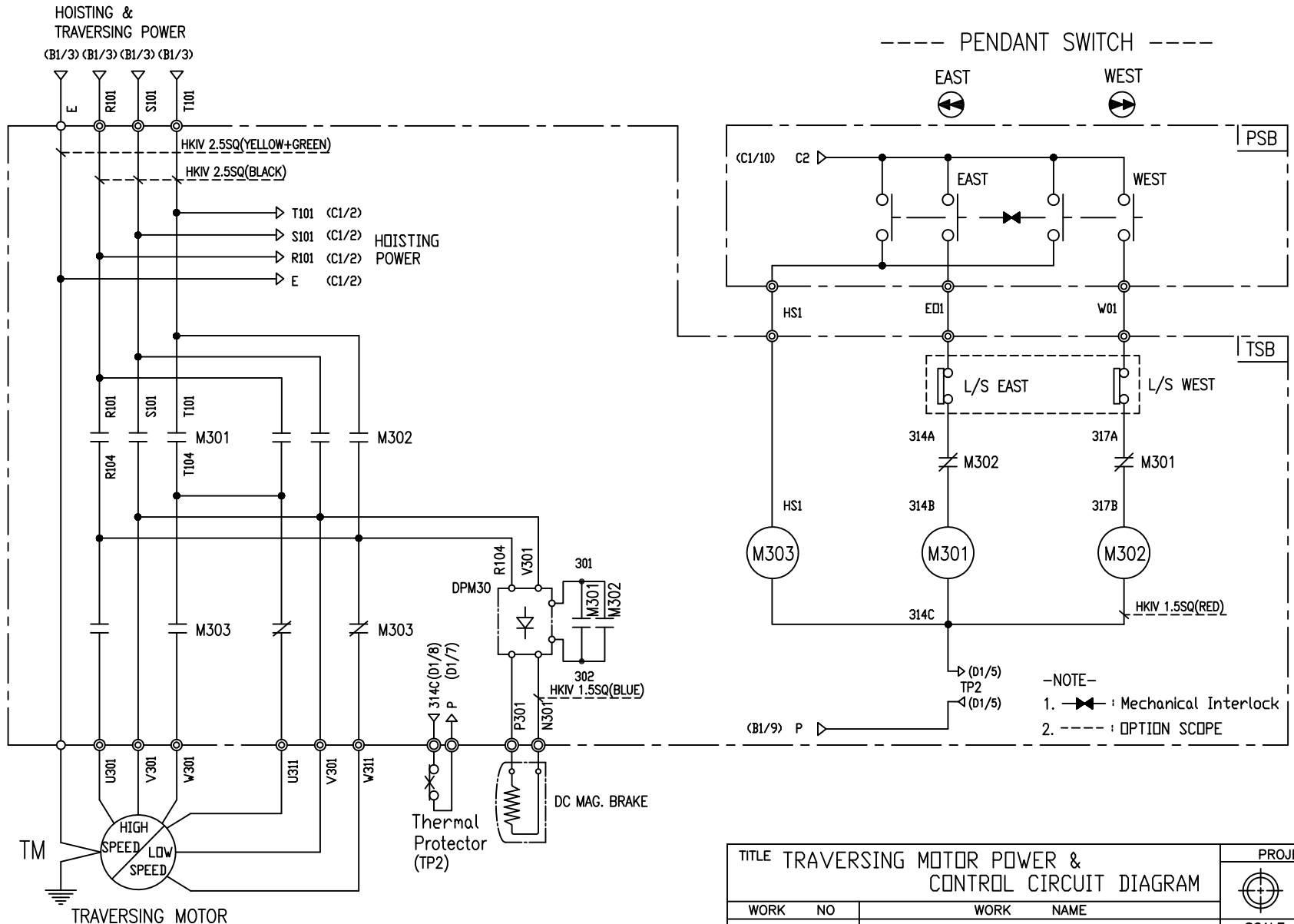

TITLE TRAVERSING MOTOR POWER & CONTROL CIRCUIT DIAGRAM						PROJECTION	
WORK NO 606						WORK NAME DAM	
220V, 380V, 440V, 460V, 480V						SCALE N/S	Q' TY 1
DRAWN LEE.G.H	CHECKED	REVIEWED	APPROVED	MODEL	DAM		
2010.07.30				CODE NO			
LK L K HOIST CO., LTD.							

SPECIFICATION	MAGNET CONTACT	Thermal Protector	SILICON RECTIFIER					TRAVERSING MOTOR	
SYMBOLS	M301, M302	M303	DPM30					TM	
DESCRIPTION	DMC-12	DMC-12 (2A2B)	17AM032	AC220V	AC380V	AC440V	AC460V	AC480V	0.4/0.14KW * 4/12P
MAKER	DONG-A		Texas Instruments	DC99V	DC171V	DC198V	DC207V	DC216V	LK

SCHEDULE OF TECHNICAL DATA

1. SERVICE	HOISTING
2. MANUFACTURE	LK HOIST CO. LTD
3. MOTOR MODEL NO	1.8 - 4 - 38
4. RATED POWER	1.8 KW × 4 P
5. RATED VOLTAGE AND FREQUENCY	380 V 60HZ
6. MOTOR TYPE	SQUIRREL CAGE ROTOR TYPE
7. RATING	30 MIN
8. LOCATION	IN-DOOR , OUTDOOR
9. INSULATION CLASS	B
10. DESIGN TEMPERATURE RISE (BY RESISTANCE)	80℃
11. FULL LOAD SPEED	1740 RPM
12. FULL LOAD CURRENT	5.4 A
13. STARTING CURRENT AT RATED VOLTAGE	26.9 A
14. MINIMUM STARTING VOLTAGE	342 V
15. EFFICIENCY AT 100% RATED LOAD	73.0 %
16. POWER FACTOR AT 100% RATED LOAD	69.4 %
17. STARTING TORQUE	246 %
18. TYPE OF ENCLOSURE	전폐형
19. TYPE OF BEARING	PL : 6008DD OPL : 6207ZZ
20. MOUNTING	VERTICAL
21. MAXIMUM AMBIENT TEMPURE	40℃
22. BEARING LUBRICATION	GREASE
23. STARTING METHOD	FULL VOLTAGE

SCHEDULE OF TECHNICAL DATA

1. SERVICE	TRAVERSING
2. MANUFACTURE	LK HOIST CO. LTD
3. MOTOR MODEL NO	0.4 - 4 - 38
4. RATED POWER	0.4 KW × 4 P
5. RATED VOLTAGE AND FREQUENCY	380 V 60HZ
6. ROTOR TYPE	SQUIRREL CAGE ROTOR TYPE
7. RATING	15 MIN
8. LOCATION	IN-DOOR , OUTDOOR
9. INSULATION CLASS	B
10. DESIGN TEMPERATURE RISE (BY RESISTANCE)	100℃
11. FULL LOAD SPEED	1710 RPM
12. FULL LOAD CURRENT	1.8 A
13. STARTING CURRENT AT RATED VOLTAGE	8.28 A
14. MINIMUM STARTING VOLTAGE	343 V
15. EFFICIENCY AT 100% RATED LOAD	59 %
16. POWER FACTOR AT 100% RATED LOAD	67.2 %
17. STARTING TORQUE	232 %
18. TYPE OF ENCLOSURE	전폐형
19. TYPE OF BEARING	PL : 6202DD OPL : 6004ZZ
20. MOUNTING	VERTICAL
21. MAXIMUM AMBIENT TEMPERATURE	40℃
22. BEARING LUBRICATION	GREASE
23. STARTING METHOD	FULL VOLTAGE

SCHEDULE OF TECHNICAL DATA

1. SERVICE	TRAVERSING
2. MANUFACTURE	LK HOIST CO. LTD
3. MOTOR MODEL NO	0.3 - 6 - 38
4. RATED POWER	0.3 KW × 6 P
5. RATED VOLTAGE AND FREQUENCY	380 V 60HZ
6. ROTOR TYPE	SQUIRREL CAGE ROTOR TYPE
7. RATING	15 MIN
8. LOCATION	IN-DOOR , OUTDOOR
9. INSULATION CLASS	B
10. DESIGN TEMPERATURE RISE (BY RESISTANCE)	100℃
11. FULL LOAD SPEED	1140 RPM
12. FULL LOAD CURRENT	1.7 A
13. STARTING CURRENT AT RATED VOLTAGE	9.3 A
14. MINIMUM STARTING VOLTAGE	342 V
15. EFFICIENCY AT 100% RATED LOAD	53 %
16. POWER FACTOR AT 100% RATED LOAD	51 %
17. STARTING TORQUE	249 %
18. TYPE OF ENCLOSURE	전폐형
19. TYPE OF BEARING	PL : 6008DD OPL : 6207ZZ
20. MOUNTING	VERTICAL
21. MAXIMUM AMBIENT TEMPERATURE	40℃
22. BEARING LUBRICATION	GREASE
23. STARTING METHOD	FULL VOLTAGE

SCHEDULE OF TECHNICAL DATA

1. SERVICE	TRAVERSING
2. MANUFACTURE	LK HOIST CO. LTD
3. MOTOR MODEL NO	0.4/0.14 - 4/12 - 38
4. RATED POWER	0.4/0.14 KW × 4/12 P
5. RATED VOLTAGE AND FREQUENCY	380 V 60HZ
6. MOTOR TYPE	SQUIRREL CAGE ROTOR TYPE
7. RATING	15 MIN
8. LOCATION	IN-DOOR , OUTDOOR
9. INSULATION CLASS	B
10. DESIGN TEMPERATURE RISE (BY RESISTANCE)	100℃
11. FULL LOAD SPEED	1710 / 550 RPM
12. FULL LOAD CURRENT	1.8 / 1.1 A
13. STARTING CURRENT AT RATED VOLTAGE	8.96 / 5.47 A
14. MINIMUM STARTING VOLTAGE	343 V
15. EFFICIENCY AT 100% RATED LOAD	59 / 47.3 %
16. POWER FACTOR AT 100% RATED LOAD	67.2 / 42.3 %
17. STARTING TORQUE	232/ 234 %
18. TYPE OF ENCLOSURE	전폐형
19. TYPE OF BEARING	PL : 6008DD OPL : 6207ZZ
20. MOUNTING	VERTICAL
21. MAXIMUM AMBIENT TEMPURE	40℃
22. BEARING LUBRICATION	GREASE
23. STARTING METHOD	FULL VOLTAGE