

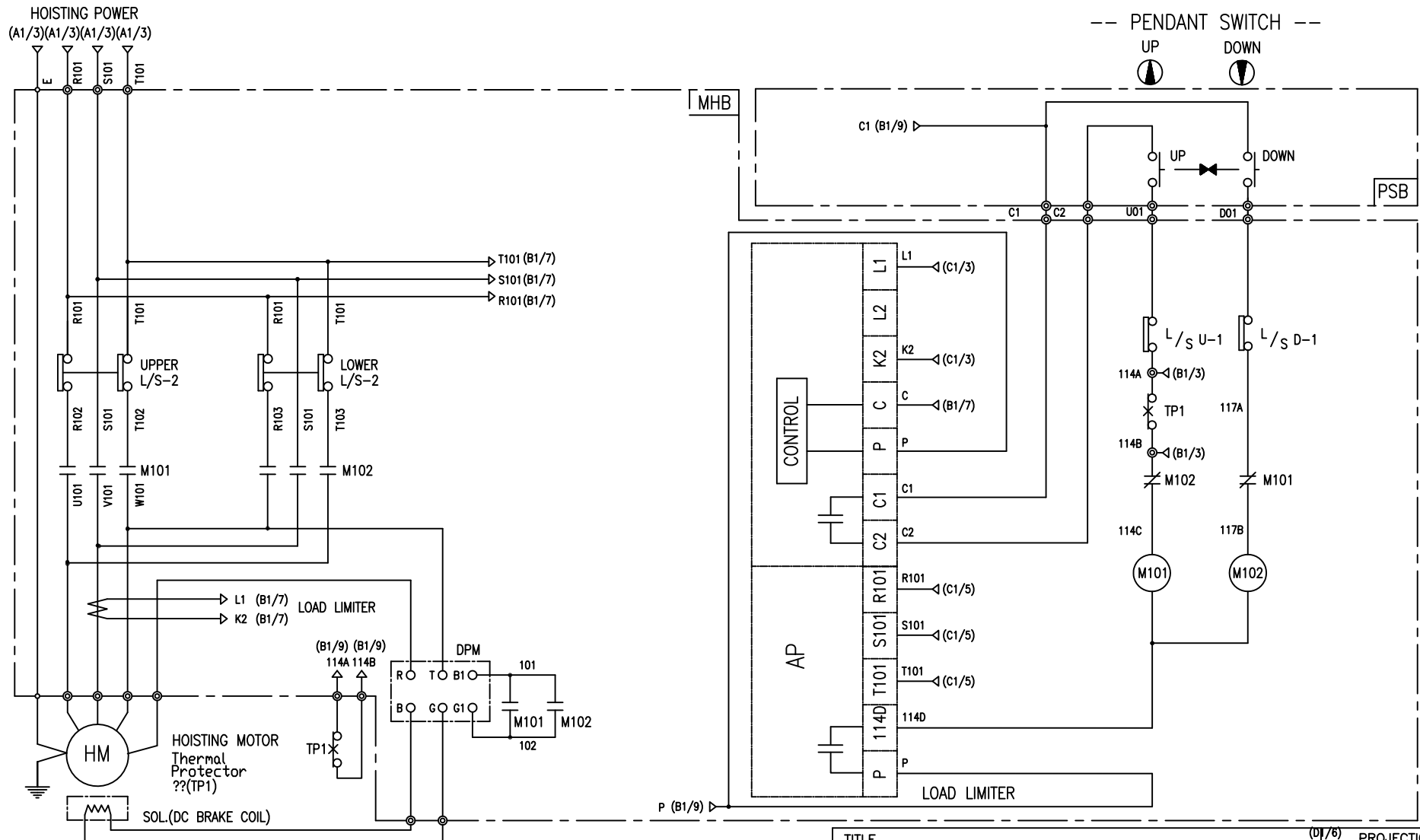

HOIST POWER CIRCUIT

HOIST CONTROL CIRCUIT



-NOTE-  
1. : Mechanical Interlock

TITLE						PROJECTION	
HOIST POWER & CONTROL CIRCUIT DIAGRAM							
WORK NO	WORK NAME					SCALE	Q' TY
603	DA					1/1	1
380V							
DRAWN	CHECKED	REVIEWED	APPROVED	MODEL	DA		
LEE.G.H				CODE NO			
2010.07.30							
L K HOIST CO., LTD.							

SPECIFICATION	MAGNET CONTACT	LOAD LIMITER	SILICON RECTIFIER	Thermal Protector	HOIST MOTOR
SYMBOLS	M101, M102	-	DPM	TP1	HM
DESCRIPTION	DMC-12 GMC-12	LKDL-601	DC99V	17AM032	1.8Kw * 4P
MAKER	DONG-A LS	LK	LK	Texas Instruments	LK

## SCHEDULE OF TECHNICAL DATA

1. SERVICE	HOISTING
2. MANUFACTURE	LK HOIST CO. LTD
3. MOTOR MODEL NO	1.8 - 4 - 38
4. RATED POWER	1.8 KW × 4 P
5. RATED VOLTAGE AND FREQUENCY	380 V      60HZ
6. MOTOR TYPE	SQUIRREL CAGE ROTOR TYPE
7. RATING	30 MIN
8. LOCATION	IN-DOOR , OUTDOOR
9. INSULATION CLASS	B
10. DESIGN TEMPERATURE RISE (BY RESISTANCE)	80℃
11. FULL LOAD SPEED	1740 RPM
12. FULL LOAD CURRENT	5.4 A
13. STARTING CURRENT AT RATED VOLTAGE	26.9 A
14. MINIMUM STARTING VOLTAGE	342 V
15. EFFICIENCY AT 100% RATED LOAD	73.0 %
16. POWER FACTOR AT 100% RATED LOAD	69.4 %
17. STARTING TORQUE	246 %
18. TYPE OF ENCLOSURE	전폐형
19. TYPE OF BEARING	PL : 6008DD    OPL : 6207ZZ
20. MOUNTING	VERTICAL
21. MAXIMUM AMBIENT TEMPURE	40℃
22. BEARING LUBRICATION	GREASE
23. STARTING METHOD	FULL VOLTAGE