

POWER CIRCUIT  
TRAVELLING POWER SUPPLY SYSTEM

ADDRESS NO.  
A1

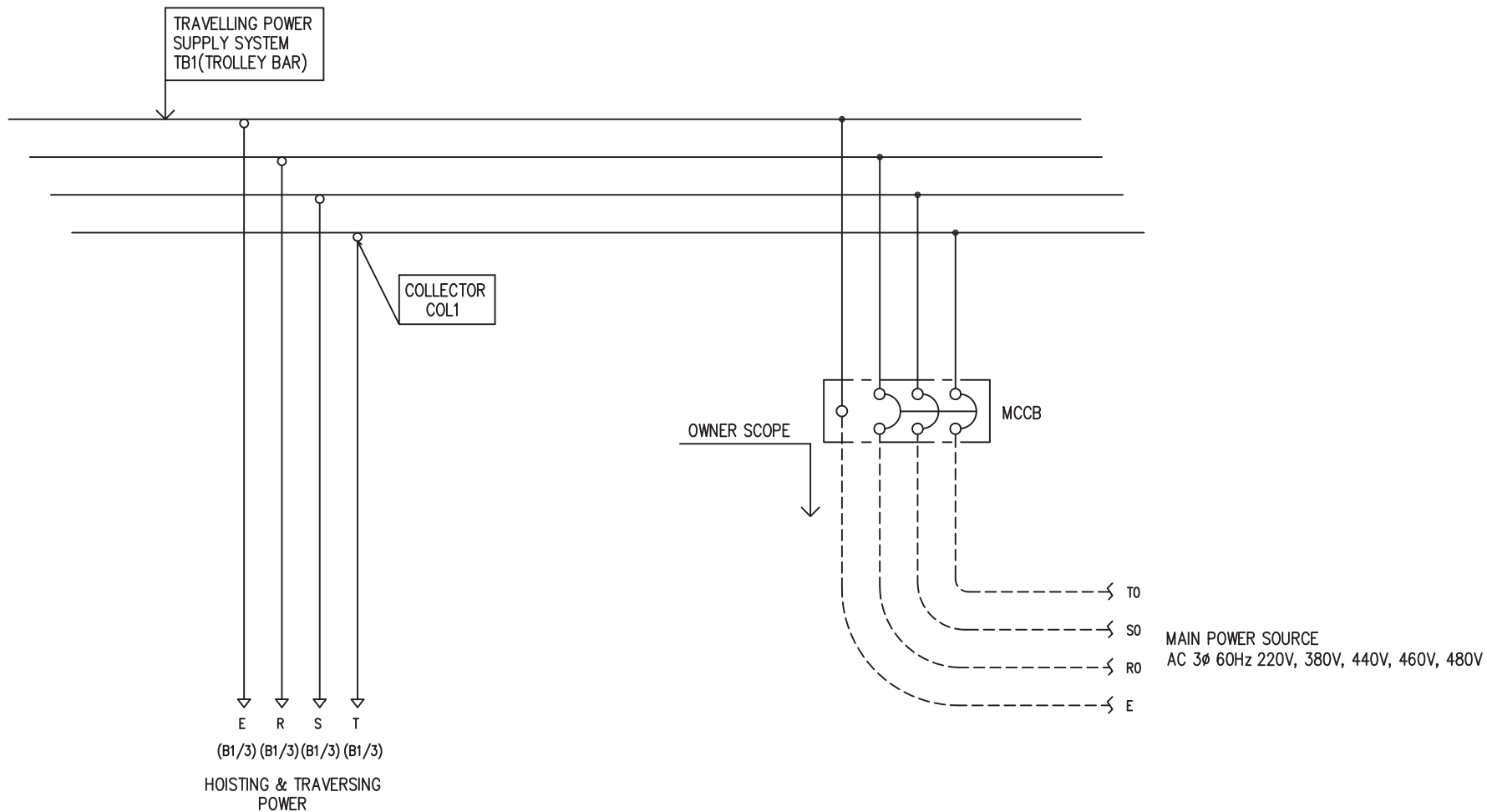

-NOTE-

- 1. - - - - MARKED OWNER SCOPE
- 2. ——— MARKED CRANEMAKER SCOPE

TITLE MAIN POWER CIRCUIT DIAGRAM1				PROJECTION 	
WORK NO 601		WORK NAME LDSM		SCALE 1/1	Q' TY 1
DRAWN LEE G.H. 2010.07.20		CHECKED	REVIEWED	APPROVED	DRAWING NO LDSM
				CODE NO	
L K HOIST CO., LTD.					

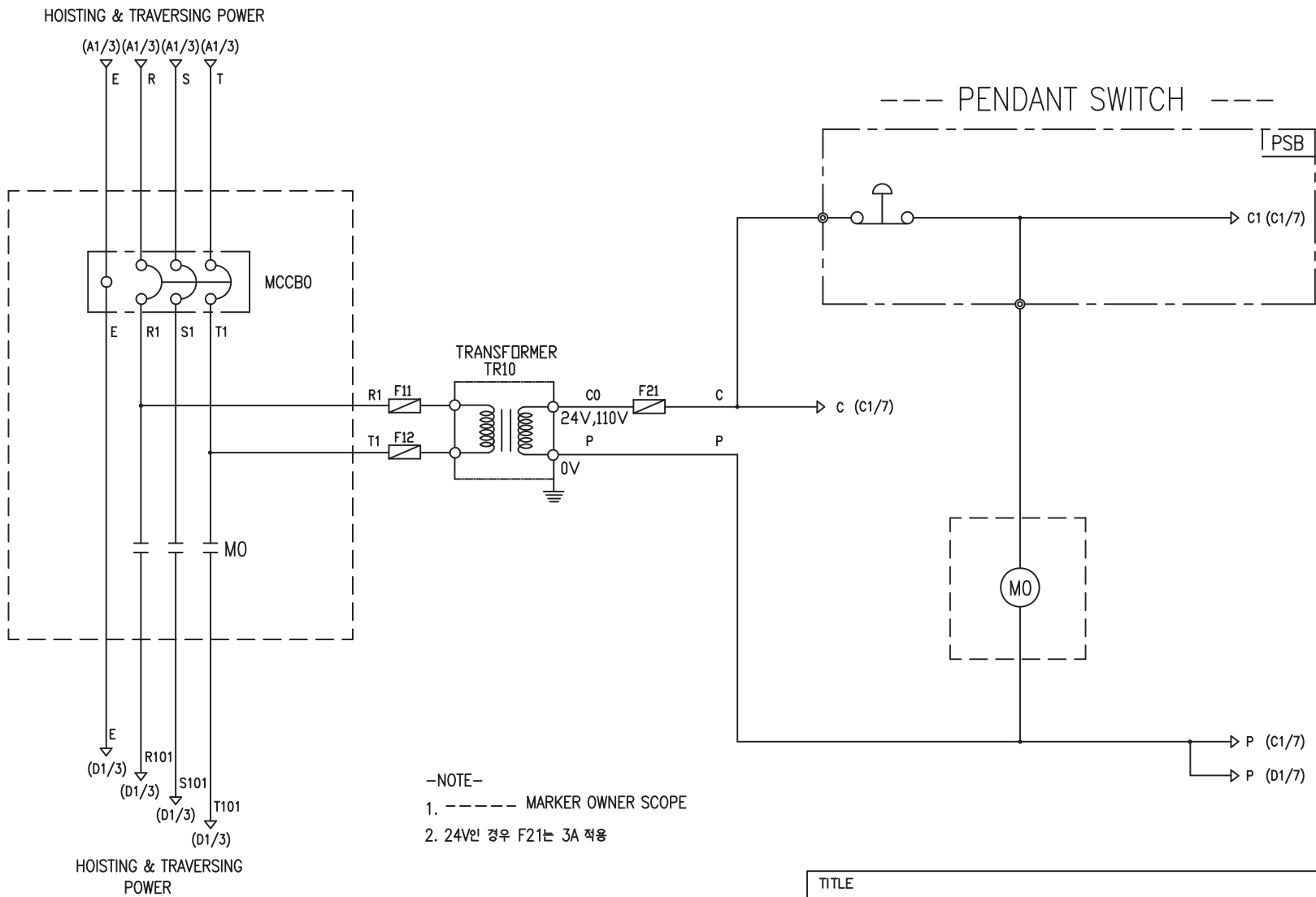

-NOTE-

1. ----- MARKER OWNER SCOPE
2. 24V인 경우 F21는 3A 적용

SPECIFICATION	NO FUSE BREAKER	MAGNET CONTACT	TRANSFORMER	FUSE	
SYMBOLS	MCCB0	MO	TR10	F11, F12, F21	
DESCRIPTION	220V	20A	30VA	1A	
	380V	15A			
	440V	15A			
	460V	15A			
	480V	15A			
MAKER	LS	LS	DONGA	LK	-

TITLE MAIN POWER & CONTROL CIRCUIT DIAGRAM						PROJECTION	
WORK NO 602		WORK NAME LDSM				SCALE 1/1	
DRAWN LEE.G.H		CHECKED		REVIEWED		APPROVED	
2010.07.20		DRAWING NO LDSM		CODE NO		1	
<b>L K HOIST CO., LTD.</b>							

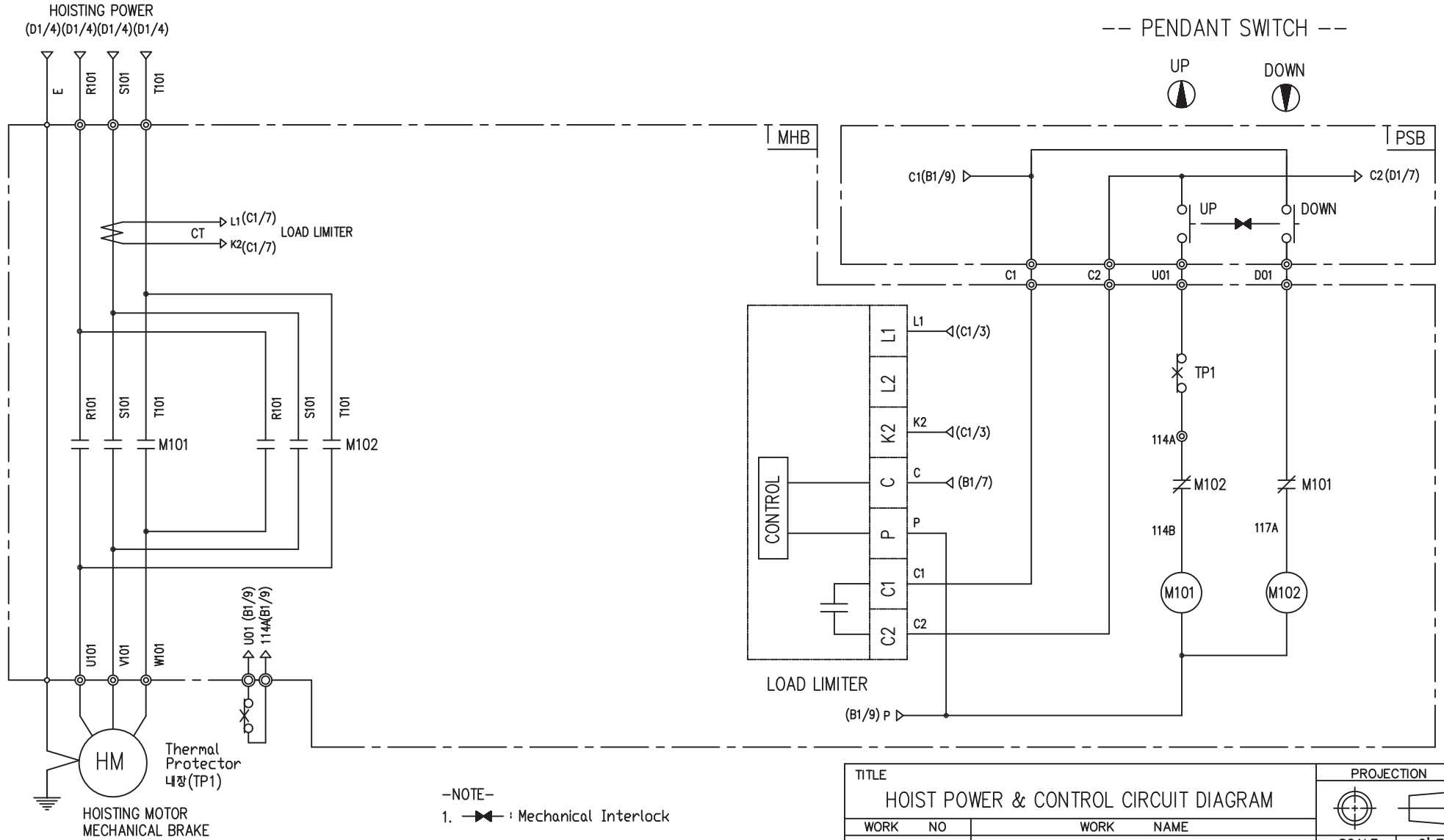

-NOTE-  
1. : Mechanical Interlock

SPECIFICATION	MAGNET CONTACT	LOAD LIMITER	Thermal Protector	HOIST MOTOR
SYMBOLS	M101, M102	-	TP1	HM
DESCRIPTION	GMC12, DMC12	LKDL-501	17AM032	2.0Kw * 4P
MAKER	LS, DONGA	LK	Texas Instruments	LK

TITLE <b>HOIST POWER &amp; CONTROL CIRCUIT DIAGRAM</b>				PROJECTION 	
WORK NO. 603	WORK NAME LDSM			SCALE 1/1	Q' TY 1
220V, 380V, 440V, 460V, 480V					
DRAWN LEE.G.H	CHECKED	REVIEWED	APPROVED	MODEL LDSM	CODE NO
<b>L K HOIST CO., LTD.</b>					

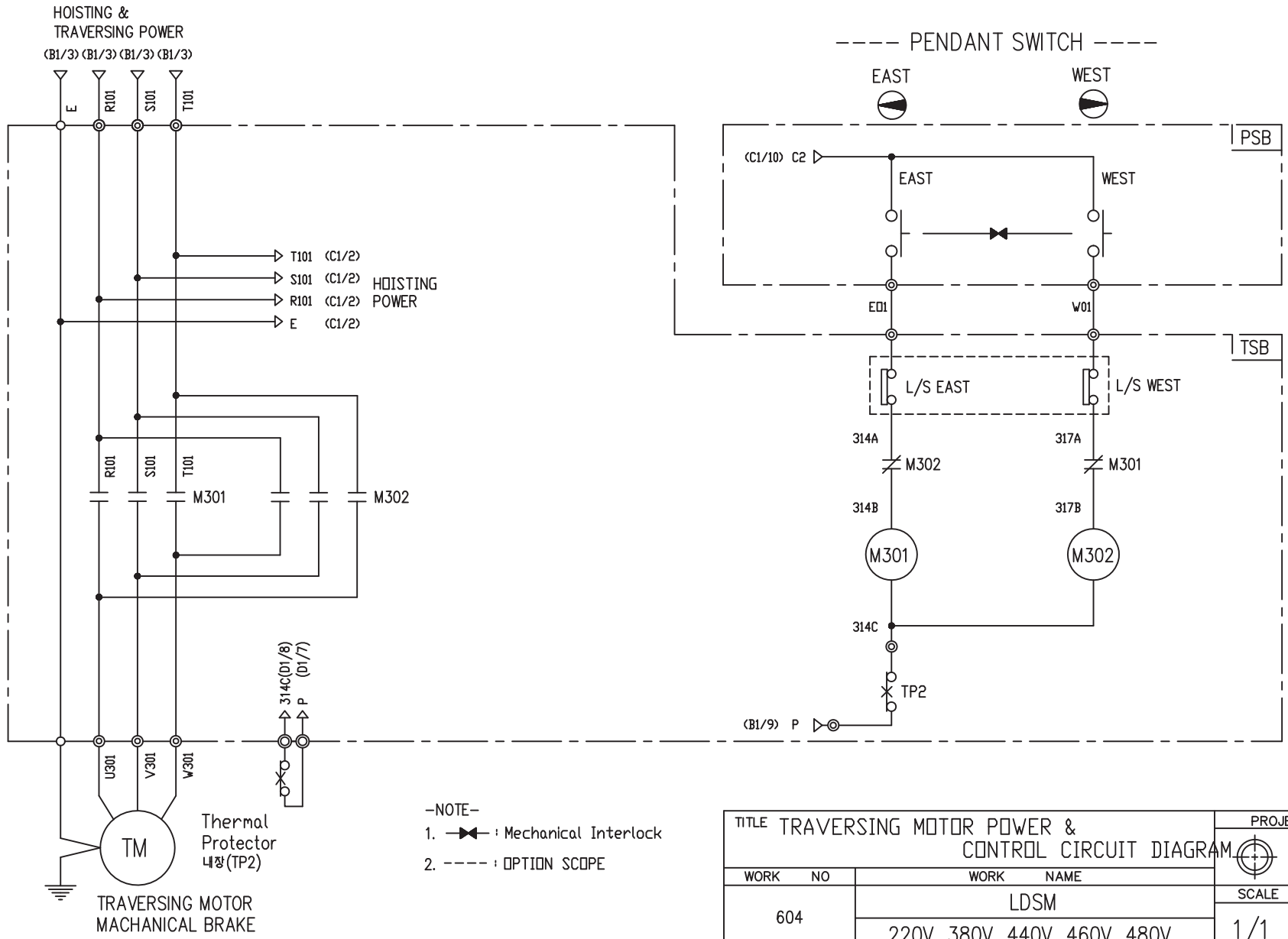

-NOTE-

1. : Mechanical Interlock
2. - - - - : OPTION SCOPE

TITLE TRAVERSING MOTOR POWER & CONTROL CIRCUIT DIAGRAM					PROJECTION	
WORK NO. 604					WORK NAME LDSM	
220V, 380V, 440V, 460V, 480V					SCALE 1/1	Q' TY 1
DRAWN LEE.G.H	CHECKED	REVIEWED	APPROVED	MODEL LDSM		
2010.07.20				CODE NO		
L K HOIST CO., LTD.						

SPECIFICATION	MAGNET CONTACT		Thermal Protector	TRAVERSING MOTOR	
SYMBOLS	M301, M302		TP2	TM	
DESCRIPTION	GMC12	DMC12	17AM032	0.75KW *4P	0.4KW *6P
MAKER	LS	DONGA	Texas Instruments	LK	

TRAVERSING POWER CIRCUIT

TRAVERSING CONTROL CIRCUIT

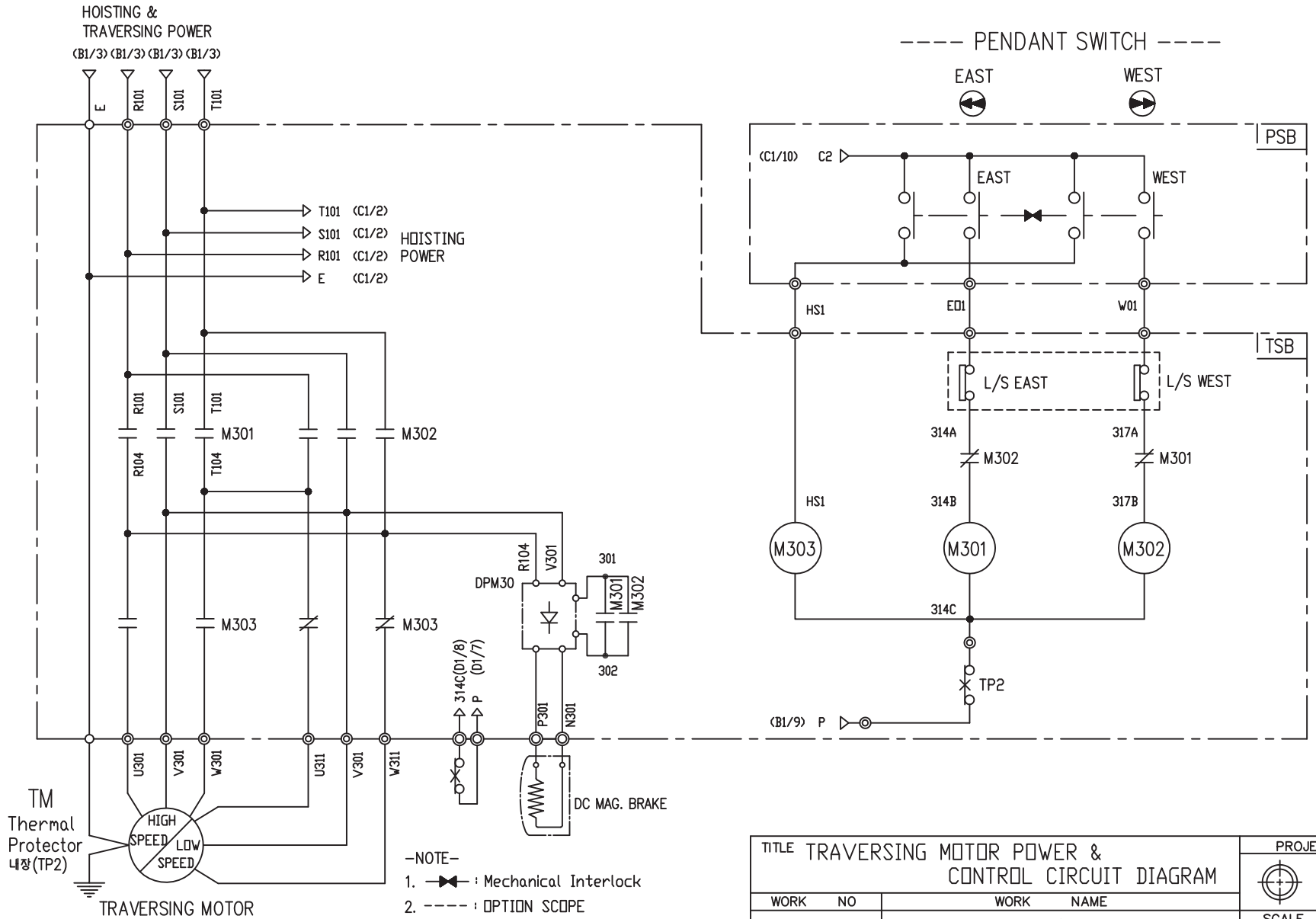

TITLE TRAVERSING MOTOR POWER & CONTROL CIRCUIT DIAGRAM						PROJECTION	
WORK NO 605						WORK NAME LDSM	
220V, 380V, 440V, 460V, 480V						SCALE 1/1	Q' TY 1
DRAWN LEE.G.H	CHECKED	REVIEWED	APPROVED	MODEL	LDSM		
2010.07.20				CODE NO			
<b>LK L K HOIST CO., LTD.</b>							

SPECIFICATION	MAGNET CONTACT		Thermal Protector	SILICON RECTIFIER					TRAVERSING MOTOR
SYMBOLS	M301, M302, M303		TP2	DPM30					TM
DESCRIPTION	GMC12	DMC12	17AM032	AC220V	AC380V	AC440V	AC460V	AC480V	0.75/0.25KW *4/12P
				DC99V	DC171V	DC198V	DC207V	DC216V	
MAKER	LS	DONGA	Texas Instruments	LK					LK

## SCHEDULE OF TECHNICAL DATA

1. SERVICE	HOISTING
2. MANUFACTURE	LK HOIST CO. LTD
3. MOTOR MODEL NO	2.0- 4 - 46
4. RATED POWER	2.0 KW × 4 P
5. RATED VOLTAGE AND FREQUENCY	460 V      60HZ
6. MOTOR TYPE	SQUIRREL CAGE ROTOR TYPE
7. RATING	30 MIN
8. LOCATION	IN-DOOR , OUTDOOR
9. INSULATION CLASS	B
10. DESIGN TEMPERATURE RISE (BY RESISTANCE)	80℃
11. FULL LOAD SPEED	1740 RPM
12. FULL LOAD CURRENT	5.3 A
13. STARTING CURRENT AT RATED VOLTAGE	24.3 A
14. MINIMUM STARTING VOLTAGE	414 V
15. EFFICIENCY AT 100% RATED LOAD	70 %
16. POWER FACTOR AT 100% RATED LOAD	68 %
17. STARTING TORQUE	246 %
18. TYPE OF ENCLOSURE	전폐형
19. TYPE OF BEARING	PL : 6009ZZ    OPL : 6204DD
20. MOUNTING	VERTICAL
21. MAXIMUM AMBIENT TEMPURE	40℃
22. BEARING LUBRICATION	GREASE
23. STARTING METHOD	FULL VOLTAGE

## SCHEDULE OF TECHNICAL DATA

1. SERVICE	TRAVERSING
2. MANUFACTURE	LK HOIST CO. LTD
3. MOTOR MODEL NO	0.75 - 4 - 46
4. RATED POWER	0.75 KW × 4 P
5. RATED VOLTAGE AND FREQUENCY	460 V      60HZ
6. MOTOR TYPE	SQUIRREL CAGE ROTOR TYPE
7. RATING	15 MIN
8. LOCATION	OUTDOOR
9. INSULATION CLASS	B
10. DESIGN TEMPERATURE RISE (BY RESISTANCE)	100℃
11. FULL LOAD SPEED	1710 RPM
12. FULL LOAD CURRENT	2.3 A
13. STARTING CURRENT AT RATED VOLTAGE	12.6 A
14. MINIMUM STARTING VOLTAGE	414 V
15. EFFICIENCY AT 100% RATED LOAD	65 %
16. POWER FACTOR AT 100% RATED LOAD	63 %
17. STARTING TORQUE	250 %
18. TYPE OF ENCLOSURE	전폐형
19. TYPE OF BEARING	PL : 6008DD    OPL : 6207ZZ
20. MOUNTING	VERTICAL
21. MAXIMUM AMBIENT TEMPURE	40℃
22. BEARING LUBRICATION	GREASE
23. STARTING METHOD	FULL VOLTAGE

## SCHEDULE OF TECHNICAL DATA

1. SERVICE	TRAVERSING
2. MANUFACTURE	LK HOIST CO. LTD
3. MOTOR MODEL NO	0.4 - 6 - 46
4. RATED POWER	0.4 KW × 6 P
5. RATED VOLTAGE AND FREQUENCY	460 V      60HZ
6. ROTOR TYPE	SQUIRREL CAGE ROTOR TYPE
7. RATING	15 MIN
8. LOCATION	OUTDOOR
9. INSULATION CLASS	B
10. DESIGN TEMPERATURE RISE (BY RESISTANCE)	100℃
11. FULL LOAD SPEED	1140 RPM
12. FULL LOAD CURRENT	1.53 A
13. STARTING CURRENT AT RATED VOLTAGE	8.4 A
14. MINIMUM STARTING VOLTAGE	414 V
15. EFFICIENCY AT 100% RATED LOAD	65 %
16. POWER FACTOR AT 100% RATED LOAD	63 %
17. STARTING TORQUE	249 %
18. TYPE OF ENCLOSURE	전폐형
19. TYPE OF BEARING	PL : 6008DD    OPL : 6207ZZ
20. MOUNTING	VERTICAL
21. MAXIMUM AMBIENT TEMPERATURE	40℃
22. BEARING LUBRICATION	GREASE
23. STARTING METHOD	FULL VOLTAGE

## SCHEDULE OF TECHNICAL DATA

1. SERVICE	TRAVERSING
2. MANUFACTURE	LK HOIST CO. LTD
3. MOTOR MODEL NO	0.75/0.25 - 4/12 - 46
4. RATED POWER	0.75/0.25 KW × 4/12 P
5. RATED VOLTAGE AND FREQUENCY	460 V      60HZ
6. MOTOR TYPE	SQUIRREL CAGE ROTOR TYPE
7. RATING	15 MIN
8. LOCATION	OUTDOOR
9. INSULATION CLASS	B
10. DESIGN TEMPERATURE RISE (BY RESISTANCE)	100℃
11. FULL LOAD SPEED	1710 / 550 RPM
12. FULL LOAD CURRENT	2.3 / 1.44 A
13. STARTING CURRENT AT RATED VOLTAGE	12.7 / 7.92 A
14. MINIMUM STARTING VOLTAGE	414 V
15. EFFICIENCY AT 100% RATED LOAD	65 / 48 %
16. POWER FACTOR AT 100% RATED LOAD	63 / 45 %
17. STARTING TORQUE	250 / 243 %
18. TYPE OF ENCLOSURE	전폐형
19. TYPE OF BEARING	PL : 6008DD    OPL : 6207ZZ
20. MOUNTING	VERTICAL
21. MAXIMUM AMBIENT TEMPURE	40℃
22. BEARING LUBRICATION	GREASE
23. STARTING METHOD	FULL VOLTAGE