

TRAVELLING POWER
SUPPLY SYSTEM
TB1(Trolley Bar
or Festoon Type)

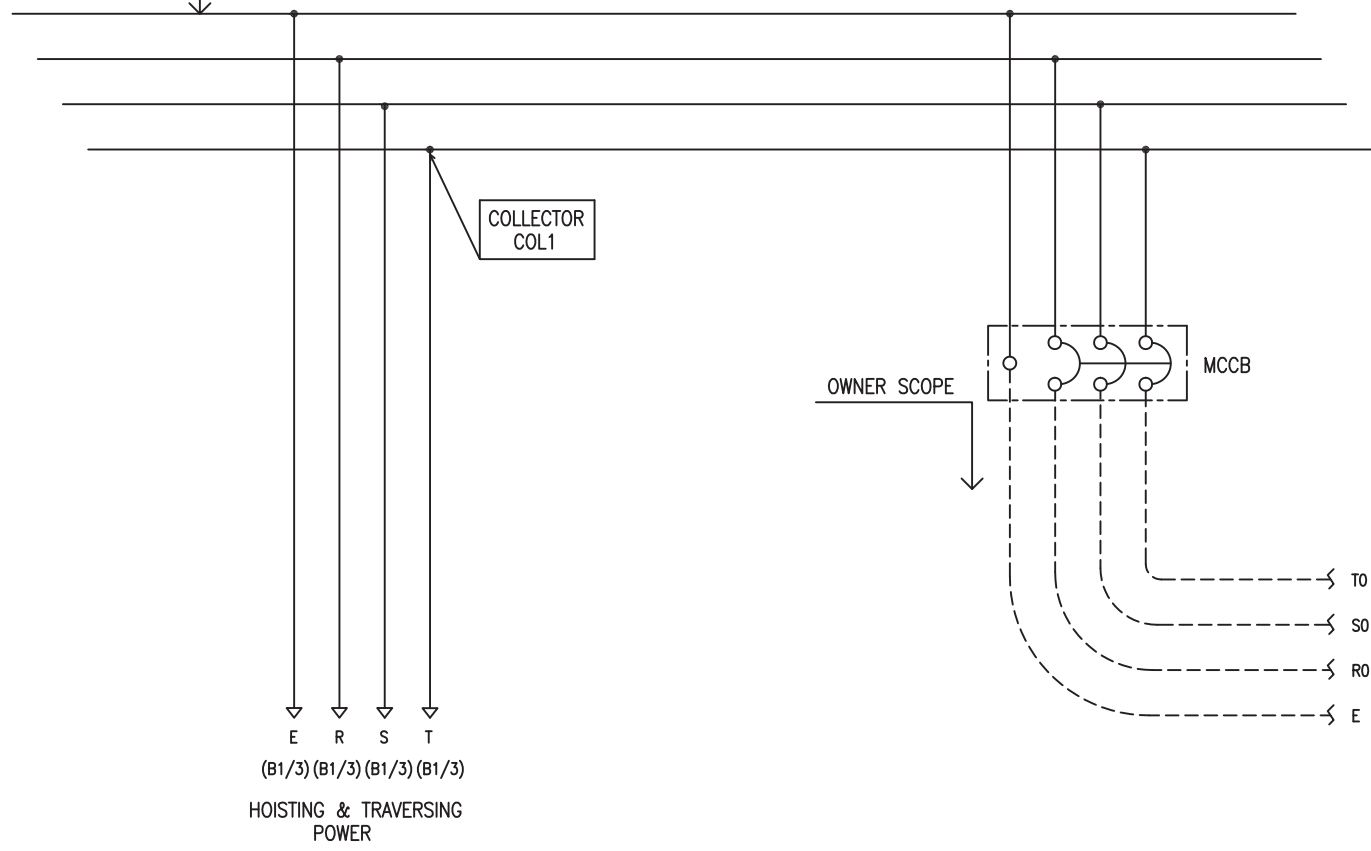

HOISTING & TRAVERSING
POWER

MAIN POWER SOURCE
AC 3Ø 60Hz 220V, 380V, 440V, 460V, 480V

-NOTE-

- 1. - - - - MARKED OWNER SCOPE
- 2. ——— MARKED CRANE MAKER SCOPE

TITLE MAIN POWER CIRCUIT DIAGRAM1						PROJECTION 	
WORK NO 601		WORK NAME DBM				SCALE 1/1	Q' TY 1
DRAWN LEE.G.H 2010.07.30						CHECKED	REVIEWED
APPROVED						MODEL DBM	CODE NO
L K HOIST CO., LTD.							

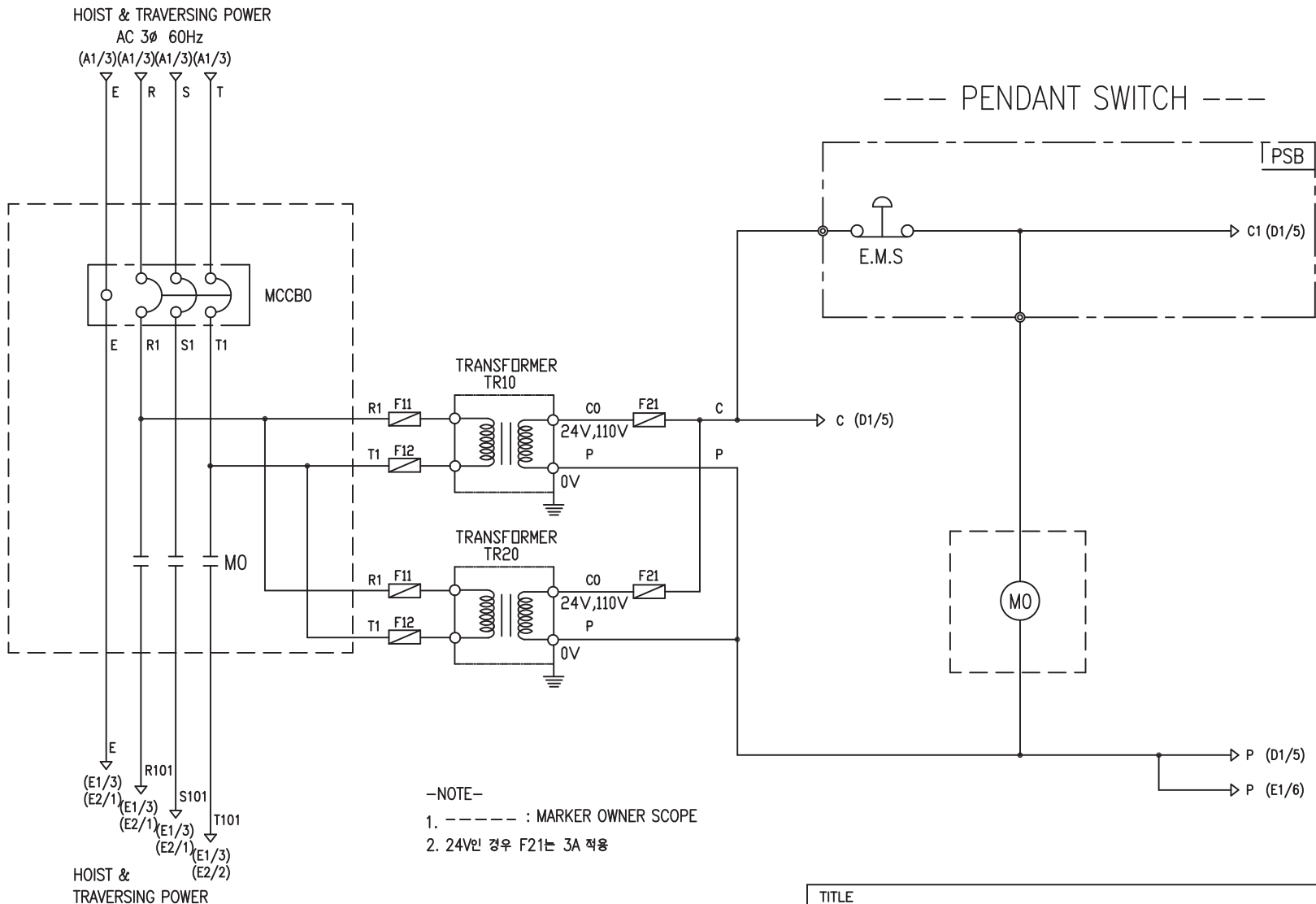

-NOTE-

1. ----- : MARKER OWNER SCOPE
2. 24V인 경우 F21는 3A 적용

SPECIFICATION	NO FUSE BREAKER	MAGNET CONTACT	TRANSFORMER	FUSE		
SYMBOLS	MCCB0	MO	TR10, TR20	F11, F12, F21		
DESCRIPTION	220V	100A	GMC40	DMC40b	60VA	1A
	380V	75A				
	440V	60A				
	460V	60A				
480V	60A					
MAKER	LS	LS	DONGA	LK	-	

TITLE MAIN POWER & CONTROL CIRCUIT DIAGRAM						PROJECTION 	
WORK NO 602		WORK NAME DBM				SCALE 1/1	Q' TY 1
DRAWN LEE.G.H	CHECKED	REVIEWED	APPROVED	MODEL	DBM		
2010.07.30				CODE NO			
L K HOIST CO., LTD.							

HOIST POWER CIRCUIT

HOISTING POWER

(E1/4)(E1/4)(E1/4)(E1/4)
(E2/3)(E2/3)(E2/3)(E2/3)

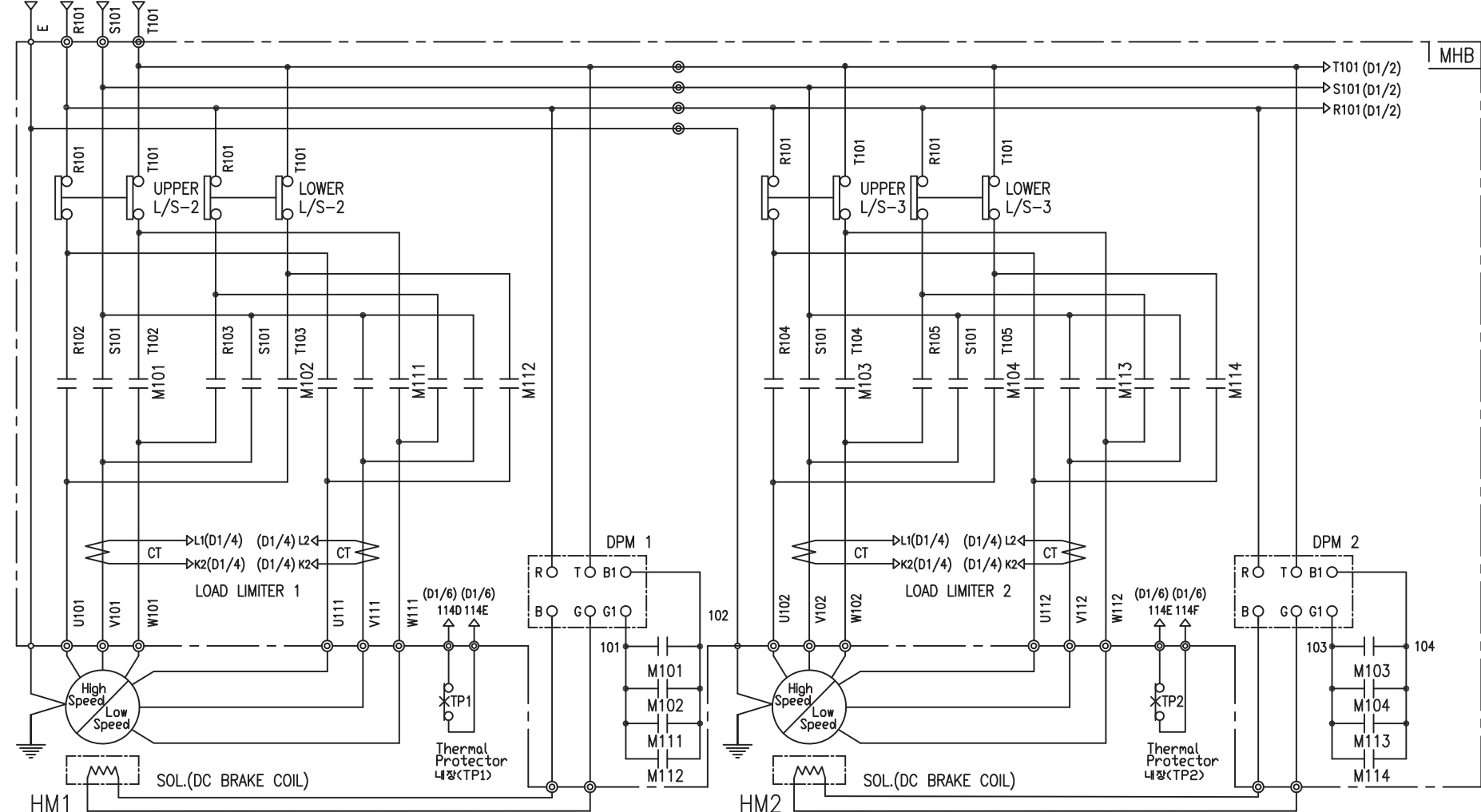

MHB

SPECIFICATION	MAGNET CONTACT		SILICON RECTIFIER				Thermal Protector	HOIST MOTOR
SYMBOLS	M101, M102, M103, M104 M111, M112, M113, M114		DPM1, DPM2				TP1, TP2	HM1, HM2
DESCRIPTION	GMC22	DMC22b	AC380V DC171V	AC440V DC198V	AC460V DC207V	AC480V DC216V	17AM032	4.4Kw * 2P/2.2Kw * 6P (2SET)
MAKER	LS	DONGA	LK				Texas Instruments	LK

TITLE						PROJECTION	
HOIST POWER & CONTROL CIRCUIT DIAGRAM							
WORK NO		WORK NAME				SCALE	Q' TY
604		DBM				1/1	1
380V, 440V, 460V, 480V		DRAWN		CHECKED	REVIEWED	APPROVED	MODEL
2004.08.30		LEE.G.H					DBM
						CODE NO	
L K HOIST CO., LTD.							

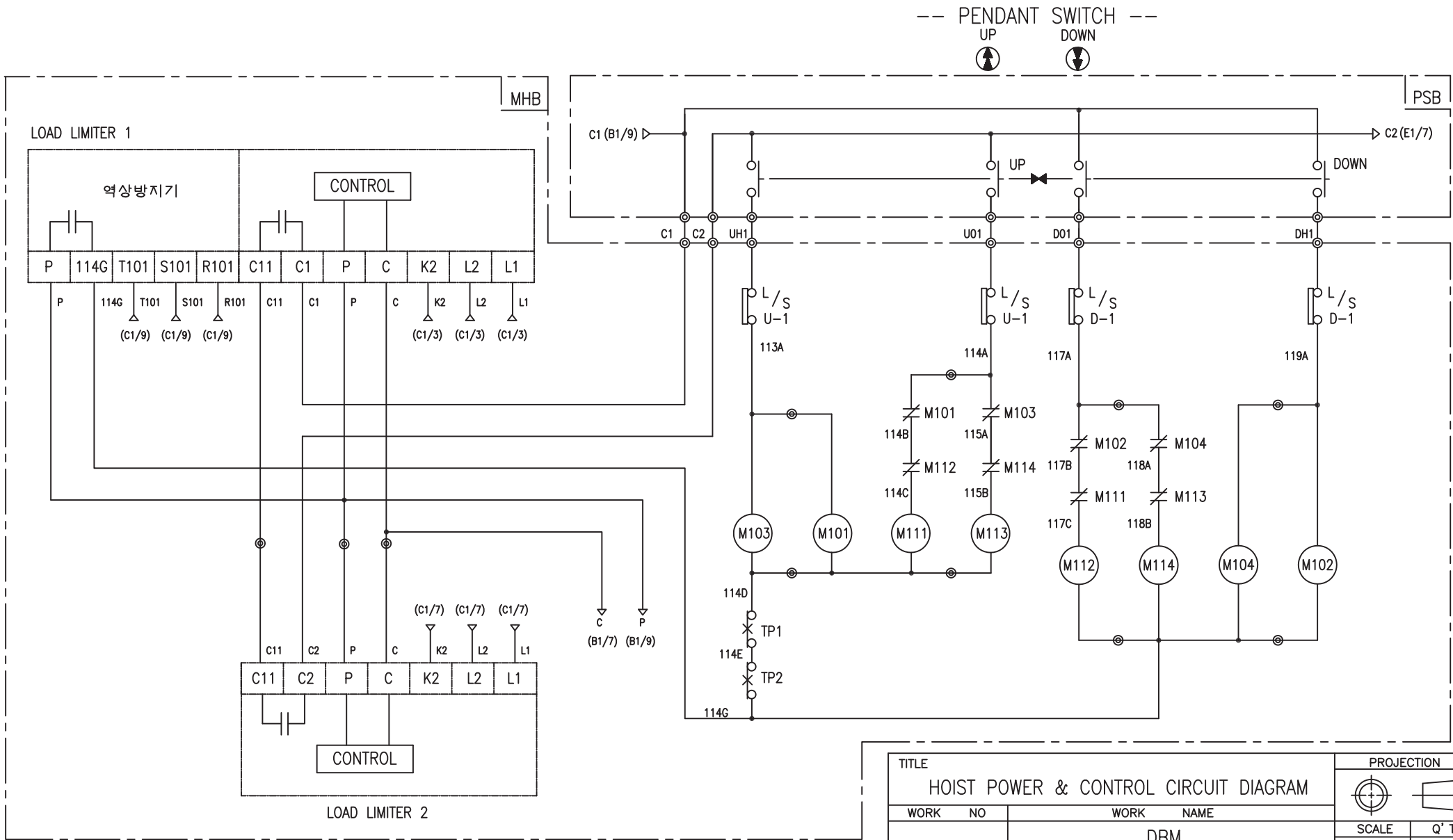

-NOTE-
 1. : Mechanical Interlock

SPECIFICATION	LOAD LIMITER 1	LOAD LIMITER 2
SYMBOLS	-	-
DESCRIPTION	LKDL-601	LKDL-501
MAKER	LK	

TITLE				PROJECTION	
HOIST POWER & CONTROL CIRCUIT DIAGRAM					
WORK NO.	WORK NAME			SCALE	Q' TY
605	DBM			1/1	1
220V, 380V, 440V, 460V, 480V					
DRAWN	CHECKED	REVIEWED	APPROVED	MODEL	DBM10W
LEE.G.H				CODE NO	
2010.07.30					

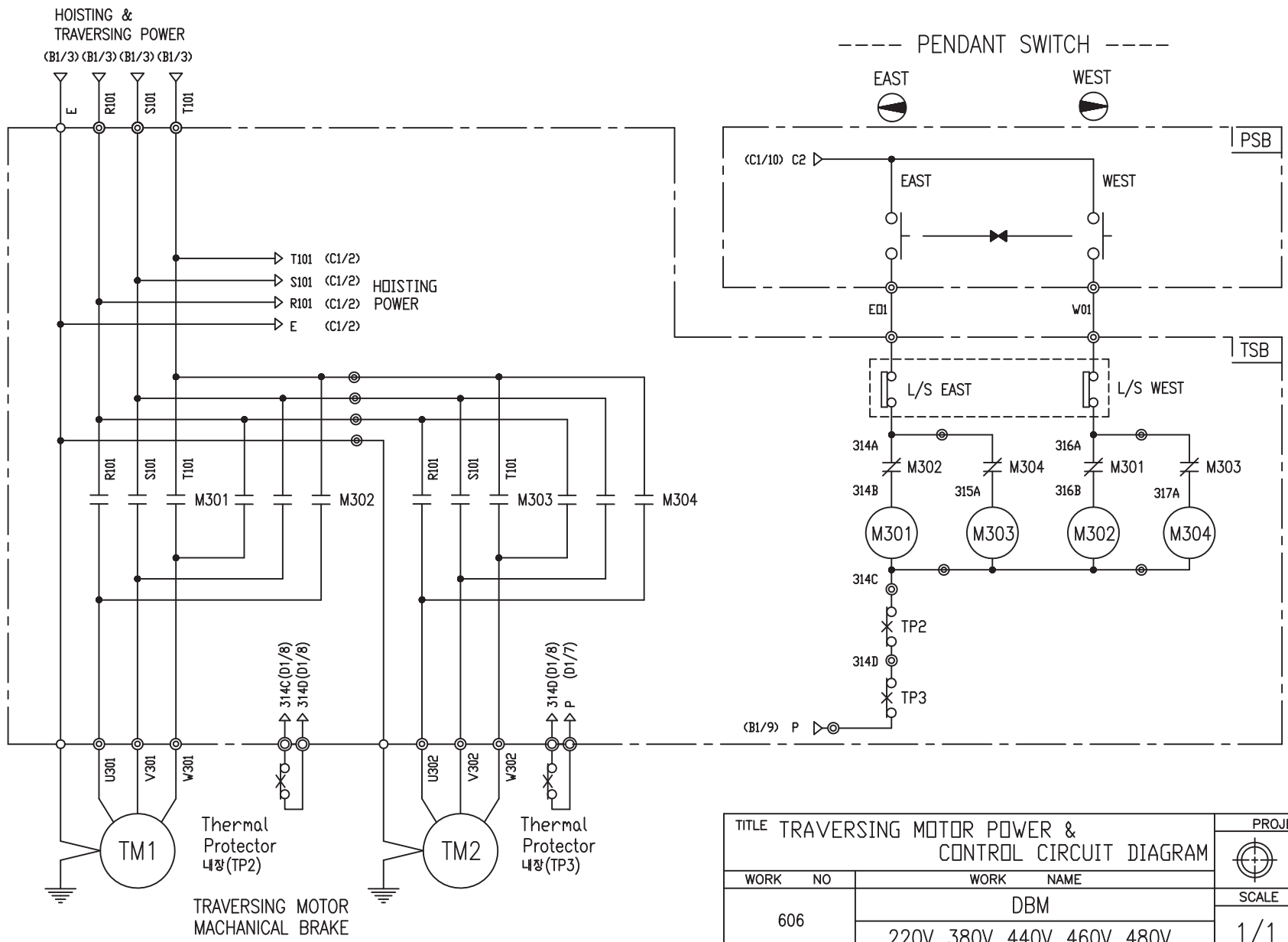

SPECIFICATION	MAGNET CONTACT	Thermal Protector	TRAVERSING MOTOR
SYMBOLS	M301,M302,M303,M304	TP2, TP3	TM1, TM2
DESCRIPTION	GMC12 DMC12	17AM032	0.75KW *4P 0.4KW *6P
MAKER	LS DONGA	Texas Instruments	LK

-NOTE-
 1. —|— : Mechanical Interlock
 2. - - - - : OPTION SCOPE

TITLE TRAVERSING MOTOR POWER & CONTROL CIRCUIT DIAGRAM						PROJECTION	
WORK NO		WORK NAME					
606		DBM				SCALE	Q' TY
		220V, 380V, 440V, 460V, 480V				1/1	1
DRAWN	CHECKED	REVIEWED	APPROVED	MODEL	DBM		
LEE.G.H				CODE NO			
2010.07.30							
L K HOIST CO., LTD.							

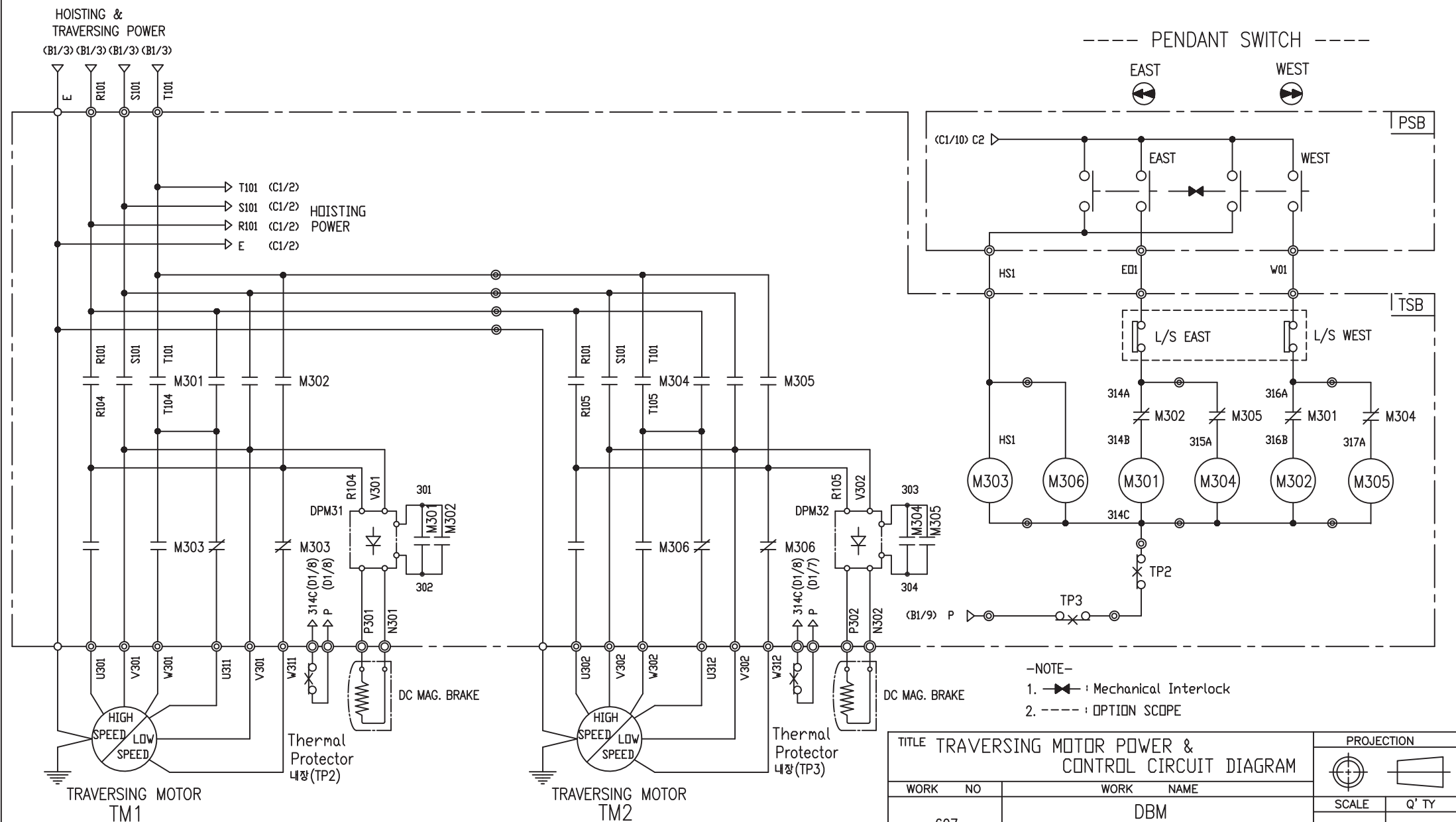

-NOTE-

1. : Mechanical Interlock
2. : OPTION SCOPE

SPECIFICATION	MAGNET CONTACT	Thermal Protector	SILICON RECTIFIER					TRAVERSING MOTOR
SYMBOLS	M301, M302, M303 M304, M305, M306	TP2, TP3	DPM31, DPM32					TM1, TM2
DESCRIPTION	GMC12 DMC12	17AM032	AC220V	AC380V	AC440V	AC460V	AC480V	0.75/0.25KW *4/12P
			DC99V	DC171V	DC198V	DC207V	DC216V	
MAKER	LS DONGA	Texas Instruments	LK					LK

TITLE TRAVERSING MOTOR POWER & CONTROL CIRCUIT DIAGRAM						PROJECTION	
WORK NO		WORK NAME					
607		DBM				SCALE	Q' TY
220V, 380V, 440V, 460V, 480V		1/1		1			
DRAWN	CHECKED	REVIEWED	APPROVED	MODEL	DBM		
LEE.G.H				CODE NO			
2010.07.30							

SCHEDULE OF TECHNICAL DATA

1. SERVICE	HOISTING
2. MANUFACTURE	LK HOIST CO. LTD
3. MOTOR MODEL NO	4.4/2.2 - 2/6 - 46
4. RATED POWER	4.4/2.2 KW × 2/6 P
5. RATED VOLTAGE AND FREQUENCY	460 V 60HZ
6. MOTOR TYPE	SQUIRREL CAGE ROTOR TYPE
7. RATING	30 MIN
8. LOCATION	OUTDOOR
9. INSULATION CLASS	B
10. DESIGN TEMPERATURE RISE (BY RESISTANCE)	80℃
11. FULL LOAD SPEED	3440/1140 RPM
12. FULL LOAD CURRENT	11/5.3 A
13. STARTING CURRENT AT RATED VOLTAGE	54/28 A
14. MINIMUM STARTING VOLTAGE	414 V
15. EFFICIENCY AT 100% RATED LOAD	73/73 %
16. POWER FACTOR AT 100% RATED LOAD	71/71 %
17. STARTING TORQUE	243 %
18. TYPE OF ENCLOSURE	전폐형
19. TYPE OF BEARING	PL : 6205DD OPL : 6008ZZ
20. MOUNTING	VERTICAL
21. MAXIMUM AMBIENT TEMPURE	40℃
22. BEARING LUBRICATION	GREASE
23. STARTING METHOD	FULL VOLTAGE

SCHEDULE OF TECHNICAL DATA

1. SERVICE	TRAVERSING
2. MANUFACTURE	LK HOIST CO. LTD
3. MOTOR MODEL NO	0.75 - 4 - 46
4. RATED POWER	0.75 KW × 4 P
5. RATED VOLTAGE AND FREQUENCY	460 V 60HZ
6. MOTOR TYPE	SQUIRREL CAGE ROTOR TYPE
7. RATING	15 MIN
8. LOCATION	OUTDOOR
9. INSULATION CLASS	B
10. DESIGN TEMPERATURE RISE (BY RESISTANCE)	100℃
11. FULL LOAD SPEED	1670 RPM
12. FULL LOAD CURRENT	2.3 A
13. STARTING CURRENT AT RATED VOLTAGE	12.6 A
14. MINIMUM STARTING VOLTAGE	414 V
15. EFFICIENCY AT 100% RATED LOAD	65 %
16. POWER FACTOR AT 100% RATED LOAD	63 %
17. STARTING TORQUE	250 %
18. TYPE OF ENCLOSURE	전폐형
19. TYPE OF BEARING	PL : 6008DD OPL : 6207ZZ
20. MOUNTING	VERTICAL
21. MAXIMUM AMBIENT TEMPURE	40℃
22. BEARING LUBRICATION	GREASE
23. STARTING METHOD	FULL VOLTAGE

SCHEDULE OF TECHNICAL DATA

1. SERVICE	TRAVERSING
2. MANUFACTURE	LK HOIST CO. LTD
3. MOTOR MODEL NO	0.4 - 6 - 46
4. RATED POWER	0.4 KW × 6 P
5. RATED VOLTAGE AND FREQUENCY	460 V 60HZ
6. ROTOR TYPE	SQUIRREL CAGE ROTOR TYPE
7. RATING	15 MIN
8. LOCATION	OUTDOOR
9. INSULATION CLASS	B
10. DESIGN TEMPERATURE RISE (BY RESISTANCE)	100℃
11. FULL LOAD SPEED	1140 RPM
12. FULL LOAD CURRENT	1.53 A
13. STARTING CURRENT AT RATED VOLTAGE	8.4 A
14. MINIMUM STARTING VOLTAGE	414 V
15. EFFICIENCY AT 100% RATED LOAD	65 %
16. POWER FACTOR AT 100% RATED LOAD	63 %
17. STARTING TORQUE	249 %
18. TYPE OF ENCLOSURE	전폐형
19. TYPE OF BEARING	PL : 6008DD OPL : 6207ZZ
20. MOUNTING	VERTICAL
21. MAXIMUM AMBIENT TEMPERATURE	40℃
22. BEARING LUBRICATION	GREASE
23. STARTING METHOD	FULL VOLTAGE

SCHEDULE OF TECHNICAL DATA

1. SERVICE	TRAVERSING
2. MANUFACTURE	LK HOIST CO. LTD
3. MOTOR MODEL NO	0.75/0.25 - 4/12 - 46
4. RATED POWER	0.75/0.25 KW × 4/12 P
5. RATED VOLTAGE AND FREQUENCY	460 V 60HZ
6. MOTOR TYPE	SQUIRREL CAGE ROTOR TYPE
7. RATING	15 MIN
8. LOCATION	OUTDOOR
9. INSULATION CLASS	B
10. DESIGN TEMPERATURE RISE (BY RESISTANCE)	100℃
11. FULL LOAD SPEED	1670 / 550 RPM
12. FULL LOAD CURRENT	2.3 / 1.44 A
13. STARTING CURRENT AT RATED VOLTAGE	12.7 / 7.92 A
14. MINIMUM STARTING VOLTAGE	414 V
15. EFFICIENCY AT 100% RATED LOAD	65 / 48 %
16. POWER FACTOR AT 100% RATED LOAD	63 / 45 %
17. STARTING TORQUE	250 / 243 %
18. TYPE OF ENCLOSURE	전폐형
19. TYPE OF BEARING	PL : 6008DD OPL : 6207ZZ
20. MOUNTING	VERTICAL
21. MAXIMUM AMBIENT TEMPURE	40℃
22. BEARING LUBRICATION	GREASE
23. STARTING METHOD	FULL VOLTAGE