

POWER CIRCUIT
TRAVELLING POWER SUPPLY SYSTEM

ADDRESS NO.
A1

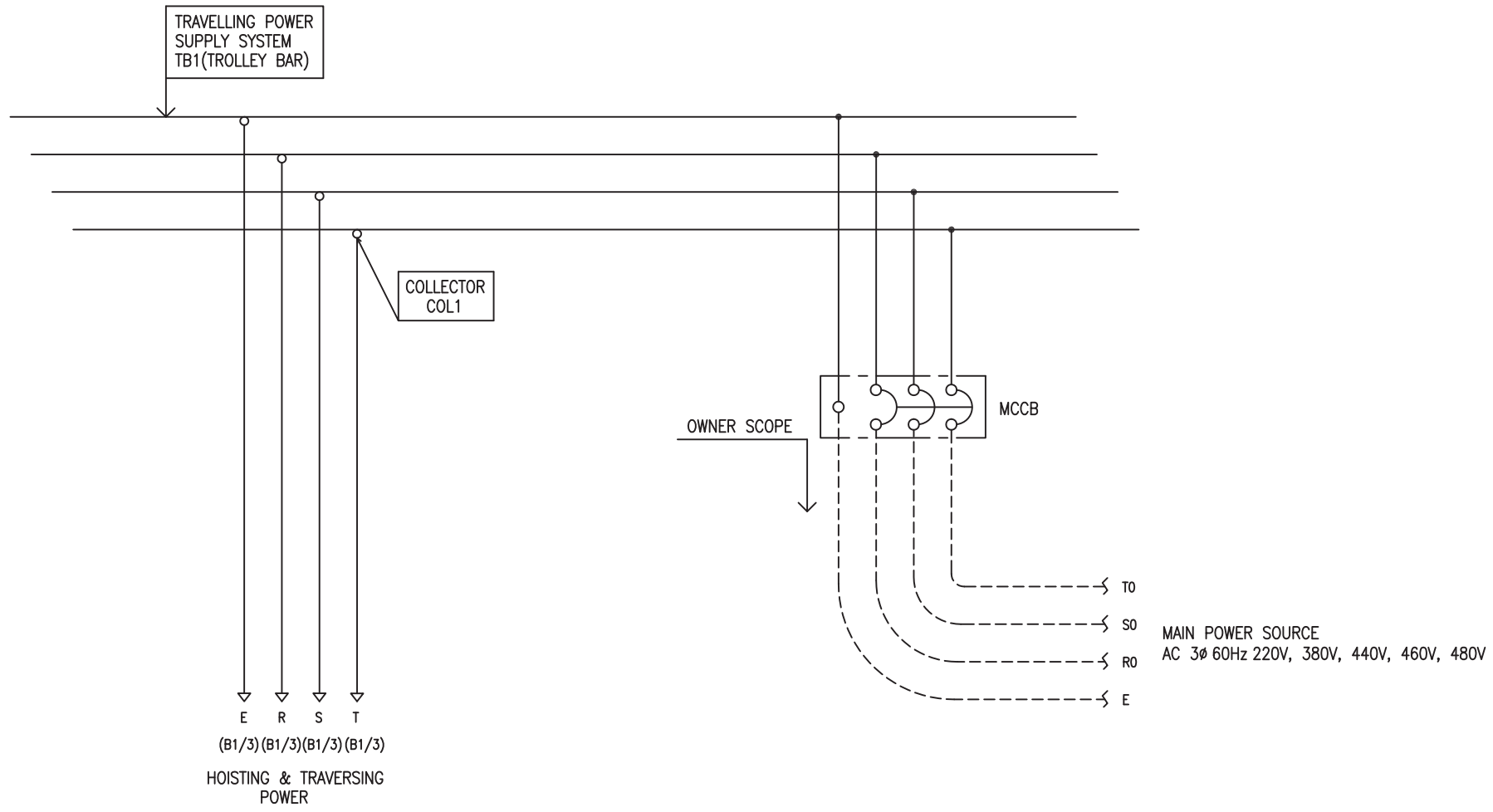

- NOTE-
1. - - - - MARKED OWNER SCOPE
 2. ——— MARKED CRANE MAKER SCOPE

TITLE MAIN POWER CIRCUIT DIAGRAM1				PROJECTION 	
WORK NO 601	WORK NAME DHDAM			SCALE 1/1	Q' TY 1
DRAWN LEE G.H. 2010.07.30	CHECKED	REVIEWED	APPROVED	DRAWING NO DHDAM	CODE NO
L K HOIST CO., LTD.					



-NOTE-

1. ----- MARKER OWNER SCOPE
2. 24V인 경우 F21는 3A 적용

SPECIFICATION	NO FUSE BREAKER	MAGNET CONTACT	TRANSFORMER	FUZE
SYMBOLS	MCCB0	MO	TR10	F11, F12, F21
DESCRIPTION	220V	30A	30VA	1A
	380V	15A		
	440V	15A		
	460V	15A		
	480V	15A		
MAKER	LS	LS	DONGA	LK

TITLE MAIN POWER & CONTROL CIRCUIT DIAGRAM						PROJECTION	
WORK NO 602		WORK NAME DHDAM				SCALE 1/1	
DRAWN LEE.G.H		CHECKED		REVIEWED		APPROVED	
2010.07.30		MODEL DHDAM		CODE NO		1	
L K HOIST CO., LTD.							

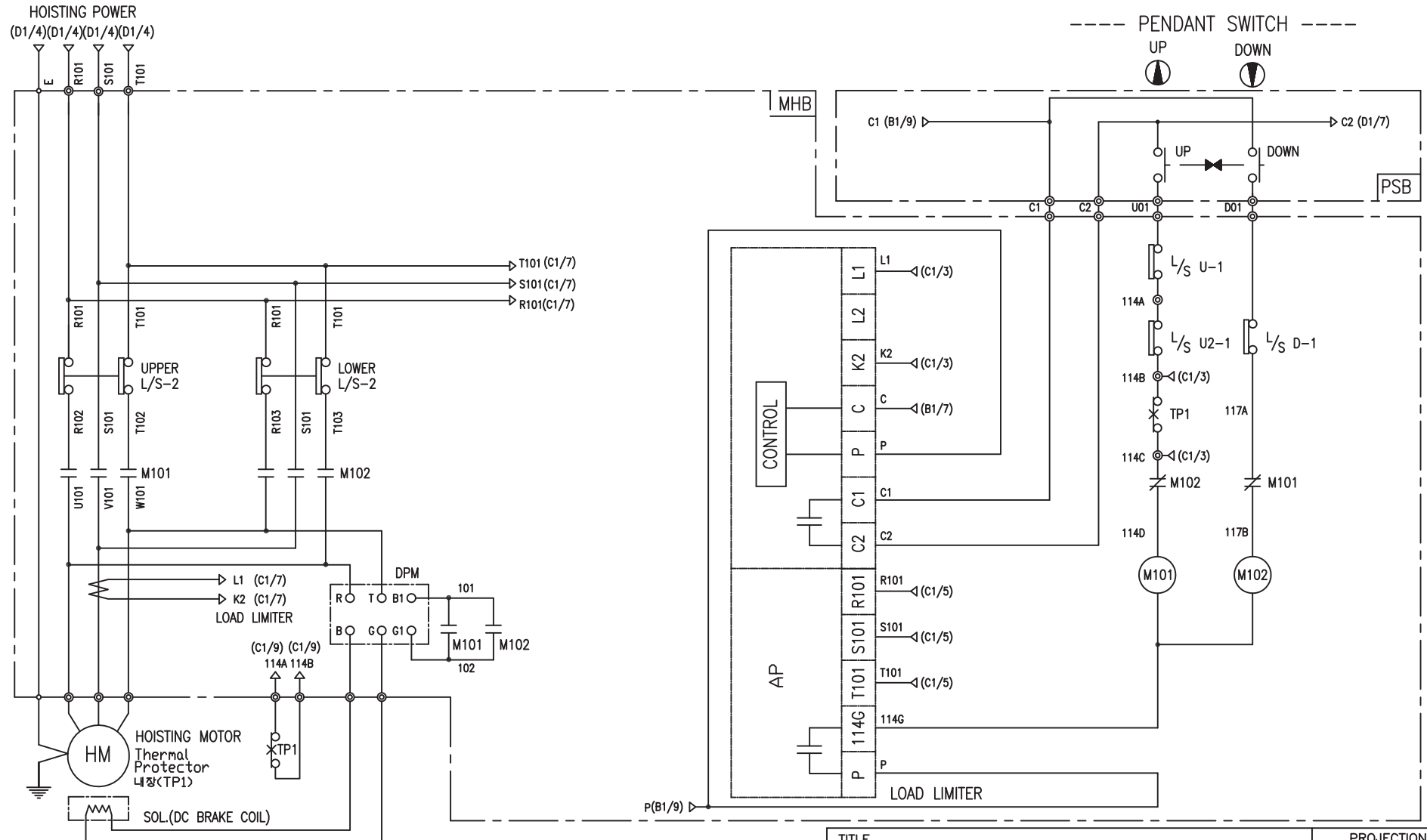

-NOTE-
 1. : Mechanical Interlock

SPECIFICATION	MAGNET CONTACT	LOAD LIMITER	SILICON RECTIFIER				Thermal Protector	HOIST MOTOR	
SYMBOLS	M101, M102	-	DPM				TP1	HM	
DESCRIPTION	DMC-12	GMC-12	LKDL-601	AC220V	AC440V	AC460V	AC480V	17AM032	1.8Kw * 4P
				DC99V	DC198V	DC207V	DC216V		
MAKER	DONG-A	LS	LK	LK			Texas Instruments	LK	

TITLE HOIST POWER & CONTROL CIRCUIT DIAGRAM						PROJECTION 	
WORK NO 603		WORK NAME DHDAM				SCALE 1/1	Q' TY 1
DRAWN LEE.G.H		CHECKED	REVIEWED	APPROVED	MODEL DHDAM	CODE NO	
2010.07.30							
L K HOIST CO., LTD.							

TRAVERSING POWER CIRCUIT

TRAVERSING CONTROL CIRCUIT

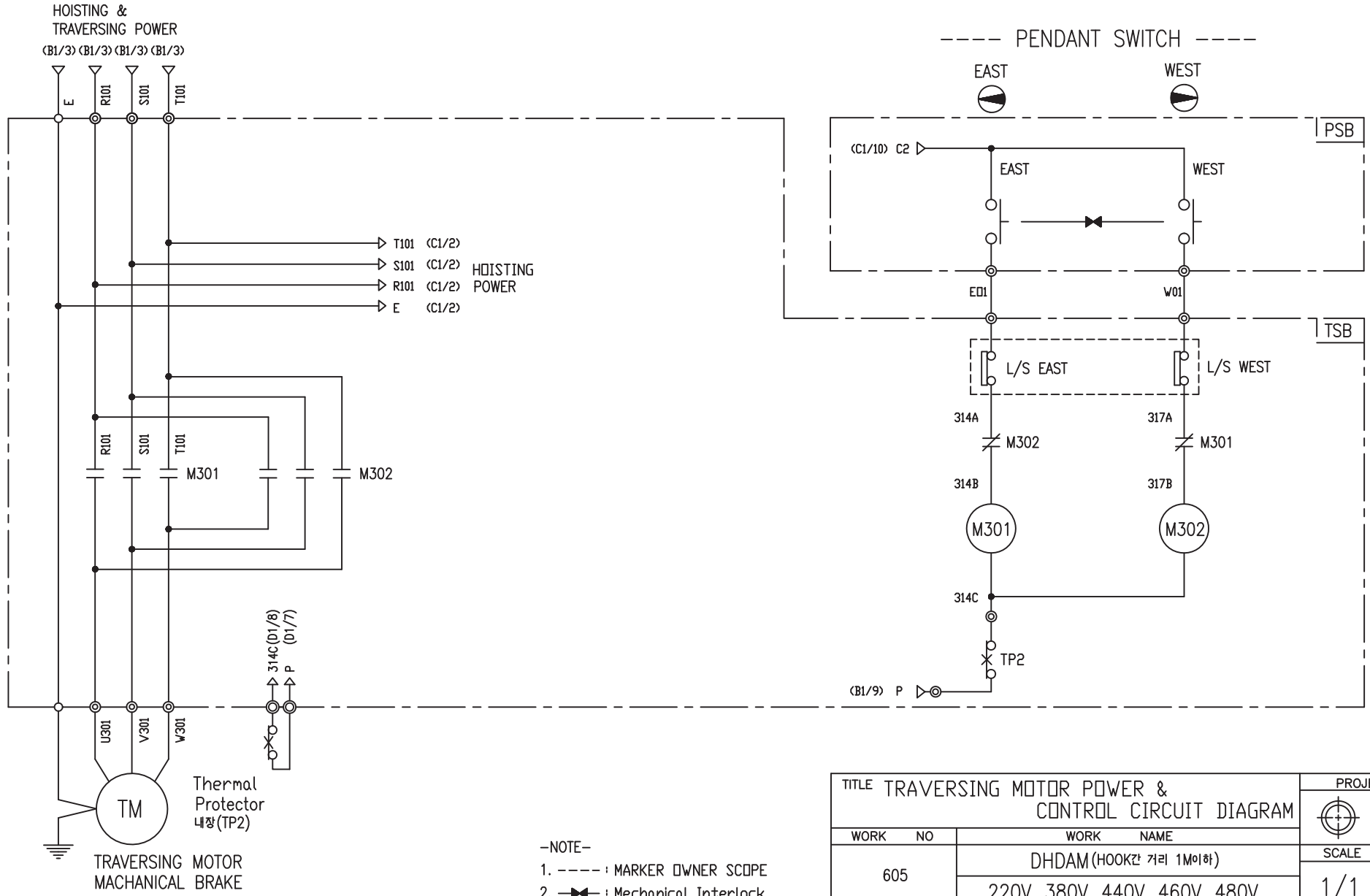

-NOTE-
 1. ----- : MARKER OWNER SCOPE
 2. —|—|— : Mechanical Interlock

TITLE TRAVERSING MOTOR POWER & CONTROL CIRCUIT DIAGRAM						PROJECTION	
WORK NO 605						WORK NAME DHDAM(HOOK장 거리 1M이하)	
220V, 380V, 440V, 460V, 480V						SCALE 1/1	Q' TY 1
DRAWN LEE.G.H	CHECKED	REVIEWED	APPROVED	MODEL	DHDAM		
2010.07.30				CODE NO			
LK L K HOIST CO., LTD.							

SPECIFICATION	MAGNET CONTACT	Thermal Protector	TRAVERSING MOTOR	
SYMBOLS	M301, M302	TP2	TM	
DESCRIPTION	GMC12 DMC12	17AM032	0.4KW *4P	0.3KW *6P
MAKER	LS DONGA	Texas Instruments	LK	

TRAVERSING POWER CIRCUIT

TRAVERSING CONTROL CIRCUIT

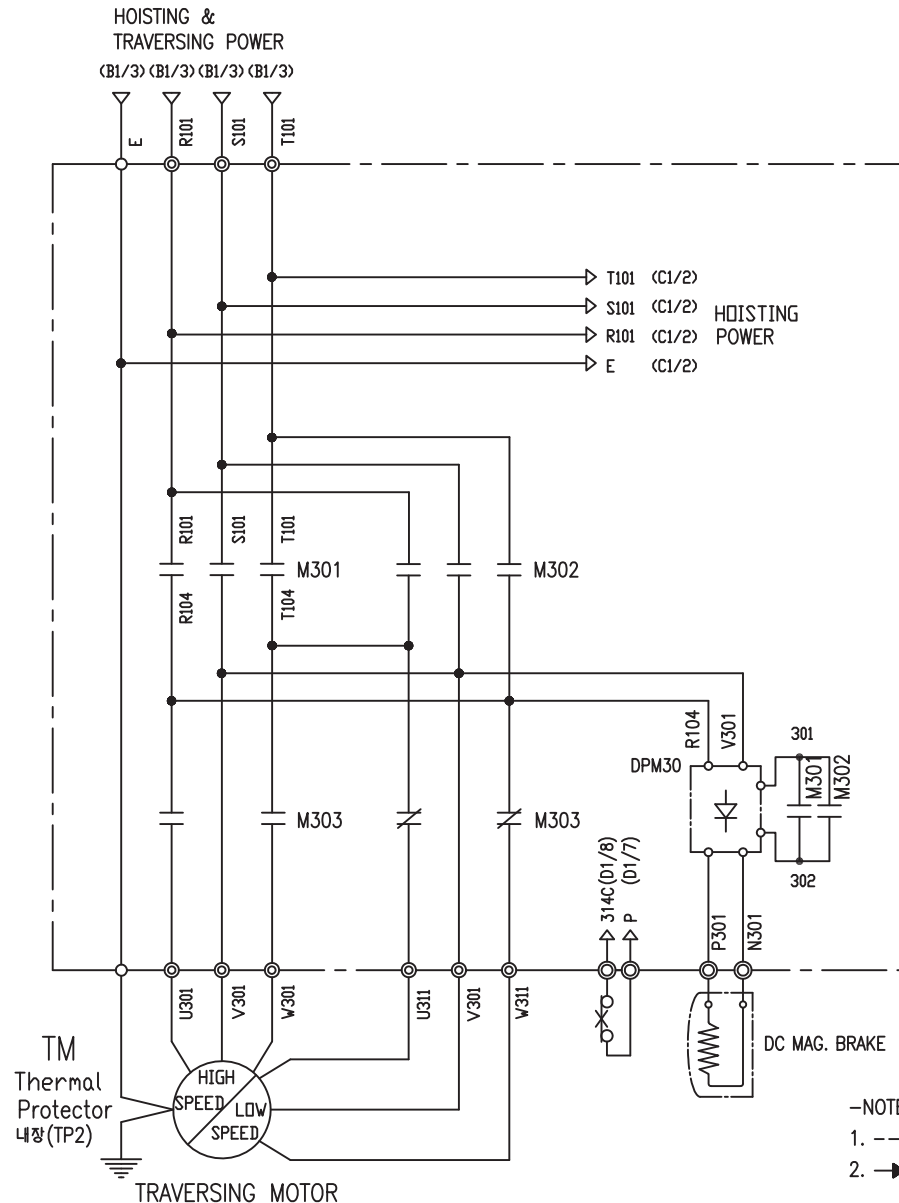

----- PENDANT SWITCH -----

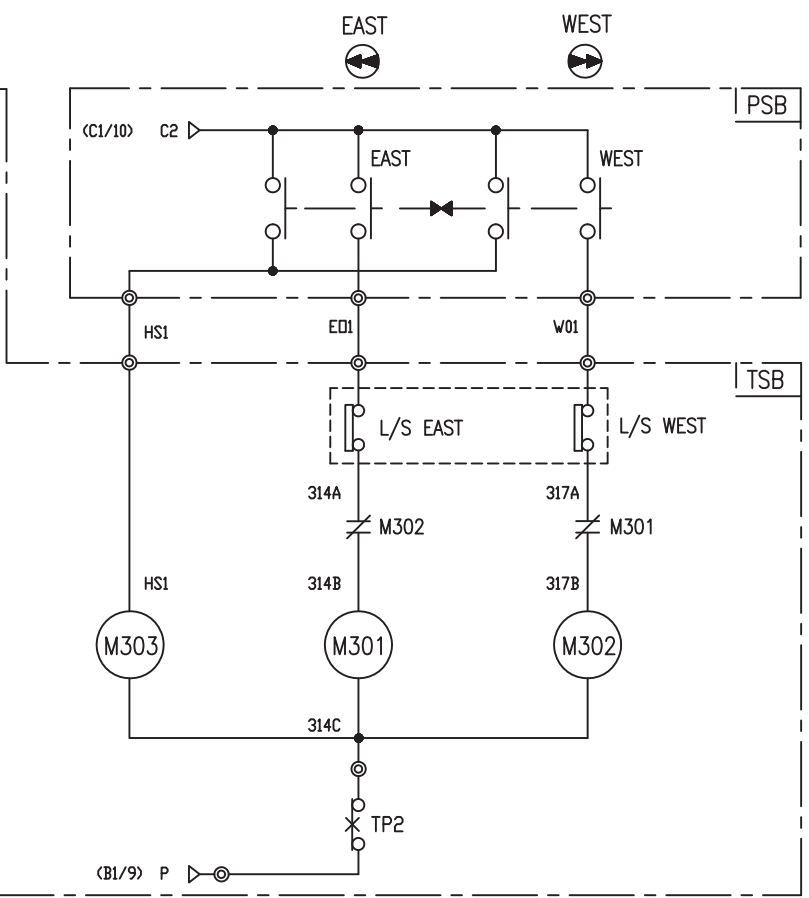

-NOTE-
1. ----- : MARKER OWNER SCOPE
2. : Mechanical Interlock

TITLE TRAVERSING MOTOR POWER & CONTROL CIRCUIT DIAGRAM						PROJECTION	
WORK NO 606						WORK NAME DHDAM(HOOK간 거리 1M이하)	
220V, 380V, 440V, 460V, 480V						SCALE 1/1	Q' TY 1
DRAWN LEE.G.H	CHECKED	REVIEWED	APPROVED	MODEL	DHDAM		
2010.07.30				CODE NO			
 L K HOIST CO., LTD.							

SPECIFICATION	MAGNET CONTACT		Thermal Protector	SILICON RECTIFIER					TRAVERSING MOTOR
SYMBOLS	M301, M302, M303		TP2	DPM30					TM
DESCRIPTION	GMC12	DMC12	17AM032	AC220V	AC380V	AC440V	AC460V	AC480V	0.4/0.14KW *4/12P
MAKER	LS	DONGA	Texas Instruments	DC99V	DC171V	DC198V	DC207V	DC216V	

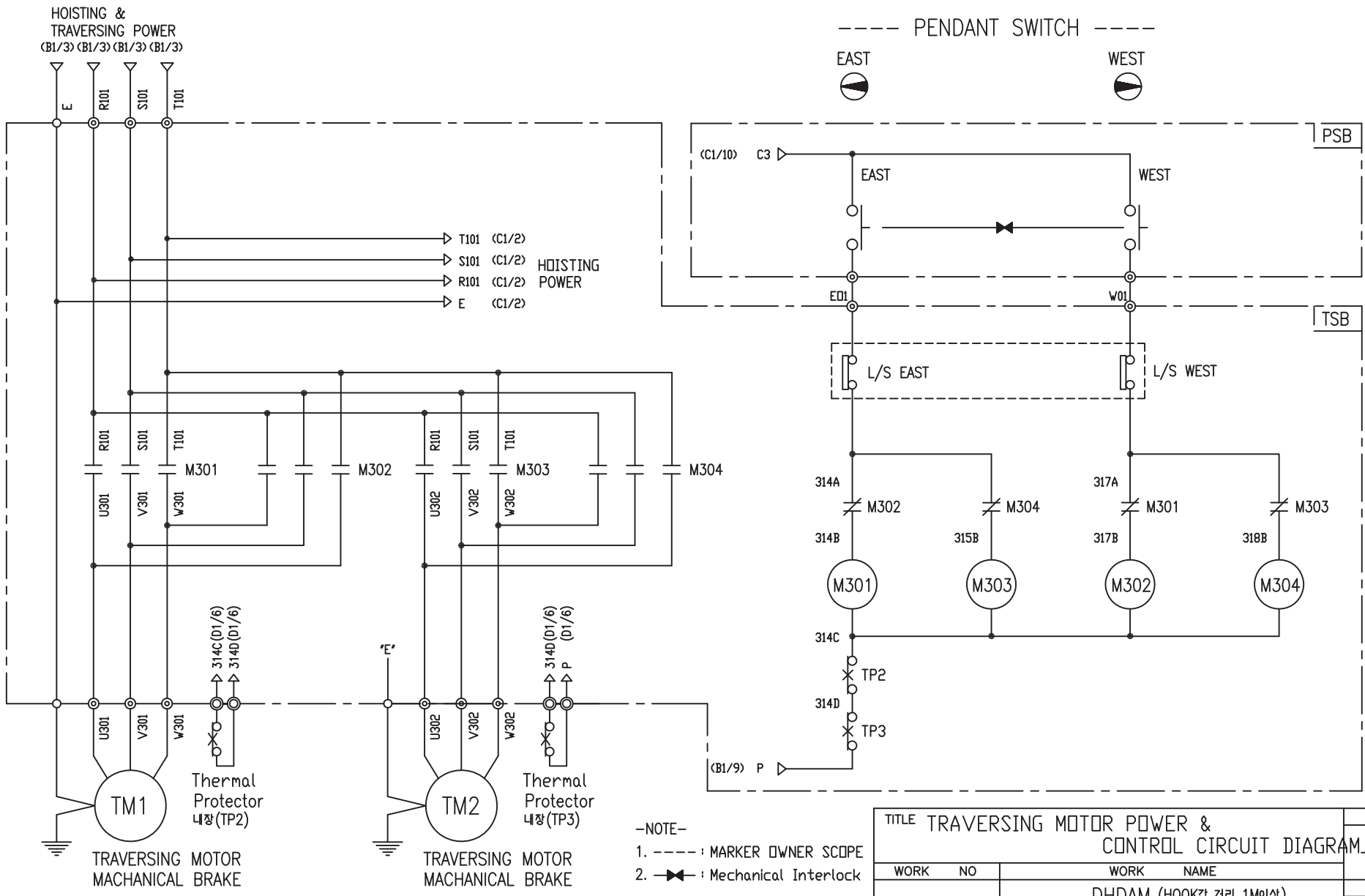

-NOTE-

1. ----- : MARKER OWNER SCOPE

2. —|—|— : Mechanical Interlock

TITLE TRAVERSING MOTOR POWER & CONTROL CIRCUIT DIAGRAM						PROJECTION	
WORK NO		WORK NAME				SCALE	
607		DHDAM (HOOK간 거리 1M이상)				Q' TY	
		220V, 380V, 440V, 460V, 480V				1/1	
DRAWN	CHECKED	REVIEWED	APPROVED	MODEL	DHDAM		
LEE.G.H				CODE NO			
2010.07.30							
L K HOIST CO., LTD.							

SPECIFICATION	MAGNET CONTACT	Thermal Protector	TRAVERSING MOTOR	
SYMBOLS	M301, M302, M303, M304	TP2, TP3	TM1, TM2	
DESCRIPTION	GMC12	DMC12	0.4KW *4P(2set)	0.3KW *6P(2set)
MAKER	LS	DONGA	Texas Instruments	
			LK	

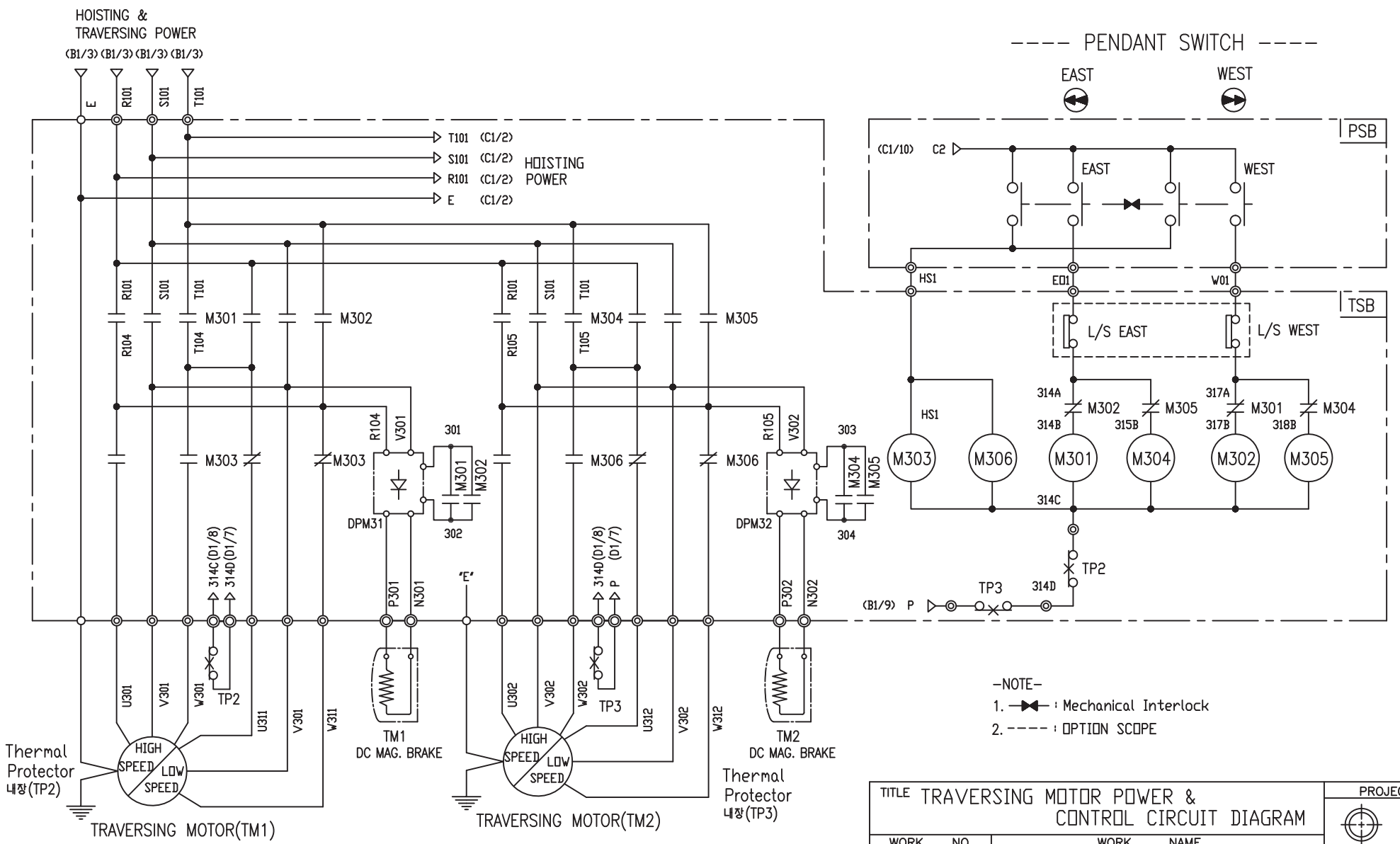

-NOTE-

1. : Mechanical Interlock
2. - - - - : OPTION SCOPE

SPECIFICATION	MAGNET CONTACT	Thermal Protector	SILICON RECTIFIER				TRAVERSING MOTOR
SYMBOLS	M301, M302, M303 M304, M305, M306	TP2, TP3	DPM31, DPM32				TM1, TM2
DESCRIPTION	GMC12	DMC12	17AM032				0.4/0.14KW ※4/12P (2set)
MAKER	LS	DONGA	Texas Instruments				
			AC220V	AC380V	AC440V	AC460V	AC480V
			DC99V	DC171V	DC198V	DC207V	DC216V
			LK				LK

TITLE TRAVERSING MOTOR POWER & CONTROL CIRCUIT DIAGRAM						PROJECTION	
WORK NO		WORK NAME					
608		DHDAM (HOOK간 거리 1M이상)				SCALE	
		220V, 380V, 440V, 460V, 480V				Q' TY	
		1/1				1	
DRAWN	CHECKED	REVIEWED	APPROVED	MODEL	DHDAM		
LEE.G.H				CODE NO			
2010.07.30							
L K HOIST CO., LTD.							

SCHEDULE OF TECHNICAL DATA

1. SERVICE	HOISTING
2. MANUFACTURE	LK HOIST CO. LTD
3. MOTOR MODEL NO	1.8 - 4 - 48
4. RATED POWER	1.8 KW × 4 P
5. RATED VOLTAGE AND FREQUENCY	480 V 60HZ
6. MOTOR TYPE	SQUIRREL CAGE ROTOR TYPE
7. RATING	30 MIN
8. LOCATION	IN-DOOR , OUTDOOR
9. INSULATION CLASS	B
10. DESIGN TEMPERATURE RISE (BY RESISTANCE)	80℃
11. FULL LOAD SPEED	1740 RPM
12. FULL LOAD CURRENT	4.3 A
13. STARTING CURRENT AT RATED VOLTAGE	21.5 A
14. MINIMUM STARTING VOLTAGE	397 V
15. EFFICIENCY AT 100% RATED LOAD	72.3 %
16. POWER FACTOR AT 100% RATED LOAD	69.6 %
17. STARTING TORQUE	244 %
18. TYPE OF ENCLOSURE	전폐형
19. TYPE OF BEARING	PL : 6008DD OPL : 6207ZZ
20. MOUNTING	VERTICAL
21. MAXIMUM AMBIENT TEMPURE	40℃
22. BEARING LUBRICATION	GREASE
23. STARTING METHOD	FULL VOLTAGE

SCHEDULE OF TECHNICAL DATA

1. SERVICE	TRAVERSING
2. MANUFACTURE	LK HOIST CO. LTD
3. MOTOR MODEL NO	0.4 - 4 - 48
4. RATED POWER	0.4 KW × 4 P
5. RATED VOLTAGE AND FREQUENCY	480 V 60HZ
6. ROTOR TYPE	SQUIRREL CAGE ROTOR TYPE
7. RATING	15 MIN
8. LOCATION	IN-DOOR , OUTDOOR
9. INSULATION CLASS	B
10. DESIGN TEMPERATURE RISE (BY RESISTANCE)	100℃
11. FULL LOAD SPEED	1710 RPM
12. FULL LOAD CURRENT	1.38 A
13. STARTING CURRENT AT RATED VOLTAGE	6.5 A
14. MINIMUM STARTING VOLTAGE	432 V
15. EFFICIENCY AT 100% RATED LOAD	60 %
16. POWER FACTOR AT 100% RATED LOAD	58 %
17. STARTING TORQUE	249 %
18. TYPE OF ENCLOSURE	전폐형
19. TYPE OF BEARING	PL : 6202DD OPL : 6004ZZ
20. MOUNTING	VERTICAL
21. MAXIMUM AMBIENT TEMPERATURE	40℃
22. BEARING LUBRICATION	GREASE
23. STARTING METHOD	FULL VOLTAGE

SCHEDULE OF TECHNICAL DATA

1. SERVICE	TRAVERSING
2. MANUFACTURE	LK HOIST CO. LTD
3. MOTOR MODEL NO	0.3 - 6 - 48
4. RATED POWER	0.3 KW × 6 P
5. RATED VOLTAGE AND FREQUENCY	480 V 60HZ
6. ROTOR TYPE	SQUIRREL CAGE ROTOR TYPE
7. RATING	15 MIN
8. LOCATION	IN-DOOR , OUTDOOR
9. INSULATION CLASS	B
10. DESIGN TEMPERATURE RISE (BY RESISTANCE)	100℃
11. FULL LOAD SPEED	1140 RPM
12. FULL LOAD CURRENT	1.2 A
13. STARTING CURRENT AT RATED VOLTAGE	6.57 A
14. MINIMUM STARTING VOLTAGE	432 V
15. EFFICIENCY AT 100% RATED LOAD	56 %
16. POWER FACTOR AT 100% RATED LOAD	53 %
17. STARTING TORQUE	249 %
18. TYPE OF ENCLOSURE	전폐형
19. TYPE OF BEARING	PL : 6008DD OPL : 6207ZZ
20. MOUNTING	VERTICAL
21. MAXIMUM AMBIENT TEMPERATURE	40℃
22. BEARING LUBRICATION	GREASE
23. STARTING METHOD	FULL VOLTAGE

SCHEDULE OF TECHNICAL DATA

1. SERVICE	TRAVERSING
2. MANUFACTURE	LK HOIST CO. LTD
3. MOTOR MODEL NO	0.4/0.14 - 4/12 - 48
4. RATED POWER	0.4/0.14 KW × 4/12 P
5. RATED VOLTAGE AND FREQUENCY	480 V 60HZ
6. MOTOR TYPE	SQUIRREL CAGE ROTOR TYPE
7. RATING	15 MIN
8. LOCATION	IN-DOOR , OUTDOOR
9. INSULATION CLASS	B
10. DESIGN TEMPERATURE RISE (BY RESISTANCE)	100℃
11. FULL LOAD SPEED	1710 / 550 RPM
12. FULL LOAD CURRENT	1.38 / 0.9 A
13. STARTING CURRENT AT RATED VOLTAGE	6.9 / 4.5 A
14. MINIMUM STARTING VOLTAGE	432 V
15. EFFICIENCY AT 100% RATED LOAD	61 / 48.3 %
16. POWER FACTOR AT 100% RATED LOAD	57 / 41.3 %
17. STARTING TORQUE	233 / 230 %
18. TYPE OF ENCLOSURE	전폐형
19. TYPE OF BEARING	PL : 6008DD OPL : 6207ZZ
20. MOUNTING	VERTICAL
21. MAXIMUM AMBIENT TEMPURE	40℃
22. BEARING LUBRICATION	GREASE
23. STARTING METHOD	FULL VOLTAGE