

-NOTE-
1. : Mechanical Interlock

| SPECIFICATION | MAGNET CONTACT | SILICON RECTIFIER | LOAD LIMITER | Thermal Protector | HOIST MOTOR |
|---------------|----------------|-------------------|--------------|-------------------|-------------|
| SYMBOLS | M101, M102 | DPM30 | - | TP1 | HM |
| DESCRIPTION | GMC12 DMC12 | AC220V/DC99V | LKDL-501 | 17AM032 | 1.5Kw * 6P |
| MAKER | LS DONGA | LK | LK | Texas Instruments | LK |

| TITLE | | | | | PROJECTION | |
|---------------------------------------|-----------|----------|----------|---------|------------|-------|
| HOIST POWER & CONTROL CIRCUIT DIAGRAM | | | | | | |
| WORK NO. | WORK NAME | | | | SCALE | Q' TY |
| 603 | LDUH | | | | 1/1 | 1 |
| 380V | | | | | | |
| DRAWN | CHECKED | REVIEWED | APPROVED | MODEL | | |
| LEE.G.H | | | | CODE NO | | |
| 2010.10.13 | | | | | | |
| L K HOIST CO., LTD. | | | | | | |

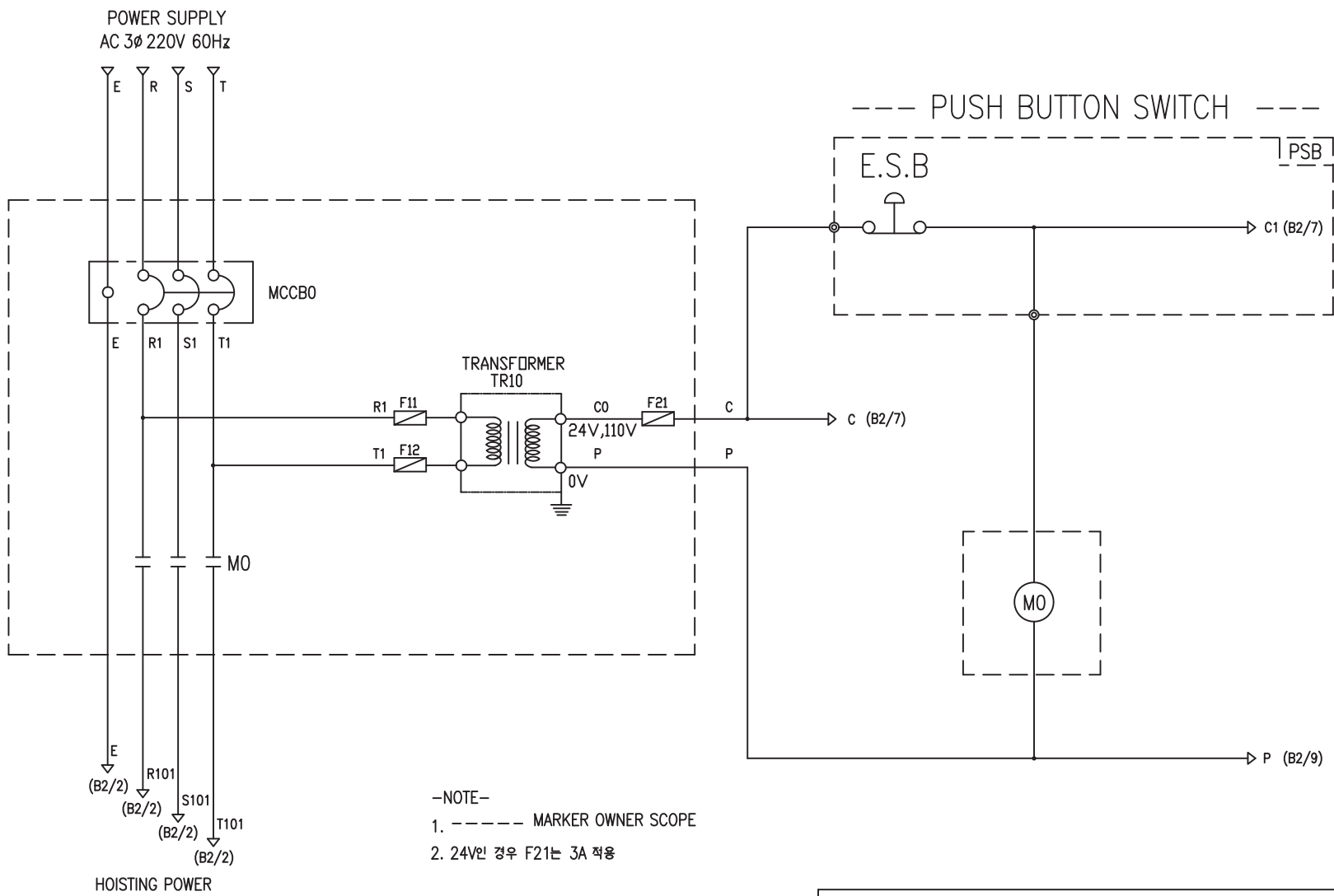

-NOTE-

1. ----- MARKER OWNER SCOPE
2. 24V인 경우 F21는 3A 적용

| SPECIFICATION | NO FUSE BREAKER | MAGNET CONTACT | TRANSFORMER | FUZE |
|---------------|-----------------|----------------|-------------|---------------|
| SYMBOLS | MCCB0 | M0 | TR10 | F11, F12, F21 |
| DESCRIPTION | 220V | 20A | 30VA | 1A |
| | 380V | 10A | | |
| | 440V | 10A | | |
| | 460V | 10A | | |
| | 480V | 10A | | |
| MAKER | LS | LS | DONGA | LK |

| | | | | | |
|---|-----------|----------|----------|----------------|--|
| TITLE MAIN POWER & CONTROL CIRCUIT DIAGRAM | | | | PROJECTION | |
| WORK NO | WORK NAME | | | | |
| 604 | LDUH | | SCALE | Q' TY | |
| 220V, 380V, 440V, 460V, 480V | | | 1/1 | 1 | |
| DRAWN | CHECKED | REVIEWED | APPROVED | DRAWING NO | |
| LEE.G.H | | | | CODE NO | |
| 2010.10.13 | | | | | |
| L K HOIST CO., LTD. | | | | | |

HOISTING POWER

(A2/3)(A2/3)(A2/3)(A2/3)

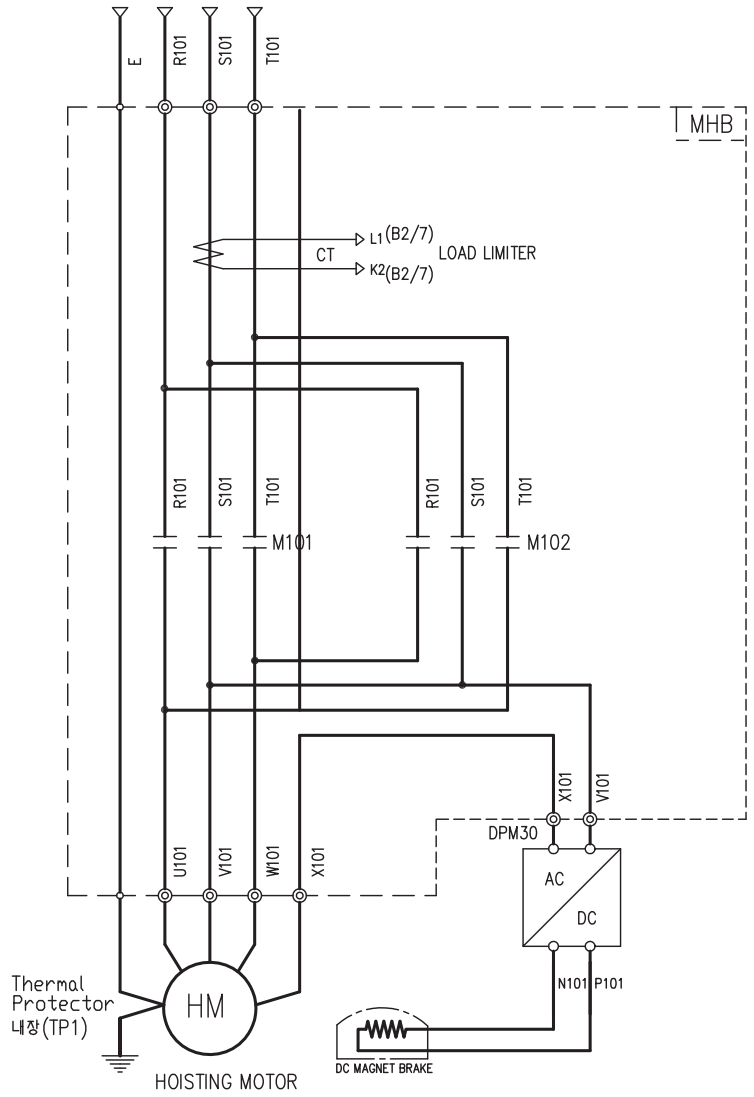

-- PUSH BUTTON SWITCH --

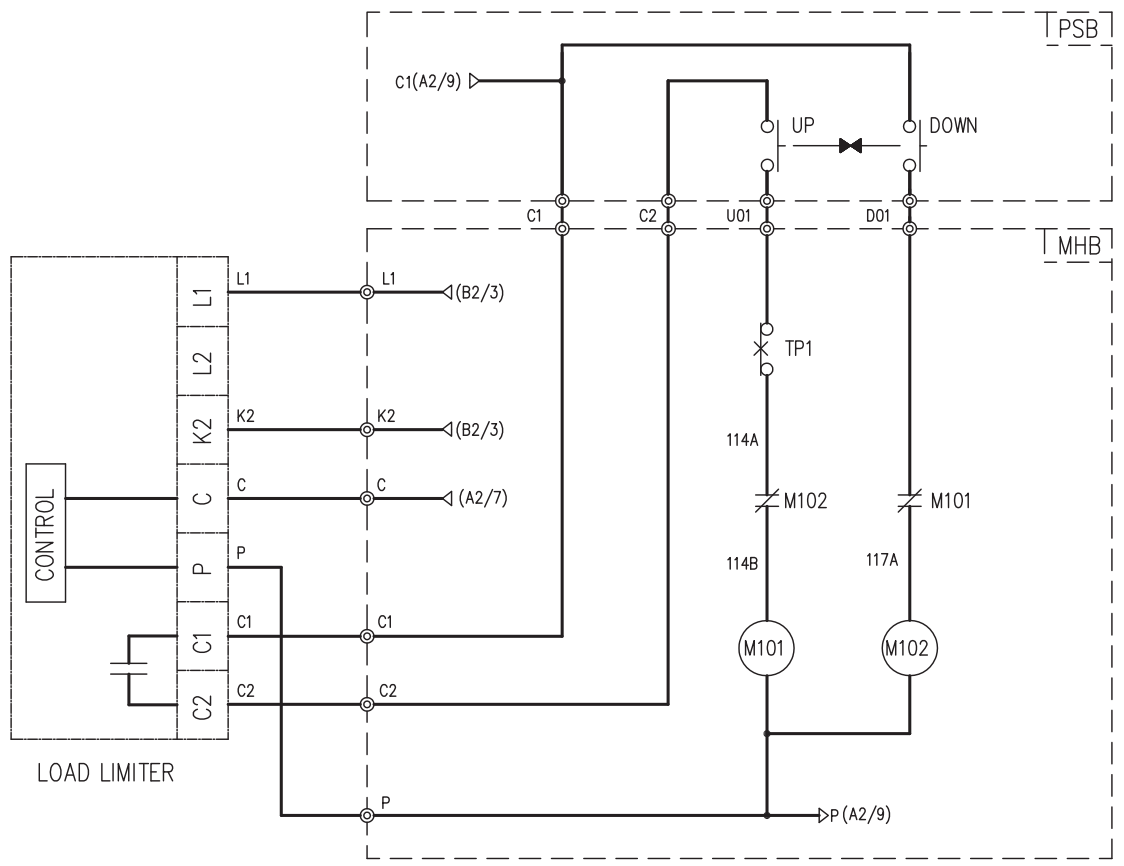
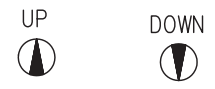

- NOTE-
- : Mechanical Interlock
 - : Marker owner scope

| | | | | | | | |
|---------------------------------------|-----------|----------|----------|---------|--|------------|-------|
| TITLE | | | | | | PROJECTION | |
| HOIST POWER & CONTROL CIRCUIT DIAGRAM | | | | | | | |
| WORK NO | WORK NAME | | | | | SCALE | Q' TY |
| 606 | LDUH | | | | | 1/1 | 1 |
| 380V | | | | | | | |
| DRAWN | CHECKED | REVIEWED | APPROVED | MODEL | | | |
| LEE.G.H | | | | CODE NO | | | |
| 2010.10.13 | | | | | | | |
| L K HOIST CO., LTD. | | | | | | | |

| SPECIFICATION | MAGNET CONTACT | | SILICON RECTIFIER | LOAD LIMITER | Thermal Protector | HOIST MOTOR |
|---------------|----------------|-------|-------------------|--------------|-------------------|-------------|
| SYMBOLS | M101, M102 | | DPM30 | - | TP1 | HM |
| DESCRIPTION | GMC12 | DMC12 | AC220V/DC99V | LKDL-501 | 17AM032 | 1.5Kw * 6P |
| MAKER | LS | DONGA | LK | LK | Texas Instruments | LK |

SCHEDULE OF TECHNICAL DATA

| | |
|---|-----------------------------|
| 1. SERVICE | HOISTING |
| 2. MANUFACTURE | LK HOIST CO. LTD |
| 3. MOTOR MODEL NO | 1.5 - 6 - 38 |
| 4. RATED POWER | 1.5 KW × 6 P |
| 5. RATED VOLTAGE AND FREQUENCY | 380 V 60HZ |
| 6. MOTOR TYPE | SQUIRREL CAGE ROTOR TYPE |
| 7. RATING | 30 MIN |
| 8. LOCATION | IN-DOOR , OUTDOOR |
| 9. INSULATION CLASS | B |
| 10. DESIGN TEMPERATURE RISE (BY RESISTANCE) | 80℃ |
| 11. FULL LOAD SPEED | 1150 RPM |
| 12. FULL LOAD CURRENT | 5.2 A |
| 13. STARTING CURRENT AT RATED VOLTAGE | 23.4 A |
| 14. MINIMUM STARTING VOLTAGE | 347 V |
| 15. EFFICIENCY AT 100% RATED LOAD | 68.5 % |
| 16. POWER FACTOR AT 100% RATED LOAD | 64 % |
| 17. STARTING TORQUE | 244 % |
| 18. TYPE OF ENCLOSURE | 전폐형 |
| 19. TYPE OF BEARING | PL : 6008DD OPL : 6207ZZ |
| 20. MOUNTING | VERTICAL |
| 21. MAXIMUM AMBIENT TEMPURE | 40℃ |
| 22. BEARING LUBRICATION | GREASE |
| 23. STARTING METHOD | FULL VOLTAGE |