

ON ㉔MD

L K HOIST

NO	DESCRIPTION	SIZE	MAT' L	Q' TY	WT (kg)	REMARKS

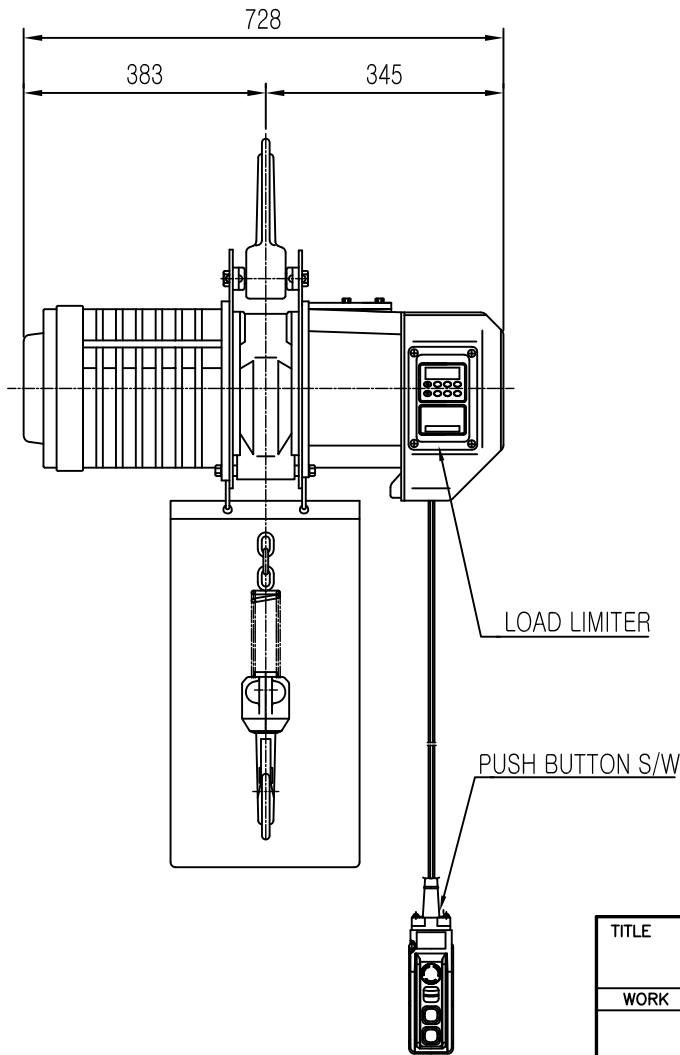
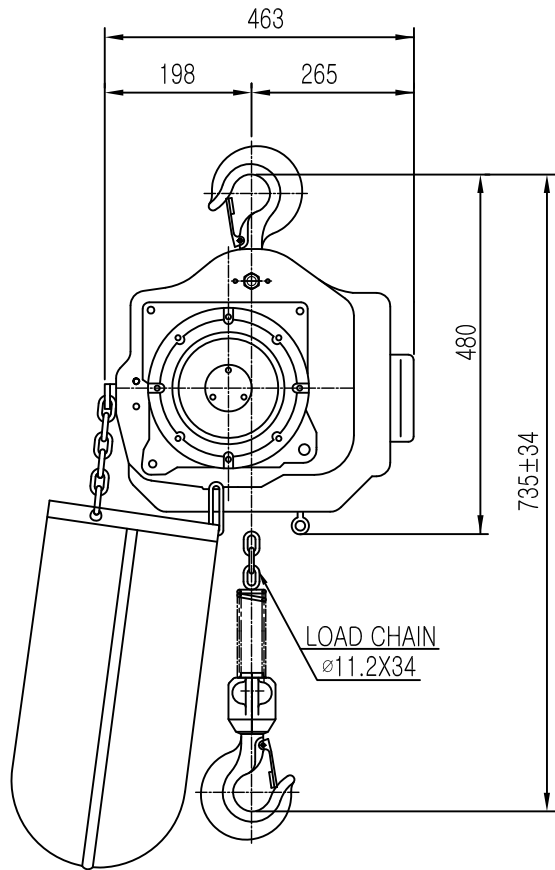

SPECIFICATION		
RATED LOAD	1.9	TON
TESTING LOAD	2.375	TON
LIFTING HEIGHT	50	M
HOISTING	SPEED	8.1/2.7 M/MIN
	MOTOR	4.4/2.2 KW x 2/6P
TRAVERSING	SPEED	- M/MIN
	MOTOR	- KW x - SET
POWER SUPPLY	AC220,380,440,460,480 V x 3øx60Hz	
OPERATING METHOD	P.B type ON . FL	
LOAD CHAIN	ø11.2 x 34 (1 FALL)	
WIEGHT	250 KG	

NOTE)

- 1) 점검 설비를 갖출것.
- 2) 인허가 서류를 완성검사시 제출할것.

TITLE				PROJECTION	
DB-1.9S ELECTRIC CHAIN HOIST					
WORK NO	WORK NAME			SCALE	Q' TY
	HOOK TYPE			N S	1
DRAWN	CHECKED	REVIEWED	APPROVED	DRAWING NO	
김 창 기					
2010.07.27					

REV.NO	DATE	REVISION	DESCRIPTION	DRAWN	CHECKED	APPROVED

L K HOIST

ON 3MD

NO	DESCRIPTION	SIZE	MAT' L	Q' TY	WT (kg)	REMARKS

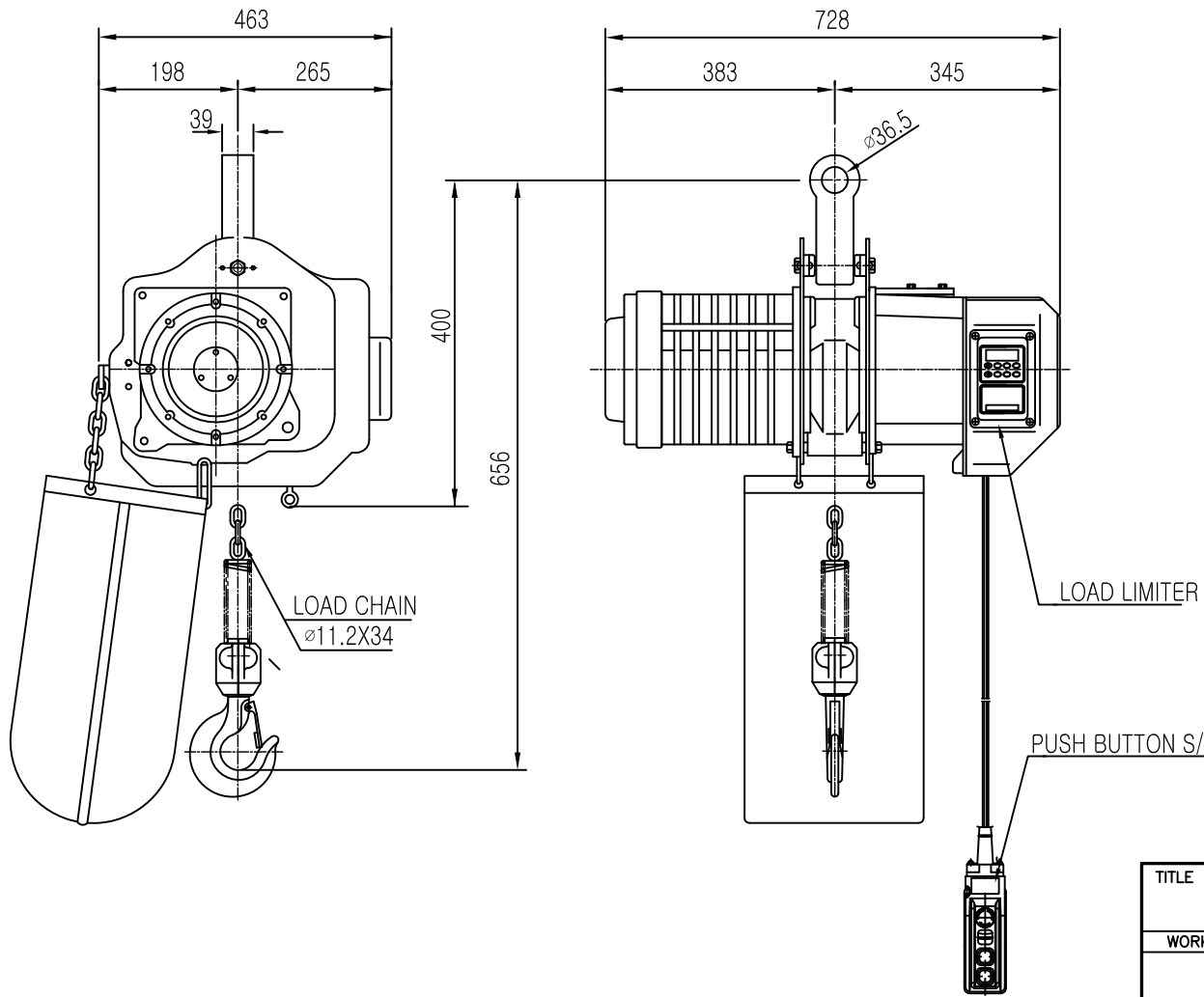

SPECIFICATION	
RATED LOAD	1.9 TON
TESTING LOAD	2.375 TON
LIFTING HEIGHT	50 M
HOISTING	SPEED 8.1/2.7 M/MIN
	MOTOR 4.4/2.2 KW x 2/6P
TRAVERSING	SPEED - M/MIN
	MOTOR - KW x - SET
POWER SUPPLY	AC220,380,440,460,480V x 3øx60Hz
OPERATING METHOD	P.B type ON . FL
LOAD CHAIN	ø11.2 x 34 (1 FALL)
WIEGHT	250 KG

NOTE)
 1) 점검 설비를 갖출것.
 2) 인허가 서류를 완성검사시 제출할것.

TITLE				PROJECTION	
DB-1.9S ELECTRIC CHAIN HOIST					
WORK NO	WORK NAME			SCALE	Q' TY
	CONNECTOR TYPE			N S	1
DRAWN	CHECKED	REVIEWED	APPROVED	DRAWING NO	
김 창 기					
2010.07.27					

REV.NO	DATE	REVISION	DESCRIPTION	DRAWN	CHECKED	APPROVED

LK L K HOIST CO., LTD.

L K HOIST

ON GMD

NO	DESCRIPTION	SIZE	MAT L	Q' TY	WT (kg)	REMARKS

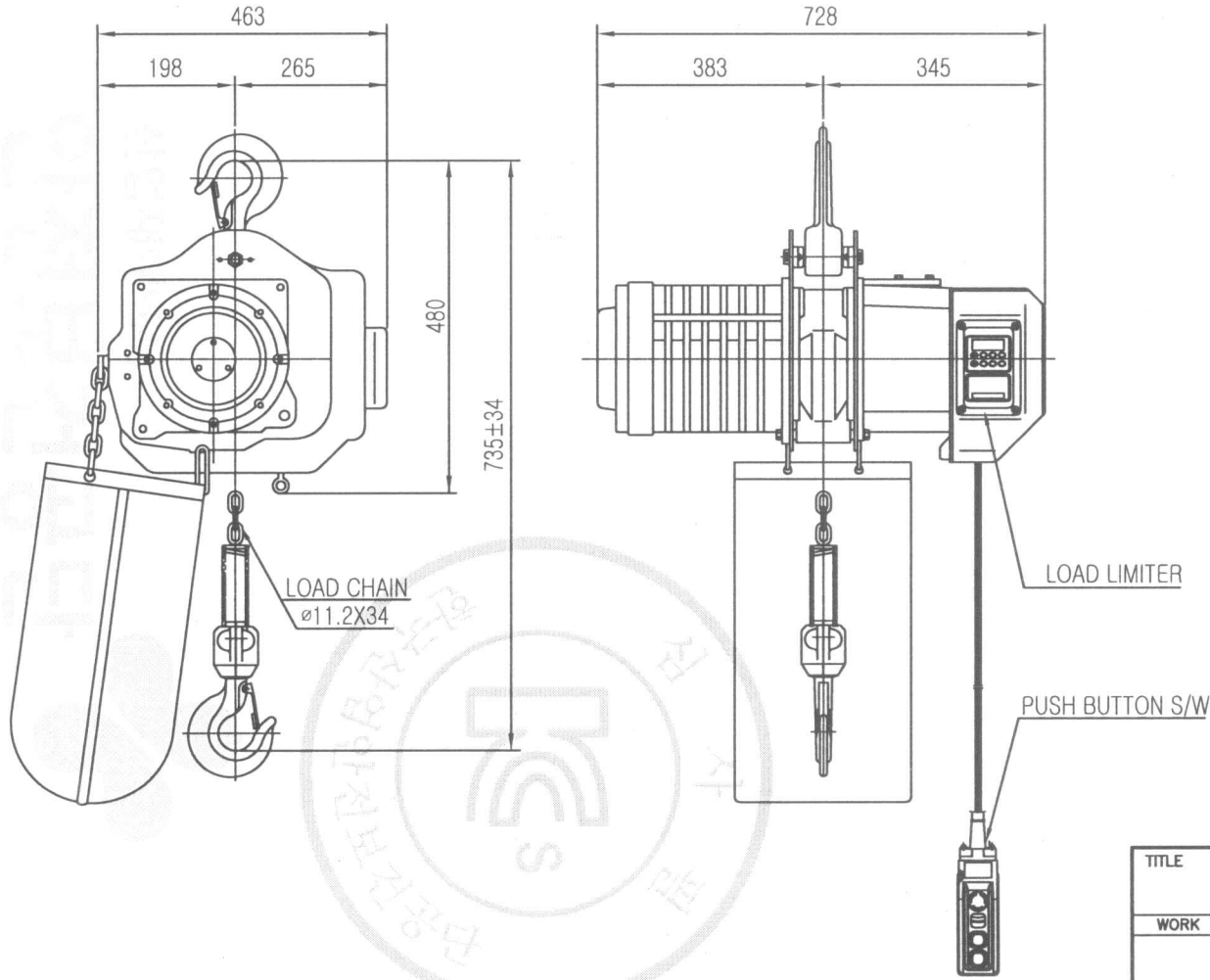

SPECIFICATION	
RATED LOAD	1.9 TON
TESTING LOAD	2.375 TON
LIFTING HEIGHT	50 M
HOISTING	SPEED 8.1/2.7 M/MIN
	MOTOR 4.4/2.2 KW x 2/6P
TRAVERSING	SPEED - M/MIN
	MOTOR - KW x - SET
POWER SUPPLY	AC220,380,440,460,480V x 3øx60Hz
OPERATING METHOD	P.B type ON . FL
LOAD CHAIN	ø11.2 x 34 (1 FALL)
WIEGHT	250 KG

NOTE)
 1) 점검 설비를 갖출것.
 2) 인허가 서류를 완성검사시 제출할것.

물품별 제 및 배포금지

REV.NO	DATE	REVISION	DESCRIPTION	DRAWN	CHECKED	APPROVED

TITLE					PROJECTION	
DB-1.9S ELECTRIC CHAIN HOIST						
WORK NO	WORK NAME				SCALE	Q' TY
	HOOK TYPE				N S	1
DRAWN	CHECKED	REVIEWED	APPROVED	DRAWING NO		
김창기						
2010.07.27						
L K HOIST CO., LTD.						

ON GMD

L K HOIST

NO	DESCRIPTION	SIZE	MAT L	Q' TY	WT (kg)	REMARKS

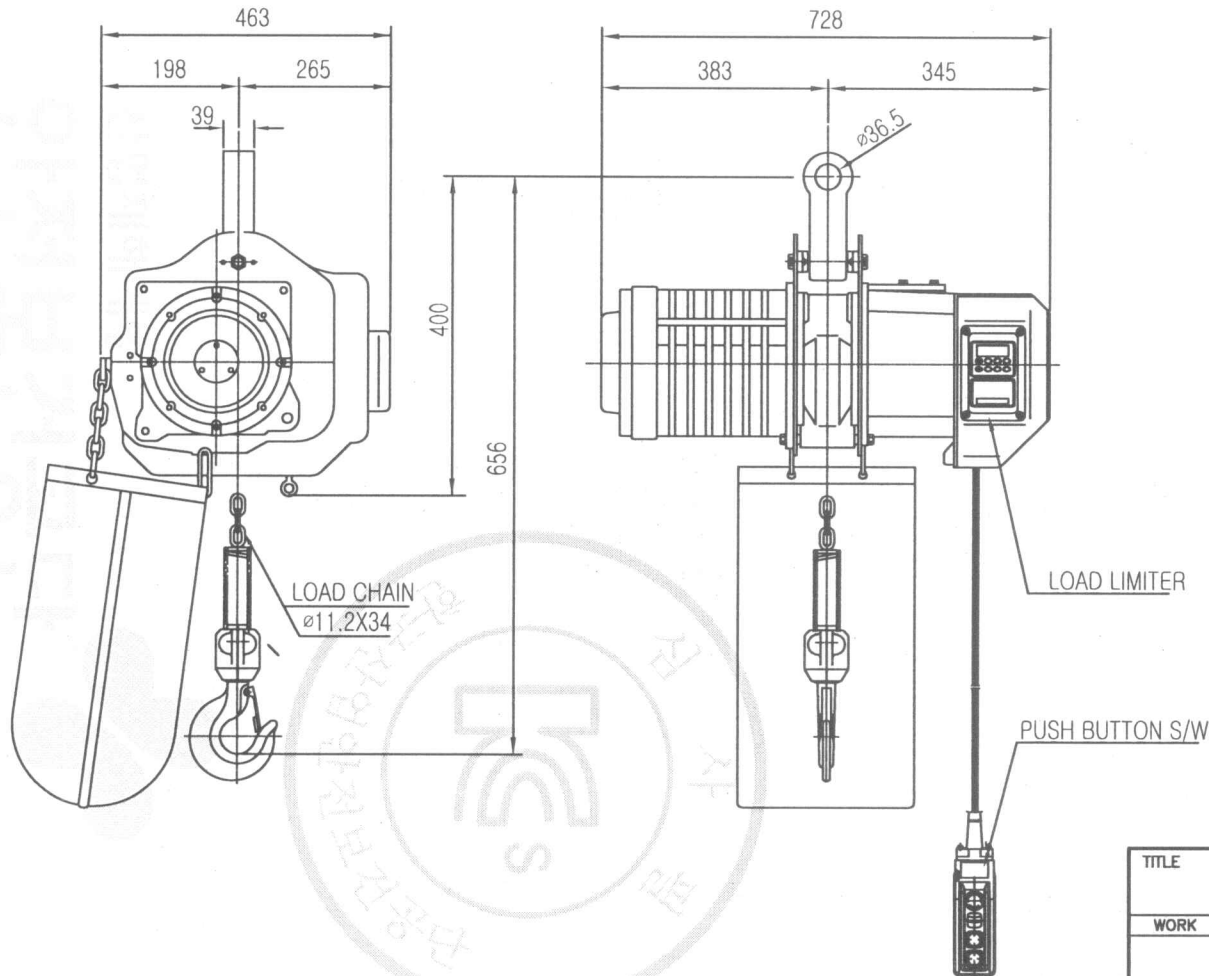

SPECIFICATION		
RATED LOAD	1.9	TON
TESTING LOAD	2.375	TON
LIFTING HEIGHT	50	M
HOISTING	SPEED	8.1/2.7 M/MIN
	MOTOR	4.4/2.2 KW x 2/6P
TRAVERSING	SPEED	- M/MIN
	MOTOR	- KW x - SET
POWER SUPPLY	AC220,380,440,460,480V x 3øx60Hz	
OPERATING METHOD	P.B type ON . FL	
LOAD CHAIN	ø11.2 x 34 (1 FALL)	
WIEGHT	250 KG	

NOTE)

- 1) 점검 설비를 갖추것.
- 2) 인허가 서류를 완성검사시 제출할것.

공법복제 및 배포금지

REV.NO	DATE	REVISION	DESCRIPTION	DRAWN	CHECKED	APPROVED

TITLE					PROJECTION		
DB-1.9S ELECTRIC CHAIN HOIST							
WORK NO	WORK NAME				SCALE	Q' TY	
	CONNECTOR TYPE				N S	1	
DRAWN	CHECKED	REVIEWED	APPROVED	DRAWING NO			
김창기							
2010.07.27							