

POWER CIRCUIT
TRAVELLING POWER SUPPLY SYSTEM

ADDRESS NO.
A1

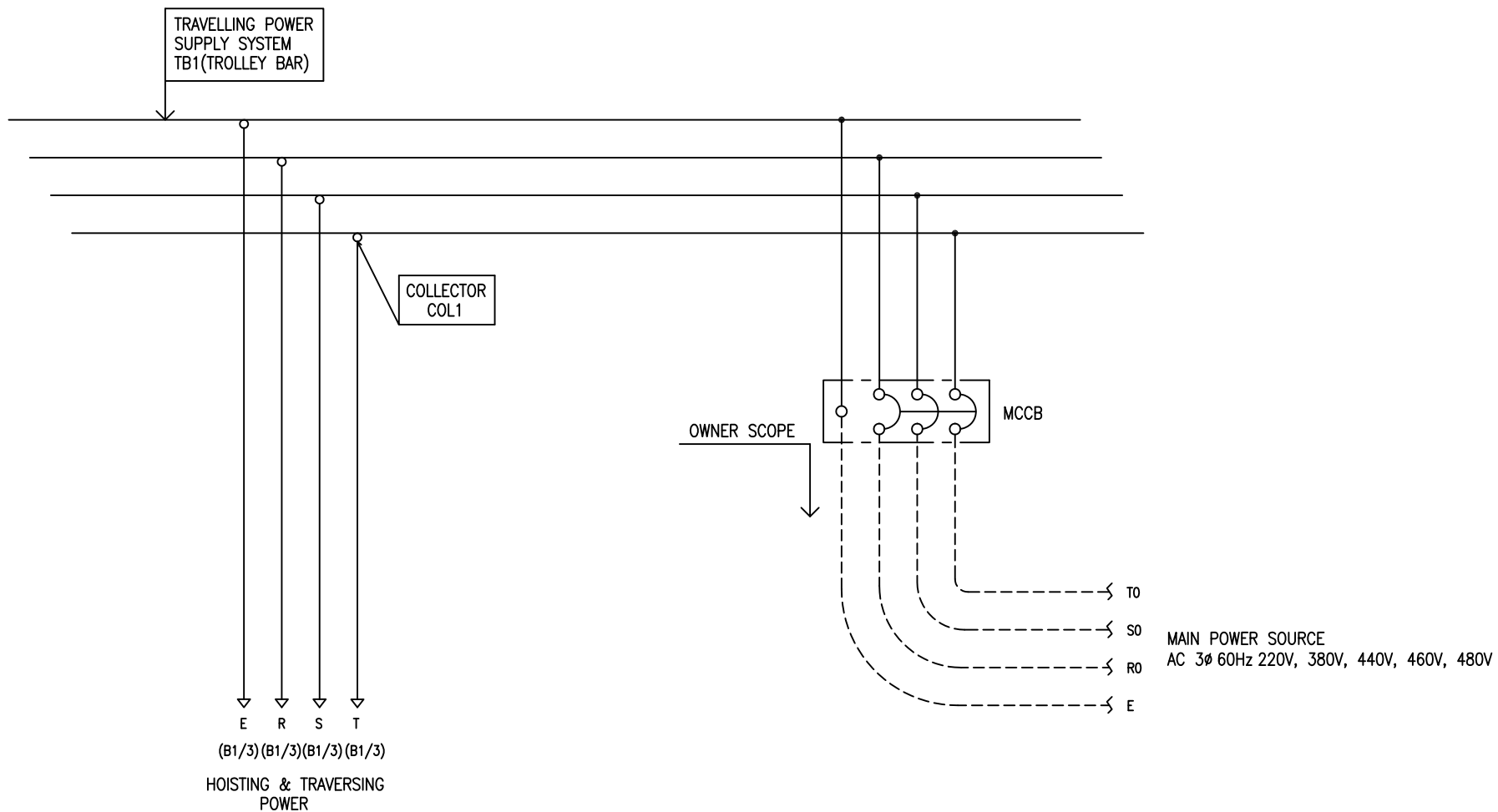

-NOTE-

- 1. - - - - MARKED OWNER SCOPE
- 2. ——— MARKED CRAIN MAKER SCOPE

TITLE MAIN POWER CIRCUIT DIAGRAM1				PROJECTION 	
WORK NO 601	WORK NAME DAM			SCALE 1/1	Q' TY 1
DRAWN LEE G.H. 2019.08.22		CHECKED	REVIEWED	APPROVED	DRAWING NO DAM
				CODE NO	

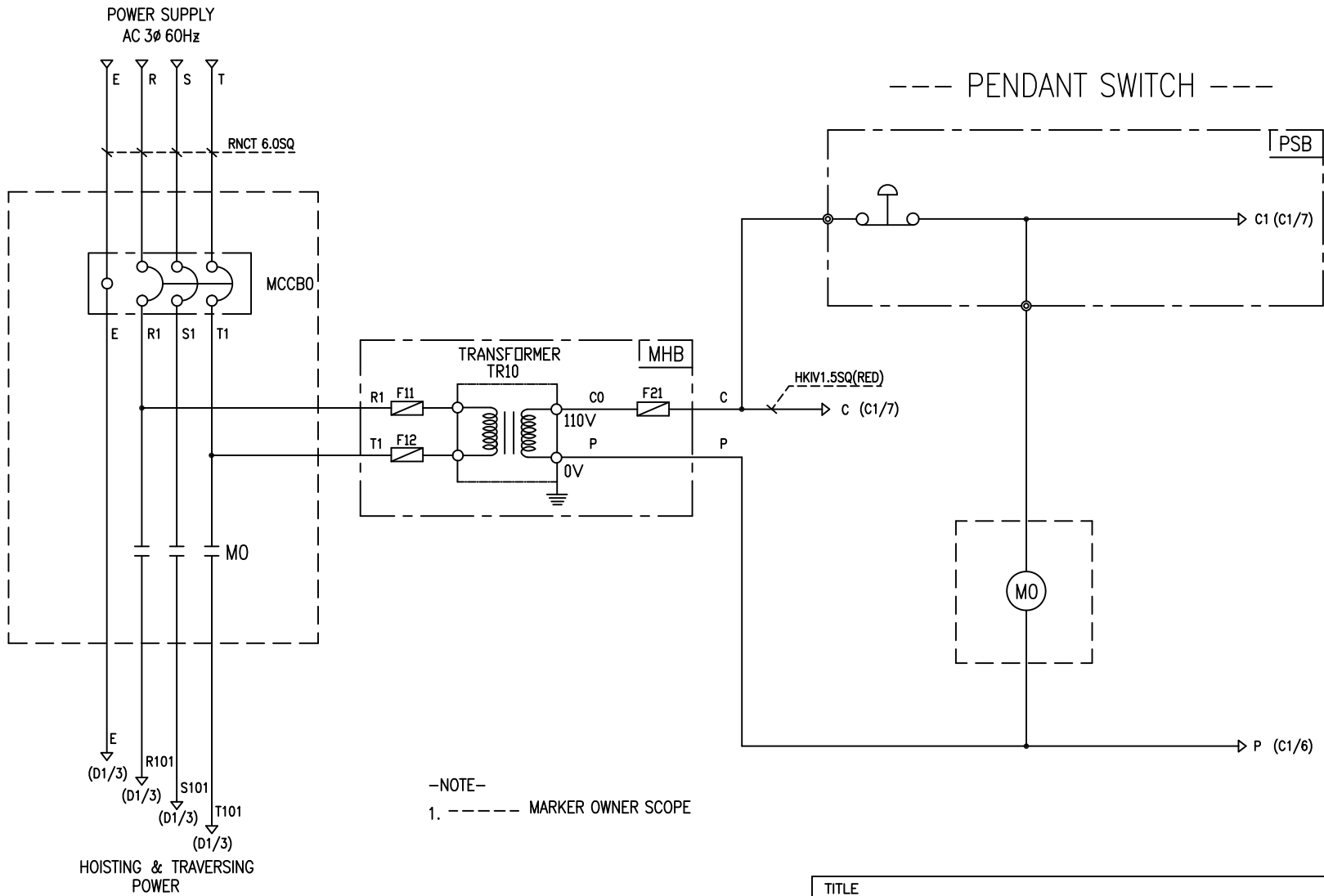

HOISTING & TRAVERSING POWER

SPECIFICATION	NO FUSE BREAKER	MAGNET CONTACT	TRANSFORMER	FUZE		
SYMBOLS	MCCBO	MO	TR10	F11, F12, F21		
DESCRIPTION	220V	50A	GMC22	DMC-22	60VA	1A
	380V	30A				
	440V	20A				
	460V	20A				
	480V	20A				
MAKER	LS	LS	DONGA	LK	-	

TITLE MAIN POWER & CONTROL CIRCUIT DIAGRAM						PROJECTION	
WORK NO 602		WORK NAME DAM				SCALE 1/1	Q' TY 1
DRAWN LEE.G.H	CHECKED	REVIEWED	APPROVED	MODEL	DAM		
2019.08.22				CODE NO			
L K HOIST CO., LTD.							

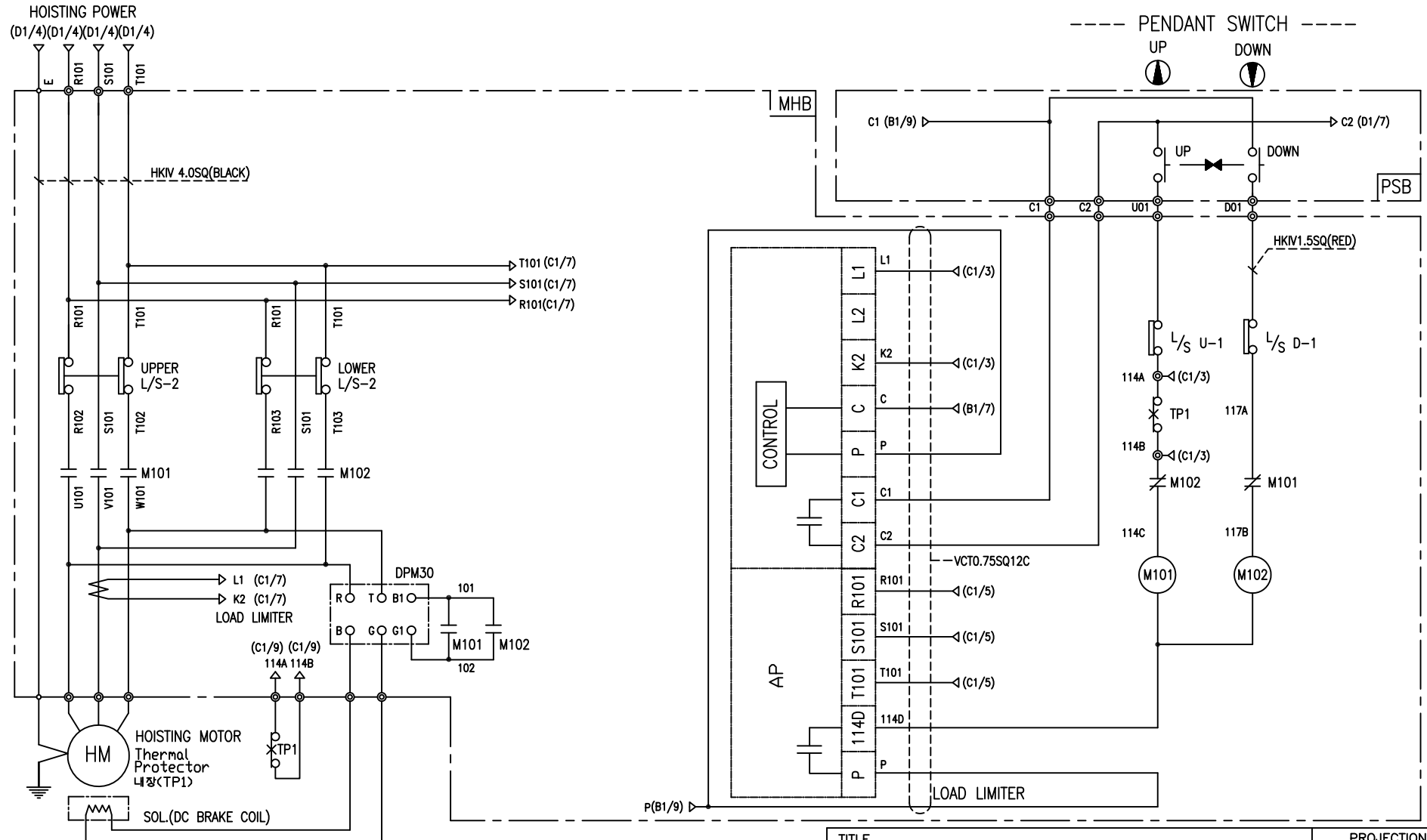

-NOTE-
1. : Mechanical Interlock

TITLE HOIST POWER & CONTROL CIRCUIT DIAGRAM						PROJECTION 	
WORK NO 603		WORK NAME DAM				SCALE 1/1	Q' TY 1
220V, 440V, 460V, 480V							
DRAWN LEE.G.H	CHECKED	REVIEWED	APPROVED	MODEL	DAM		
2019.08.22				CODE NO			
L K HOIST CO., LTD.							

SPECIFICATION	MAGNET CONTACT		LOAD LIMITER	SILICON RECTIFIER				Thermal Protector	HOIST MOTOR
SYMBOLS	M101, M102		-	DPM30				TP1	HM
DESCRIPTION	DMC-22	GMC-22	LKDL-60A	AC220V	AC440V	AC460V	AC480V	17AM032	3.5Kw * 4P
				DC99V	DC198V	DC207V	DC216V		
MAKER	DONG-A	LS	LK	LK				Texas Instruments	LK

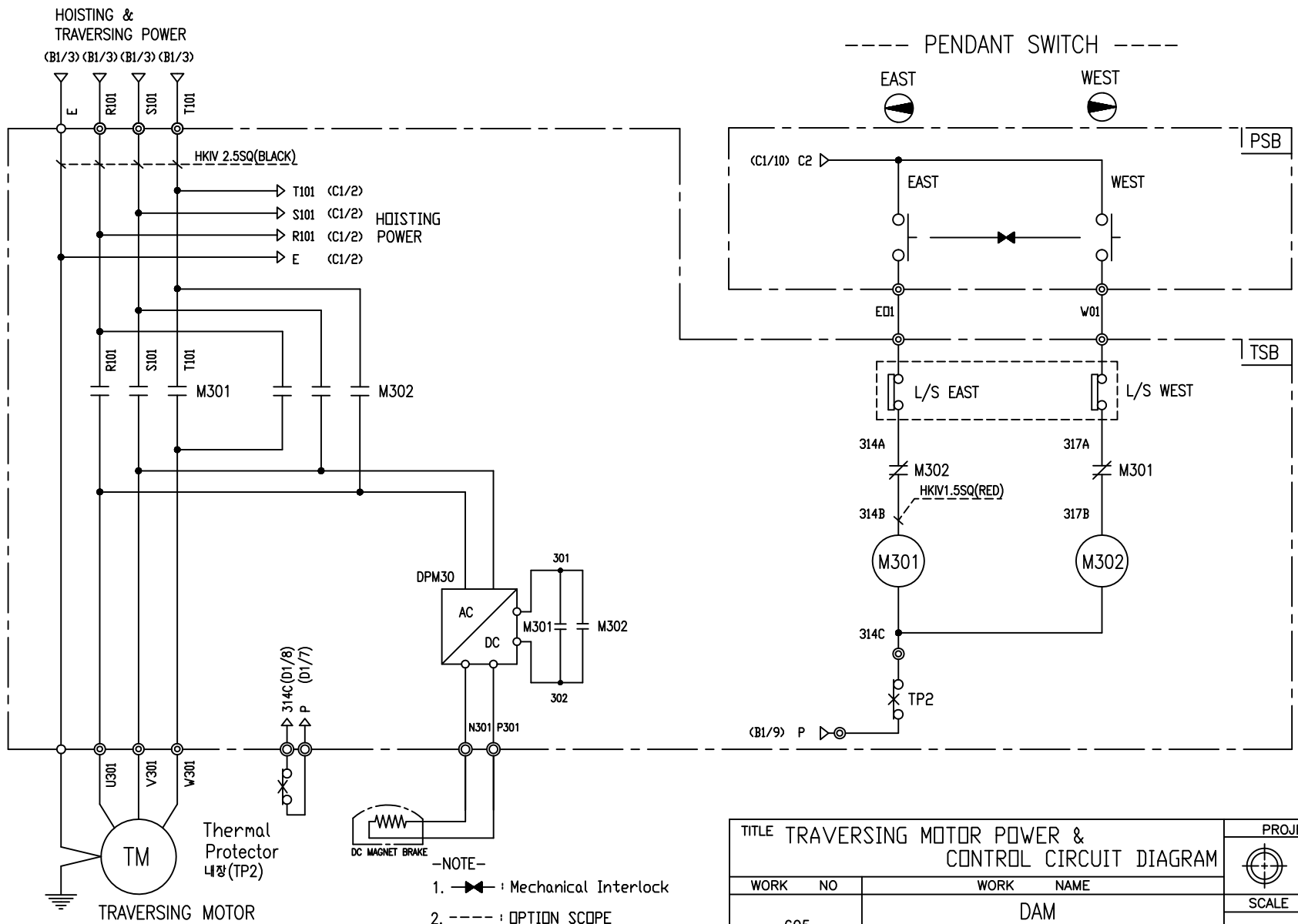

SPECIFICATION	MAGNET CONTACT	Thermal Protector	SILICON RECTIFIER	TRAVERSING MOTOR
SYMBOLS	M301, M302	TP2	DPM30	TM
DESCRIPTION	GMC12 DMC12b	17AM032	AC220V AC440V AC460V AC480V	0.75KW *4P 0.4KW *6P
			DC99V DC198V DC207V DC216V	
MAKER	LS DONGA	Texas Instruments	LK	LK

TITLE TRAVERSING MOTOR POWER & CONTROL CIRCUIT DIAGRAM						PROJECTION	
WORK NO		WORK NAME					
605		DAM				SCALE	
		220V, 440V, 460V, 480V				Q' TY	
		1/1				1	
DRAWN	CHECKED	REVIEWED	APPROVED	MODEL	DAM		
LEE.G.H				CODE NO			
2019.08.22							
L K HOIST CO., LTD.							

SCHEDULE OF TECHNICAL DATA

1. SERVICE	HOISTING
2. MANUFACTURE	LK HOIST CO. LTD
3. MOTOR MODEL NO	3.5 - 4 - 48
4. RATED POWER	3.5 KW × 4 P
5. RATED VOLTAGE AND FREQUENCY	480 V 60HZ
6. MOTOR TYPE	SQUIRREL CAGE ROTOR TYPE
7. RATING	30 MIN
8. LOCATION	IN-DOOR , OUTDOOR
9. INSULATION CLASS	B
10. DESIGN TEMPERATURE RISE (BY RESISTANCE)	80℃
11. FULL LOAD SPEED	1740 RPM
12. FULL LOAD CURRENT	7.9 A
13. STARTING CURRENT AT RATED VOLTAGE	38.5 A
14. MINIMUM STARTING VOLTAGE	432 V
15. EFFICIENCY AT 100% RATED LOAD	73.5 %
16. POWER FACTOR AT 100% RATED LOAD	73.0 %
17. STARTING TORQUE	247 %
18. TYPE OF ENCLOSURE	전폐형(IP-54)
19. TYPE OF BEARING	PL : 6205DD OPL : 6008ZZ
20. MOUNTING	VERTICAL
21. MAXIMUM AMBIENT TEMPURE	40℃
22. BEARING LUBRICATION	GREASE
23. STARTING METHOD	FULL VOLTAGE

SCHEDULE OF TECHNICAL DATA

1. SERVICE	TRAVERSING
2. MANUFACTURE	LK HOIST CO. LTD
3. MOTOR MODEL NO	0.75 - 4 - 48
4. RATED POWER	0.75 KW × 4 P
5. RATED VOLTAGE AND FREQUENCY	480 V 60HZ
6. MOTOR TYPE	SQUIRREL CAGE ROTOR TYPE
7. RATING	15 MIN
8. LOCATION	OUTDOOR
9. INSULATION CLASS	B
10. DESIGN TEMPERATURE RISE (BY RESISTANCE)	100℃
11. FULL LOAD SPEED	1670 RPM
12. FULL LOAD CURRENT	2.2 A
13. STARTING CURRENT AT RATED VOLTAGE	12.1 A
14. MINIMUM STARTING VOLTAGE	432 V
15. EFFICIENCY AT 100% RATED LOAD	65 %
16. POWER FACTOR AT 100% RATED LOAD	63 %
17. STARTING TORQUE	250 %
18. TYPE OF ENCLOSURE	전폐형
19. TYPE OF BEARING	PL : 6008DD OPL : 6207ZZ
20. MOUNTING	VERTICAL
21. MAXIMUM AMBIENT TEMPURE	40℃
22. BEARING LUBRICATION	GREASE
23. STARTING METHOD	FULL VOLTAGE

SCHEDULE OF TECHNICAL DATA

1. SERVICE	TRAVERSING
2. MANUFACTURE	LK HOIST CO. LTD
3. MOTOR MODEL NO	0.4 - 6 - 48
4. RATED POWER	0.4 KW × 6 P
5. RATED VOLTAGE AND FREQUENCY	480 V 60HZ
6. ROTOR TYPE	SQUIRREL CAGE ROTOR TYPE
7. RATING	15 MIN
8. LOCATION	OUTDOOR
9. INSULATION CLASS	B
10. DESIGN TEMPERATURE RISE (BY RESISTANCE)	100℃
11. FULL LOAD SPEED	1140 RPM
12. FULL LOAD CURRENT	1.47 A
13. STARTING CURRENT AT RATED VOLTAGE	8.1 A
14. MINIMUM STARTING VOLTAGE	432 V
15. EFFICIENCY AT 100% RATED LOAD	65 %
16. POWER FACTOR AT 100% RATED LOAD	63 %
17. STARTING TORQUE	249 %
18. TYPE OF ENCLOSURE	전폐형
19. TYPE OF BEARING	PL : 6008DD OPL : 6207ZZ
20. MOUNTING	VERTICAL
21. MAXIMUM AMBIENT TEMPERATURE	40℃
22. BEARING LUBRICATION	GREASE
23. STARTING METHOD	FULL VOLTAGE