

POWER CIRCUIT

ADDRESS NO.

TRAVELLING POWER SUPPLY SYSTEM

A1

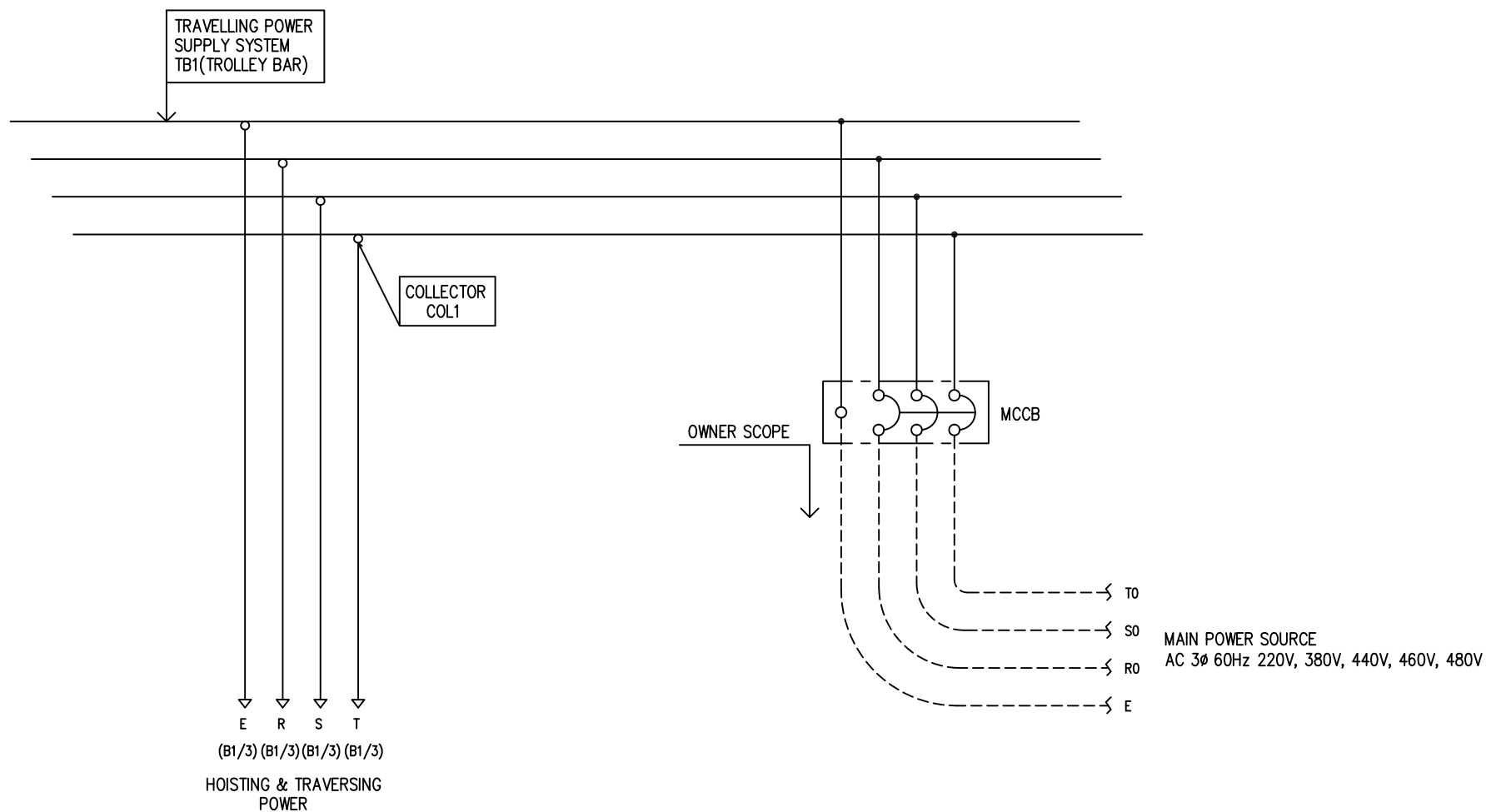

-NOTE-

1. - - - - MARKED OWNER SCOPE
2. ——— MARKED CRAIN MAKER SCOPE

TITLE				PROJECTION	
MAIN POWER CIRCUIT DIAGRAM1					
WORK NO	WORK NAME			SCALE	Q' TY
601	LTM			1/1	1
220V, 380V, 440V, 460V, 480V					
DRAWN	CHECKED	REVIEWED	APPROVED	DRAWING NO	
LEE G.H.				CODE NO	
2010.07.20					
L K HOIST CO., LTD.					

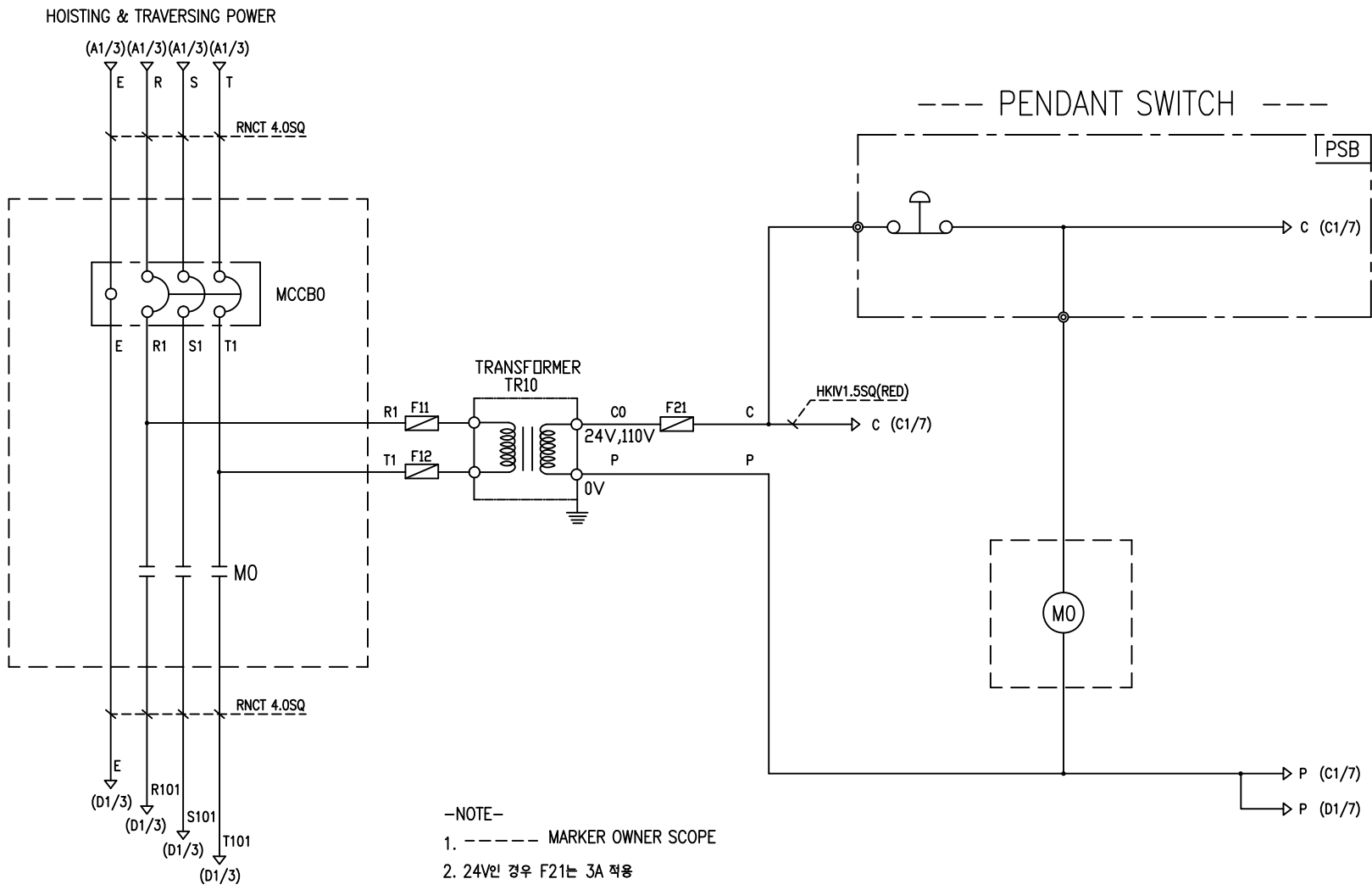

-NOTE-

1. ----- MARKER OWNER SCOPE
2. 24V인 경우 F21는 3A 적용

SPECIFICATION	NO FUSE BREAKER	MAGNET CONTACT	TRANSFORMER	FUZE	
SYMBOLS	MCCBO	MO	TR10	F11, F12, F21	
DESCRIPTION	220V	20A	30VA	1A	
	380V	15A			
	440V	10A			
	460V	10A			
	480V	10A			
MAKER	LS	LS	DONGA	LK	-

TITLE MAIN POWER & CONTROL CIRCUIT DIAGRAM						PROJECTION	
WORK NO 602		WORK NAME LTM				SCALE 1/1	Q' TY 1
DRAWN LEE.G.H	CHECKED	REVIEWED	APPROVED	DRAWING NO	LTM		CODE NO
2010.07.20							
L K HOIST CO., LTD.							

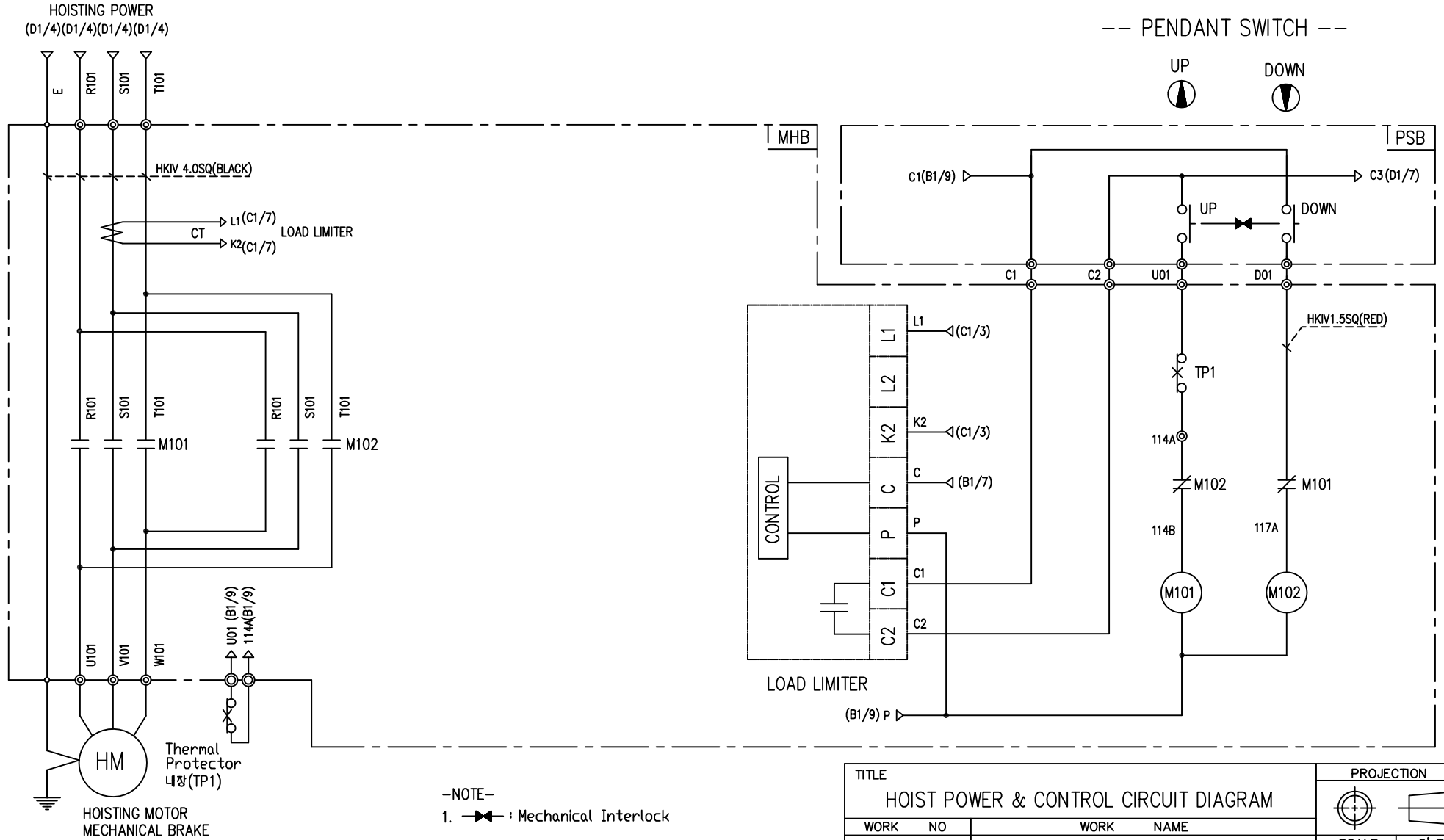

-NOTE-

1. : Mechanical Interlock

TITLE HOIST POWER & CONTROL CIRCUIT DIAGRAM						PROJECTION 	
WORK NO 603		WORK NAME LTM 220V, 380V, 440V, 460V, 480V				SCALE 1/1	Q' TY 1
DRAWN LEE.G.H 2010.07.20	CHECKED	REVIEWED	APPROVED	MODEL LTM	CODE NO		
L K HOIST CO., LTD.							

SPECIFICATION	MAGNET CONTACT		LOAD LIMITER	Thermal Protector	HOIST MOTOR	
SYMBOLS	M101, M102		-	TP1	HM	
DESCRIPTION	GMC12	DMC12	LKDL-50A	17AM032	1.8Kw * 4P	1.2Kw * 6P
MAKER	LS	DONGA	YANG-YEONG	Texas Instruments	LK	

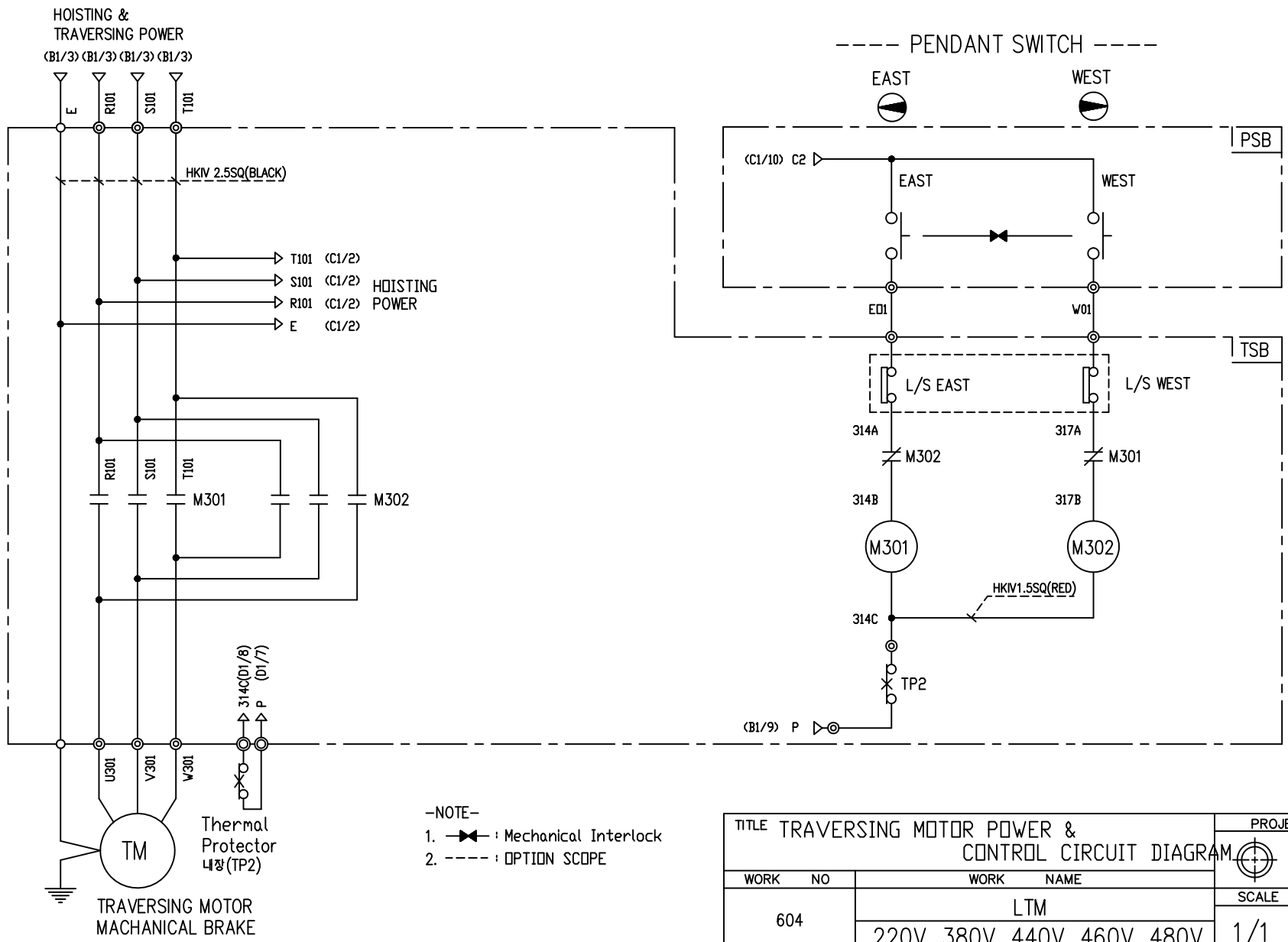

SPECIFICATION	MAGNET CONTACT	Thermal Protector	TRAVERSING MOTOR	
SYMBOLS	M301, M302	TP2	TM	
DESCRIPTION	GMC12 DMC12	17AM032	0.2KW *4P	0.3KW *2P
MAKER	LS DONGA	Texas Instruments	LK	

TITLE TRAVERSING MOTOR POWER & CONTROL CIRCUIT DIAGRAM						PROJECTION	
WORK NO		WORK NAME				SCALE	
604		LTM				1/1	
220V, 380V, 440V, 460V, 480V		Q' TY		1			
DRAWN	CHECKED	REVIEWED	APPROVED	MODEL	LTM		
LEE.G.H				CODE NO			
2010.07.20							

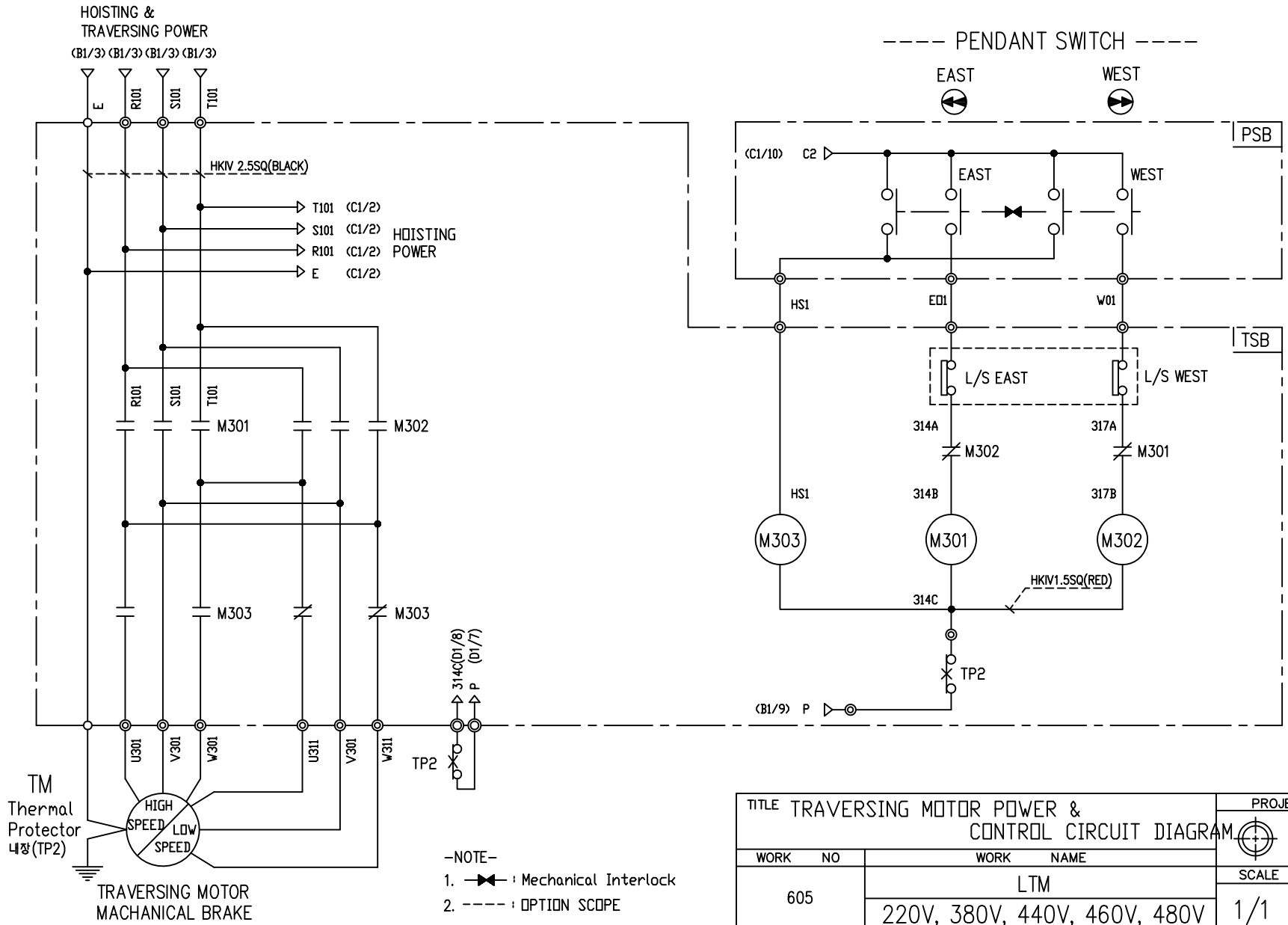

SPECIFICATION	MAGNET CONTACT	Thermal Protector	TRAVERSING MOTOR
SYMBOLS	M301, M302, M303	TP2	TM
DESCRIPTION	GMC12 DMC12	17AM032	0.3/0.15KW *2/8P
MAKER	LS DONGA	Texas Instruments	LK

TITLE TRAVERSING MOTOR POWER & CONTROL CIRCUIT DIAGRAM					PROJECTION	
WORK NO		WORK NAME			SCALE	
605		LTM			Q' TY	
		220V, 380V, 440V, 460V, 480V			1/1 1	
DRAWN	CHECKED	REVIEWED	APPROVED	MODEL	LTM	
LEE.G.H				CODE NO		
2010.07.20						
L K HOIST CO., LTD.						

SCHEDULE OF TECHNICAL DATA

1. SERVICE	HOISTING
2. MANUFACTURE	LK HOIST CO. LTD
3. MOTOR MODEL NO	1.8 - 4 - 38
4. RATED POWER	1.8 KW × 4 P
5. RATED VOLTAGE AND FREQUENCY	380 V 60HZ
6. MOTOR TYPE	SQUIRREL CAGE ROTOR TYPE
7. RATING	30 MIN
8. LOCATION	IN-DOOR , OUTDOOR
9. INSULATION CLASS	B
10. DESIGN TEMPERATURE RISE (BY RESISTANCE)	80℃
11. FULL LOAD SPEED	1720 RPM
12. FULL LOAD CURRENT	4.9 A
13. STARTING CURRENT AT RATED VOLTAGE	24.1 A
14. MINIMUM STARTING VOLTAGE	342 V
15. EFFICIENCY AT 100% RATED LOAD	69.8 %
16. POWER FACTOR AT 100% RATED LOAD	67.3 %
17. STARTING TORQUE	244 %
18. TYPE OF ENCLOSURE	전폐형
19. TYPE OF BEARING	PL : 6008DD OPL : 6207ZZ
20. MOUNTING	VERTICAL
21. MAXIMUM AMBIENT TEMPURE	40℃
22. BEARING LUBRICATION	GREASE
23. STARTING METHOD	FULL VOLTAGE

SCHEDULE OF TECHNICAL DATA

1. SERVICE	HOISTING
2. MANUFACTURE	LK HOIST CO. LTD
3. MOTOR MODEL NO	1.2 - 6 - 38
4. RATED POWER	1.2 KW × 6 P
5. RATED VOLTAGE AND FREQUENCY	380 V 60HZ
6. MOTOR TYPE	SQUIRREL CAGE ROTOR TYPE
7. RATING	30 MIN
8. LOCATION	IN-DOOR , OUTDOOR
9. INSULATION CLASS	B
10. DESIGN TEMPERATURE RISE (BY RESISTANCE)	80℃
11. FULL LOAD SPEED	1150 RPM
12. FULL LOAD CURRENT	5.2 A
13. STARTING CURRENT AT RATED VOLTAGE	23.4 A
14. MINIMUM STARTING VOLTAGE	347 V
15. EFFICIENCY AT 100% RATED LOAD	68.5 %
16. POWER FACTOR AT 100% RATED LOAD	64 %
17. STARTING TORQUE	244 %
18. TYPE OF ENCLOSURE	전폐형
19. TYPE OF BEARING	PL : 6008DD OPL : 6207ZZ
20. MOUNTING	VERTICAL
21. MAXIMUM AMBIENT TEMPURE	40℃
22. BEARING LUBRICATION	GREASE
23. STARTING METHOD	FULL VOLTAGE

SCHEDULE OF TECHNICAL DATA

1. SERVICE	TRAVERSING
2. MANUFACTURE	LK HOIST CO. LTD
3. MOTOR MODEL NO	0.3 - 2 - 38
4. RATED POWER	0.3 KW × 2 P
5. RATED VOLTAGE AND FREQUENCY	380 V 60HZ
6. MOTOR TYPE	SQUIRREL CAGE ROTOR TYPE
7. RATING	15 MIN
8. LOCATION	IN-DOOR , OUTDOOR
9. INSULATION CLASS	B
10. DESIGN TEMPERATURE RISE (BY RESISTANCE)	100℃
11. FULL LOAD SPEED	3440 RPM
12. FULL LOAD CURRENT	1.5 A
13. STARTING CURRENT AT RATED VOLTAGE	7.5 A
14. MINIMUM STARTING VOLTAGE	342 V
15. EFFICIENCY AT 100% RATED LOAD	56.3 %
16. POWER FACTOR AT 100% RATED LOAD	55.9 %
17. STARTING TORQUE	232 %
18. TYPE OF ENCLOSURE	전폐형
19. TYPE OF BEARING	PL : 6008DD OPL : 6207ZZ
20. MOUNTING	VERTICAL
21. MAXIMUM AMBIENT TEMPURE	40℃
22. BEARING LUBRICATION	GREASE
23. STARTING METHOD	FULL VOLTAGE

SCHEDULE OF TECHNICAL DATA

1. SERVICE	TRAVERSING
2. MANUFACTURE	LK HOIST CO. LTD
3. MOTOR MODEL NO	0.2 - 4 - 38
4. RATED POWER	0.2 KW × 4 P
5. RATED VOLTAGE AND FREQUENCY	380 V 60HZ
6. MOTOR TYPE	SQUIRREL CAGE ROTOR TYPE
7. RATING	15 MIN
8. LOCATION	IN-DOOR , OUTDOOR
9. INSULATION CLASS	B
10. DESIGN TEMPERATURE RISE (BY RESISTANCE)	100℃
11. FULL LOAD SPEED	1690 RPM
12. FULL LOAD CURRENT	1.2 A
13. STARTING CURRENT AT RATED VOLTAGE	6.0 A
14. MINIMUM STARTING VOLTAGE	343 V
15. EFFICIENCY AT 100% RATED LOAD	51.3 %
16. POWER FACTOR AT 100% RATED LOAD	49.4 %
17. STARTING TORQUE	232 %
18. TYPE OF ENCLOSURE	전폐형
19. TYPE OF BEARING	PL : 6008DD OPL : 6207ZZ
20. MOUNTING	VERTICAL
21. MAXIMUM AMBIENT TEMPURE	40℃
22. BEARING LUBRICATION	GREASE
23. STARTING METHOD	FULL VOLTAGE

SCHEDULE OF TECHNICAL DATA

1. SERVICE	TRAVERSING
2. MANUFACTURE	LK HOIST CO. LTD
3. MOTOR MODEL NO	0.3/0.15 - 2/8 - 38
4. RATED POWER	0.3/0.15 KW × 2/8 P
5. RATED VOLTAGE AND FREQUENCY	380 V 60HZ
6. MOTOR TYPE	SQUIRREL CAGE ROTOR TYPE
7. RATING	15 MIN
8. LOCATION	IN-DOOR , OUTDOOR
9. INSULATION CLASS	B
10. DESIGN TEMPERATURE RISE (BY RESISTANCE)	100℃
11. FULL LOAD SPEED	3440 / 840 RPM
12. FULL LOAD CURRENT	1.5 / 1.3 A
13. STARTING CURRENT AT RATED VOLTAGE	7.5 / 6.7 A
14. MINIMUM STARTING VOLTAGE	343 V
15. EFFICIENCY AT 100% RATED LOAD	56.3 / 42.5 %
16. POWER FACTOR AT 100% RATED LOAD	54.0 / 41.2 %
17. STARTING TORQUE	232/ 234 %
18. TYPE OF ENCLOSURE	전폐형
19. TYPE OF BEARING	PL : 6008DD OPL : 6207ZZ
20. MOUNTING	VERTICAL
21. MAXIMUM AMBIENT TEMPURE	40℃
22. BEARING LUBRICATION	GREASE
23. STARTING METHOD	FULL VOLTAGE