

ON 9MG

L K HOIST

NO	DESCRIPTION	SIZE	MAT' L	Q' TY	WT (kg)	REMARKS

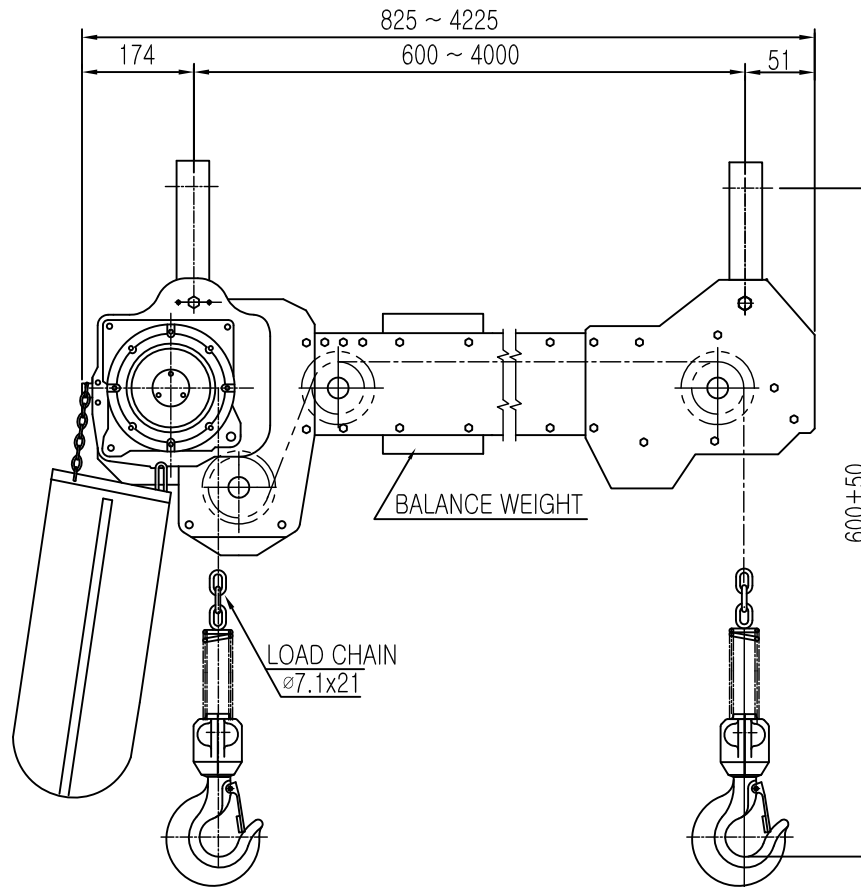
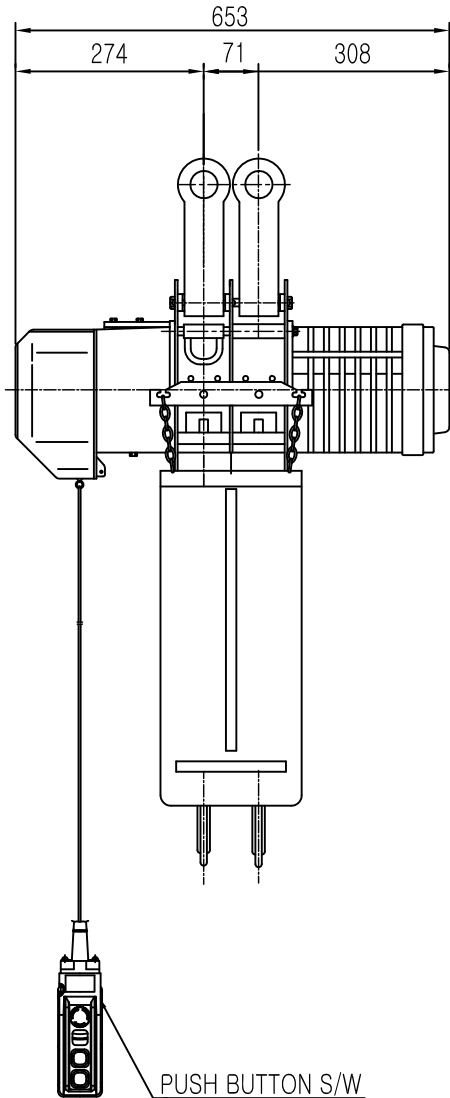

SPECIFICATION		
RATED	1.0	TON
TESTING LOAD	1.25	TON
LIFTING HEIGHT	50	M
HOISTING	SPEED	8.2 M/MIN
	MOTOR	1.8 KW x 4P
TRAVERSING	SPEED	-
	MOTOR	-
POWER SUPPLY	AC220,380,440,460,480 V x 3ø x 60 Hz	
OPERATING METHOD	P.B type ON . FL	
LOAD CHAIN	ø7.1 x 21 (1FALL)	
WIEGHT	286 KG	

TITLE					PROJECTION	
DHDA-1S ELECTRIC CHAIN HOIST						
WORK NO	WORK NAME				SCALE	Q' TY
	CONNECTOR TYPE				N S	1
DRAWN	CHECKED	REVIEWED	APPROVED	DRAWING NO		
김 창 기				CORD NO		
2010.08.01						

REV.NO	DATE	REVISION	DESCRIPTION	DRAWN	CHECKED	APPROVED



L K HOIST CO., LTD.

ON 9WD

L K HOIST

NO	DESCRIPTION	SIZE	MAT' L	Q' TY	WT (kg)	REMARKS

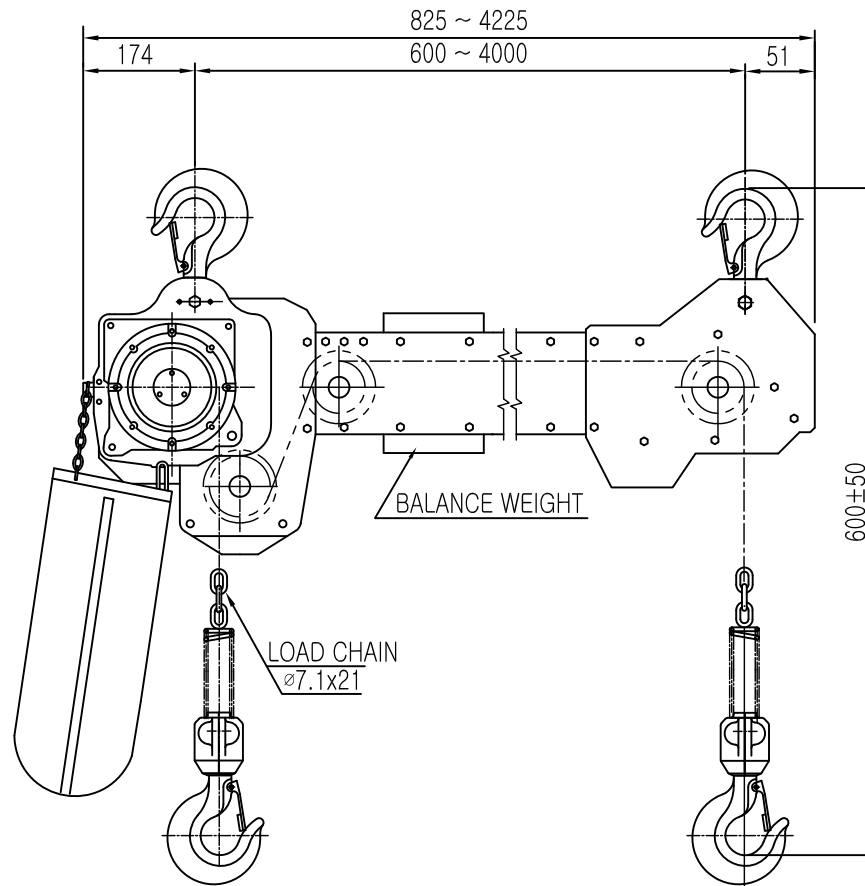
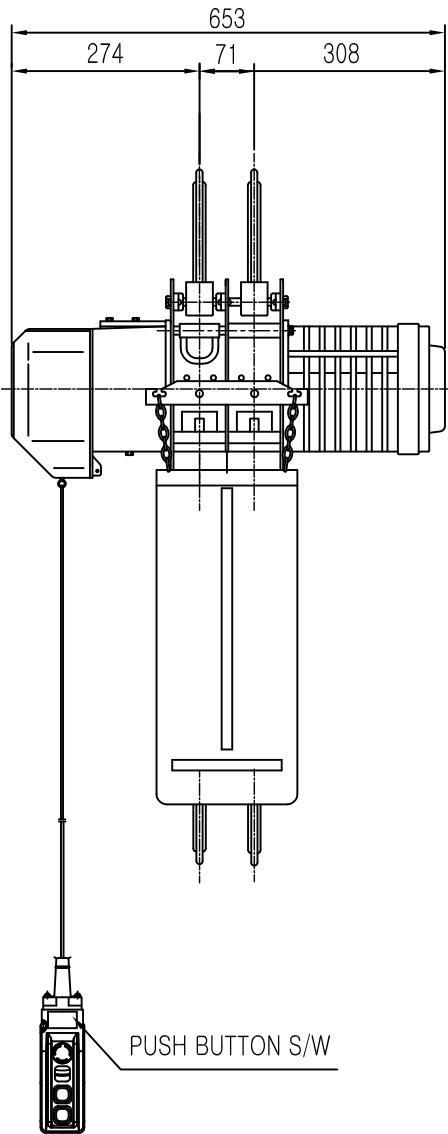

SPECIFICATION	
RATED	1.0 TON
TESTING LOAD	1.25 TON
LIFTING HEIGHT	50 M
HOISTING	SPEED 8.2 M/MIN
	MOTOR 1.8 KW x 4P
TRAVERSING	SPEED -
	MOTOR -
POWER SUPPLY	AC220,380,440,460,480 V x 3ø x 60 Hz
OPERATING METHOD	P.B type ON . FL
LOAD CHAIN	ø7.1 x 21 (1FALL)
WIEGHT	286 KG

NOTE)

- 1) 점검 설비를 갖출것.
- 2) 인허가 서류를 완성검사시 제출할것.

TITLE					PROJECTION	
DHDA-1S ELECTRIC CHAIN HOIST						
WORK NO	WORK NAME				SCALE	Q' TY
	HOOK TYPE				N S	1
DRAWN	CHECKED	REVIEWED	APPROVED	DRAWING NO		
김 창 기				CORD NO		
2010.08.01						
L K HOIST CO., LTD.						

REV.NO	DATE	REVISION	DESCRIPTION	DRAWN	CHECKED	APPROVED

ON ㉠

L K HOIST

NO	DESCRIPTION	SIZE	MAT' L	Q' TY	WT (kg)	REMARKS

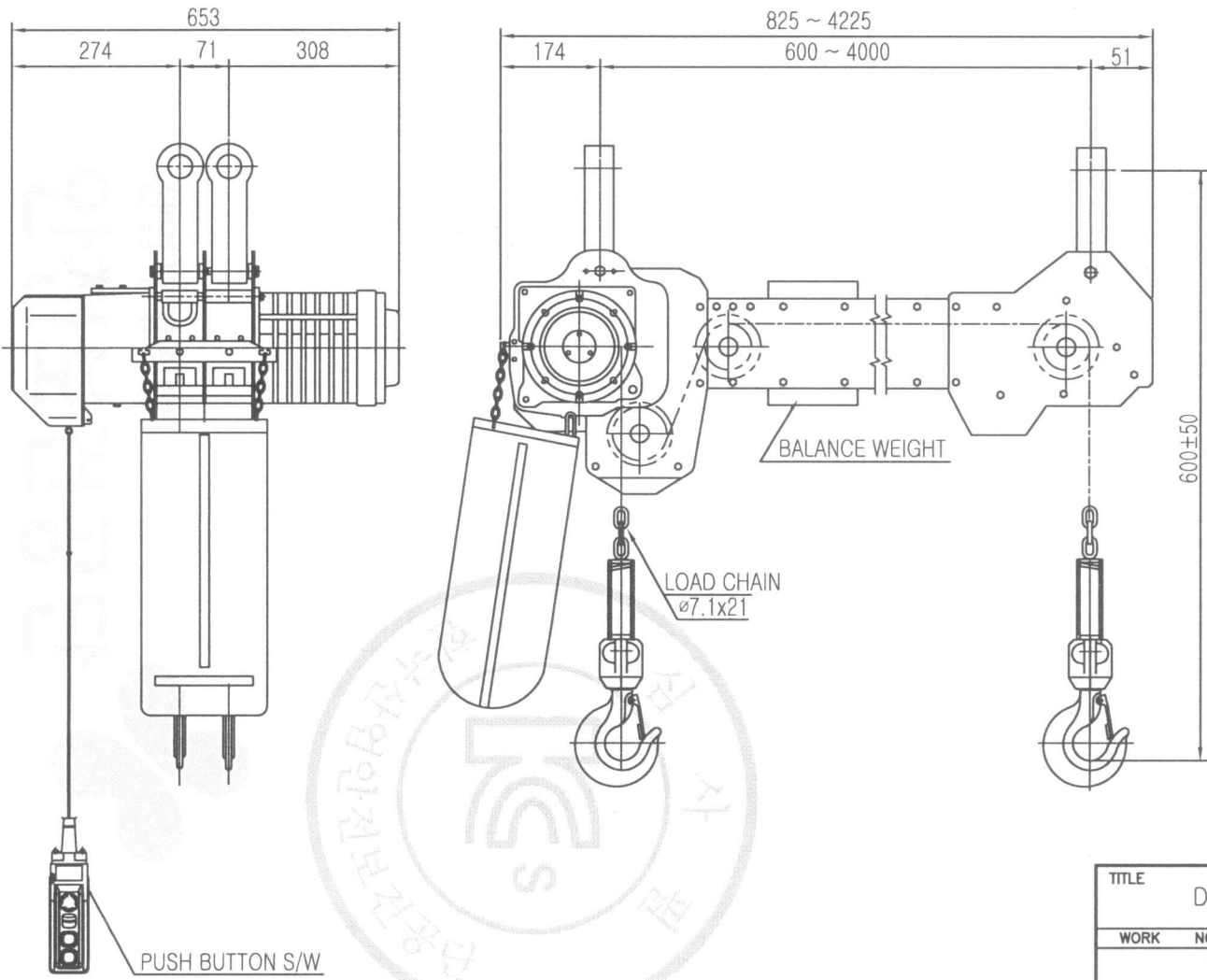

SPECIFICATION	
RATED	1.0 TON
TESTING LOAD	1.25 TON
LIFTING HEIGHT	50 M
HOISTING	SPEED 8.2 M/MIN
	MOTOR 1.8 KW x 4P
TRAVERSING	SPEED -
	MOTOR -
POWER SUPPLY	AC220,380,440,460,480 V x 3ø x 60 Hz
OPERATING METHOD	P.B type ON . FL
LOAD CHAIN	ø7.1 x 21 (1FALL)
WIEGHT	286 KG

별첨복제 및 배포금지

TITLE		PROJECTION	
DHDA-1S ELECTRIC CHAIN HOIST			
WORK NO	WORK NAME	SCALE	Q' TY
	CONNECTOR TYPE	N S	1
DRAWN	CHECKED	REVIEWED	APPROVED
김창기			
2010.08.01			
DRAWING NO		CORD NO	

REV.NO	DATE	REVISION	DESCRIPTION	DRAWN	CHECKED	APPROVED

LK L K HOIST CO., LTD.

L K HOIST

ON 5MD

NO	DESCRIPTION	SIZE	MAT' L	Q' TY	WT (kg)	REMARKS

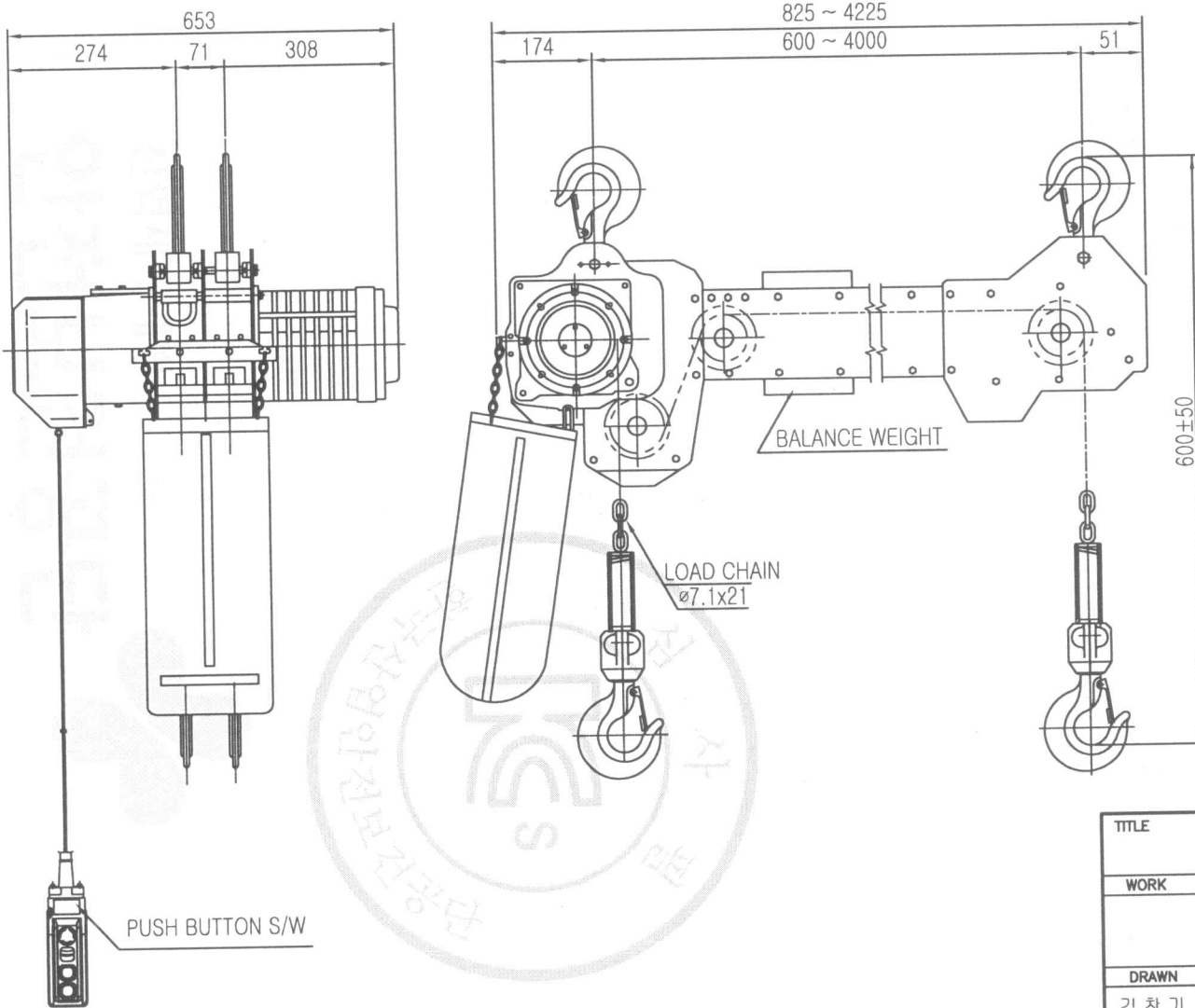

SPECIFICATION	
RATED	1.0 TON
TESTING LOAD	1.25 TON
LIFTING HEIGHT	50 M
HOISTING	SPEED 8.2 M/MIN
	MOTOR 1.8 KW x 4P
TRAVERSING	SPEED -
	MOTOR -
POWER SUPPLY	AC220,380,440,460,480 V x 3ø x 60 Hz
OPERATING METHOD	P.B type ON . FL
LOAD CHAIN	ø7.1 x 21 (1FALL)
WIEGHT	286 KG

NOTE)

- 1) 점검 설비를 갖출것.
- 2) 인허가 서류를 완성검사시 제출할것.

물범북제 및 배포금지

TITLE					PROJECTION	
DHDA-1S ELECTRIC CHAIN HOIST						
WORK NO	WORK NAME			SCALE	Q' TY	
	HOOK TYPE			N S	1	
DRAWN	CHECKED	REVIEWED	APPROVED	DRAWING NO		
김창기						
2010.08.01				CORD NO		
L K HOIST CO., LTD.						

REV.NO	DATE	REVISION	DESCRIPTION	DRAWN	CHECKED	APPROVED