

POWER CIRCUIT  
TRAVELLING POWER SUPPLY SYSTEM

ADDRESS NO.  
A1

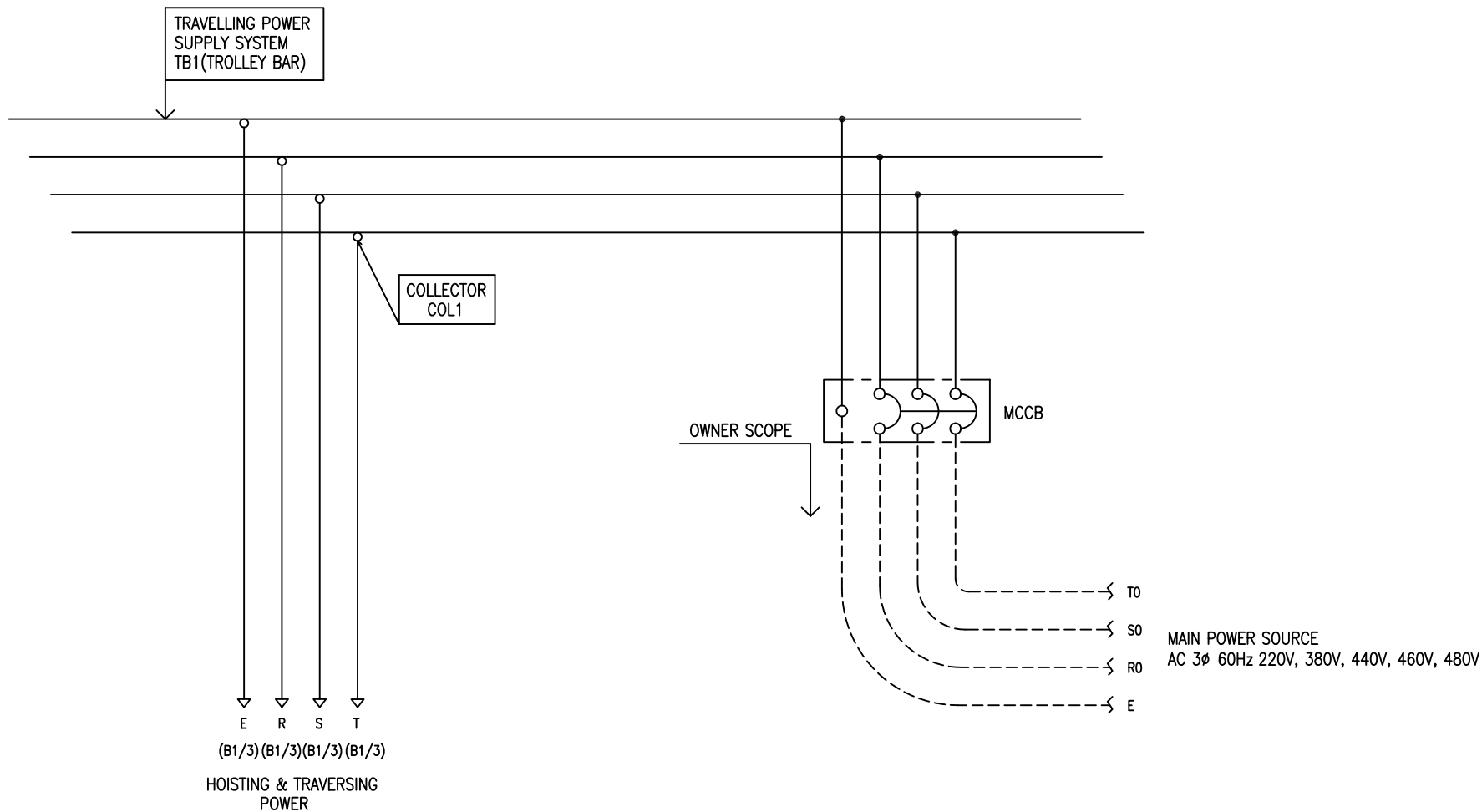

-NOTE-

- 1. - - - - MARKED OWNER SCOPE
- 2. ——— MARKED CRAIN MAKER SCOPE

TITLE MAIN POWER CIRCUIT DIAGRAM1						PROJECTION 	
WORK NO 601		WORK NAME DAM				SCALE 1/1	Q' TY 1
DRAWN LEE G.H. 2020.02.01		CHECKED	REVIEWED	APPROVED	DRAWING NO DAM	CODE NO	
L K HOIST CO., LTD.							

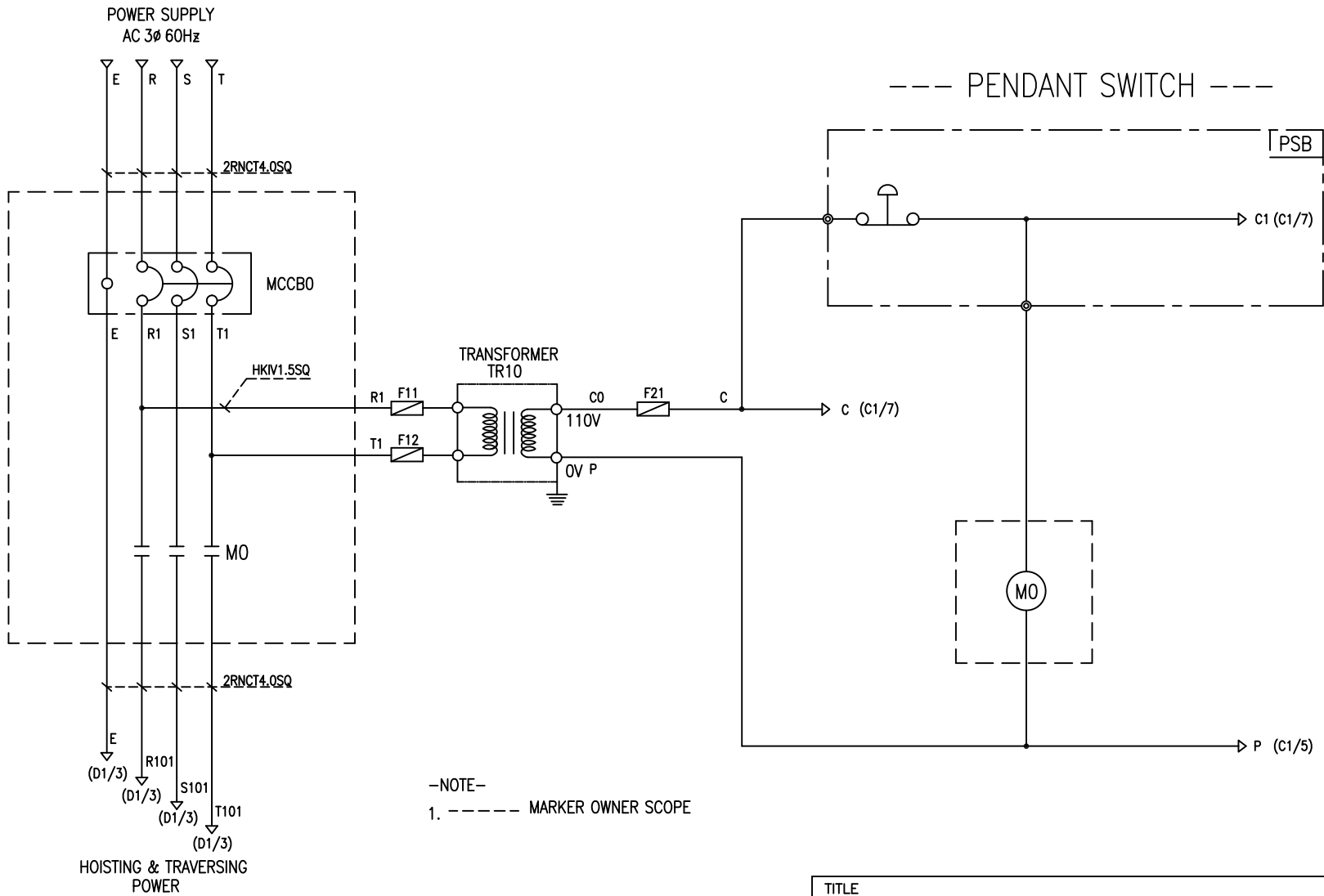

-NOTE-  
1. ----- MARKER OWNER SCOPE

SPECIFICATION	NO FUSE BREAKER	MAGNET CONTACT	TRANSFORMER	FUZE
SYMBOLS	MCCBO	MO	TR10	F11, F12, F21
DESCRIPTION	220V	30A	30VA	1A
	380V	15A		
	440V	15A		
	460V	15A		
	480V	15A		
MAKER	LS	LS	DONGA	LK

TITLE MAIN POWER & CONTROL CIRCUIT DIAGRAM						PROJECTION 	
WORK NO 602		WORK NAME DAM				SCALE 1/1	
220V, 380V, 440V, 460V, 480V		Q' TY 1					
DRAWN LEE.G.H	CHECKED	REVIEWED	APPROVED	MODEL	DAM		
2020.02.01				CODE NO			
L K HOIST CO., LTD.							

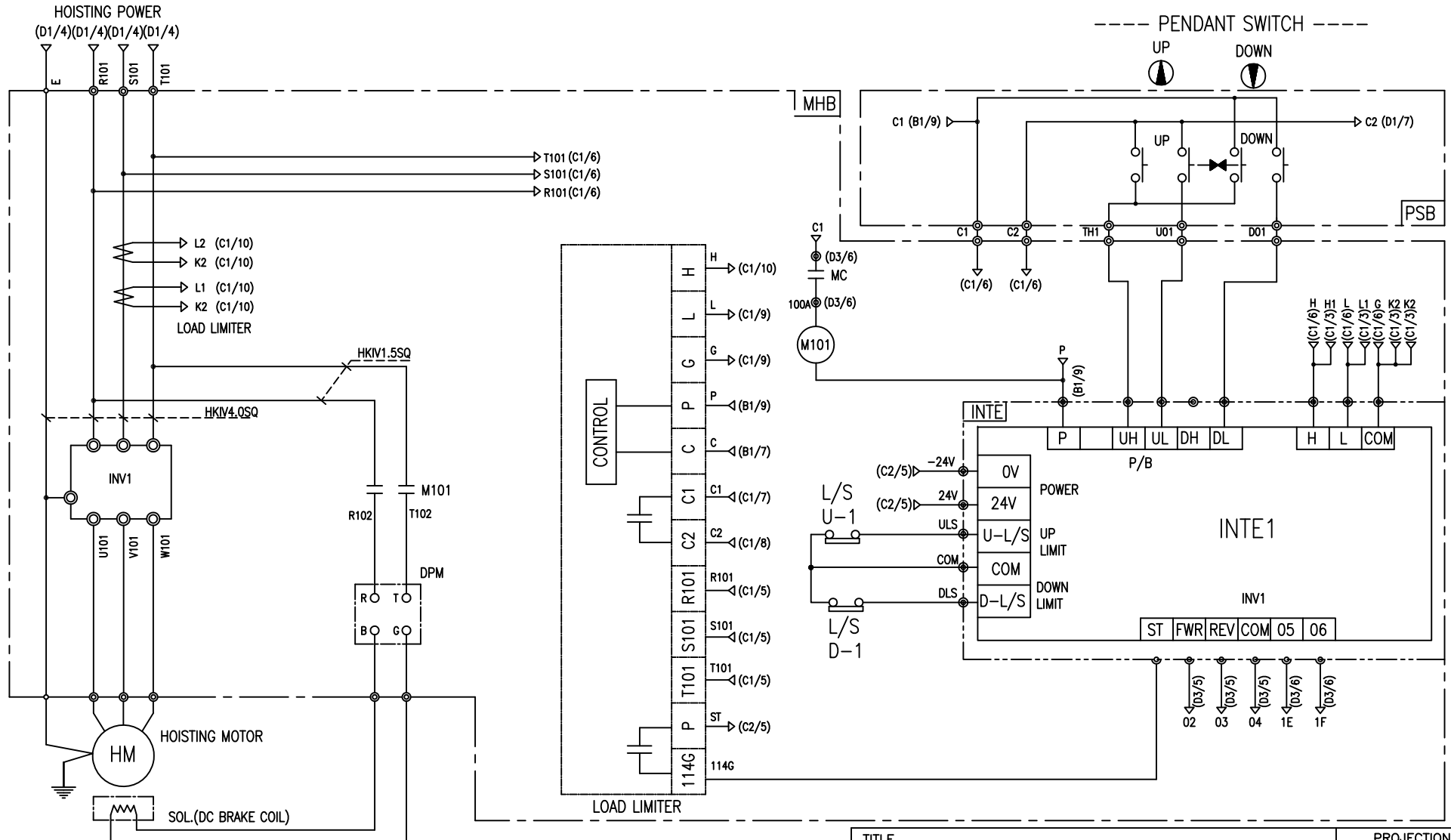

-NOTE-  
 1. —>|< : Mechanical Interlock

TITLE HOIST POWER & CONTROL CIRCUIT DIAGRAM						PROJECTION 	
WORK NO 603		WORK NAME DAM				SCALE 1/1	Q' TY 1
220V, 380V, 440V, 460V, 480V							
DRAWN LEE.G.H	CHECKED	REVIEWED	APPROVED	MODEL DAM	CODE NO		
2020.02.01							

SPECIFICATION	RELAY	LOAD LIMITER	SILICON RECTIFIER				HOIST MOTOR	
SYMBOLS	M101	-	DPM				HM	
DESCRIPTION	2A2B	LKDL-80	AC220V DC99V	AC380V DC171V	AC440V DC198V	AC460V DC207V	AC480V DC216V	1.8Kw * 4P
MAKER	DAE-IL	LK	SAMMUSCO				LK	

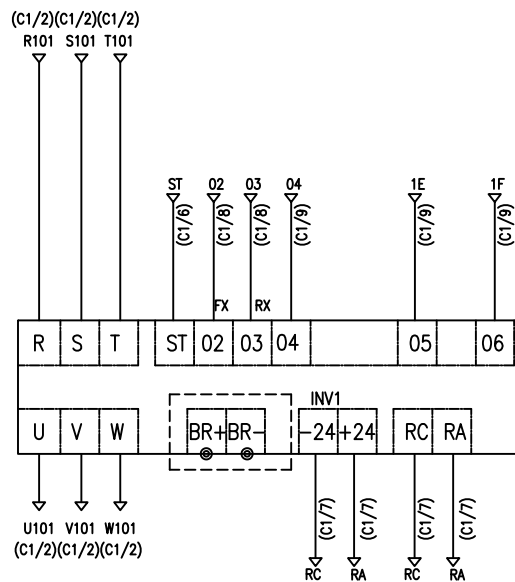

-NOTE-

1. ----- : OPTION SCOPE

SPECIFICATION	INVERTER	BRAKING RESISTOR	
SYMBOLS	INV1	BR	
DESCRIPTION	4.0KW	200V	600W 33 OHM
		400V	600W 130 OHM
MAKER	LS	-	

TITLE						(D1/6) PROJECTION	
INVERTER CONTROL CIRCUIT DIAGRAM							
WORK NO	WORK NAME					SCALE	Q' TY
604	HOISTING					1/1	1
220V, 380V, 440V, 460V, 480V							
DRAWN	CHECKED	REVIEWED	APPROVED	MODEL	DAM		
LEE.G.H							
2020.02.01				CODE NO			

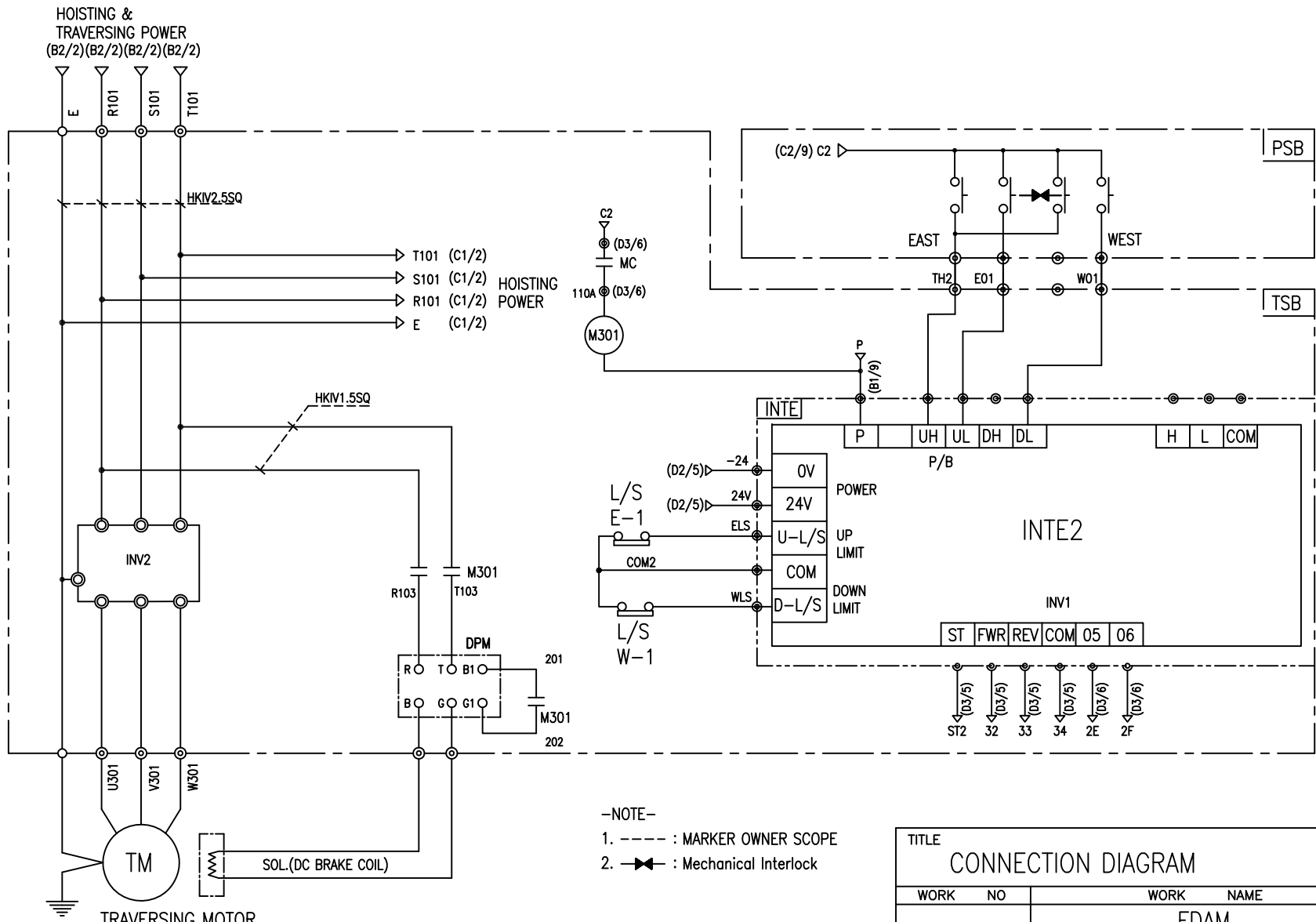

-NOTE-  
 1. - - - - : MARKER OWNER SCOPE  
 2. —|> : Mechanical Interlock

TITLE <b>CONNECTION DIAGRAM</b>						PROJECTION 	
WORK NO 605		WORK NAME FDAM				SCALE Q' TY	
220V, 380V, 440V, 460V, 480V							
DRAWN LEE.G.H	CHECKED	REVIEWED	APPROVED	MODEL FDAM	CODE NO CODE_NO		
2020.02.01							
<b>L K HOIST CO., LTD.</b>							

SPECIFICATION	MAGNET CONTACT	SILICON RECTIFIER					HOIST MOTOR
SYMBOLS	M301	DPM					TM
DESCRIPTION	DMC12b	AC220V	AC380V	AC440V	AC460V	AC480V	0.75Kw * 4P
		DC99V	DC171V	DC198V	DC207V	DC216V	0.4Kw * 6P
MAKER	DONG-A	YANG-YEUNG					LK

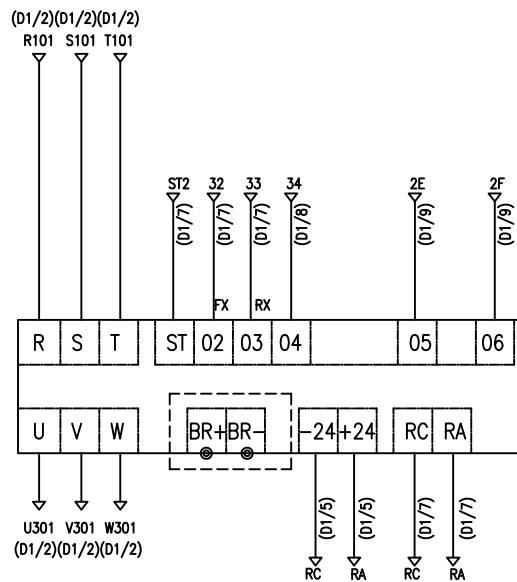

-NOTE-

1. ----- : OPTION SCOPE

SPECIFICATION	INVERTER	BRAKING RESISTOR	
SYMBOLS	INV2	BR	
DESCRIPTION	0.75KW	200V	150W 150 OHM
		400V	150W 600 OHM
MAKER	LS	-	

TITLE						(D1/6) PROJECTION	
INVERTER CONTROL CIRCUIT DIAGRAM							
WORK NO	WORK NAME					SCALE	Q' TY
606	TRAVERSING					1/1	1
220V, 380V, 440V, 460V, 480V							
DRAWN	CHECKED	REVIEWED	APPROVED	MODEL	DAM		
LEE.G.H							
2020.02.01				CODE NO			

## SCHEDULE OF TECHNICAL DATA

1. SERVICE	HOISTING
2. MANUFACTURE	LK HOIST CO. LTD
3. MOTOR MODEL NO	1.8 - 4 - 44
4. RATED POWER	1.8 KW × 4 P
5. RATED VOLTAGE AND FREQUENCY	440 V      60HZ
6. MOTOR TYPE	SQUIRREL CAGE ROTOR TYPE
7. RATING	30 MIN
8. LOCATION	IN-DOOR , OUTDOOR
9. INSULATION CLASS	B
10. DESIGN TEMPERATURE RISE (BY RESISTANCE)	80℃
11. FULL LOAD SPEED	1740 RPM
12. FULL LOAD CURRENT	4.7 A
13. STARTING CURRENT AT RATED VOLTAGE	23.5 A
14. MINIMUM STARTING VOLTAGE	396 V
15. EFFICIENCY AT 100% RATED LOAD	72.0 %
16. POWER FACTOR AT 100% RATED LOAD	69.8 %
17. STARTING TORQUE	245 %
18. TYPE OF ENCLOSURE	전폐형
19. TYPE OF BEARING	PL : 6008DD    OPL : 6207ZZ
20. MOUNTING	VERTICAL
21. MAXIMUM AMBIENT TEMPURE	40℃
22. BEARING LUBRICATION	GREASE
23. STARTING METHOD	FULL VOLTAGE

## SCHEDULE OF TECHNICAL DATA

1. SERVICE	TRAVERSING
2. MANUFACTURE	LK HOIST CO. LTD
3. MOTOR MODEL NO	0.75 - 4 - 44
4. RATED POWER	0.75 KW × 4 P
5. RATED VOLTAGE AND FREQUENCY	440 V      60HZ
6. MOTOR TYPE	SQUIRREL CAGE ROTOR TYPE
7. RATING	15 MIN
8. LOCATION	OUTDOOR
9. INSULATION CLASS	B
10. DESIGN TEMPERATURE RISE (BY RESISTANCE)	100℃
11. FULL LOAD SPEED	1710 RPM
12. FULL LOAD CURRENT	2.4 A
13. STARTING CURRENT AT RATED VOLTAGE	13.2 A
14. MINIMUM STARTING VOLTAGE	396 V
15. EFFICIENCY AT 100% RATED LOAD	65 %
16. POWER FACTOR AT 100% RATED LOAD	63 %
17. STARTING TORQUE	249 %
18. TYPE OF ENCLOSURE	전폐형
19. TYPE OF BEARING	PL : 6008DD    OPL : 6207ZZ
20. MOUNTING	VERTICAL
21. MAXIMUM AMBIENT TEMPURE	40℃
22. BEARING LUBRICATION	GREASE
23. STARTING METHOD	FULL VOLTAGE

## SCHEDULE OF TECHNICAL DATA

1. SERVICE	TRAVERSING
2. MANUFACTURE	LK HOIST CO. LTD
3. MOTOR MODEL NO	0.4 - 6 - 44
4. RATED POWER	0.4 KW × 6 P
5. RATED VOLTAGE AND FREQUENCY	440 V      60HZ
6. ROTOR TYPE	SQUIRREL CAGE ROTOR TYPE
7. RATING	15 MIN
8. LOCATION	OUTDOOR
9. INSULATION CLASS	B
10. DESIGN TEMPERATURE RISE (BY RESISTANCE)	100℃
11. FULL LOAD SPEED	1140 RPM
12. FULL LOAD CURRENT	1.6 A
13. STARTING CURRENT AT RATED VOLTAGE	8.8 A
14. MINIMUM STARTING VOLTAGE	396 V
15. EFFICIENCY AT 100% RATED LOAD	65 %
16. POWER FACTOR AT 100% RATED LOAD	63 %
17. STARTING TORQUE	250 %
18. TYPE OF ENCLOSURE	전폐형
19. TYPE OF BEARING	PL : 6008DD    OPL : 6207ZZ
20. MOUNTING	VERTICAL
21. MAXIMUM AMBIENT TEMPERATURE	40℃
22. BEARING LUBRICATION	GREASE
23. STARTING METHOD	FULL VOLTAGE